

Installation Instructions

1100/G2-1100 Handrails

Please read all instructions before installing handrail.

Important

1. Acclimate materials 24 hrs before installation. Maintain temperature controlled environment after installation
2. Install in accordance with manufacturer's installation instructions. Failure to do so will void the warranty.

Installation tips

1. Cut covers up to 1/16" (1.6mm) longer to ensure a tight fit.
2. Lubricate blades when cutting aluminum to reduce burrs.

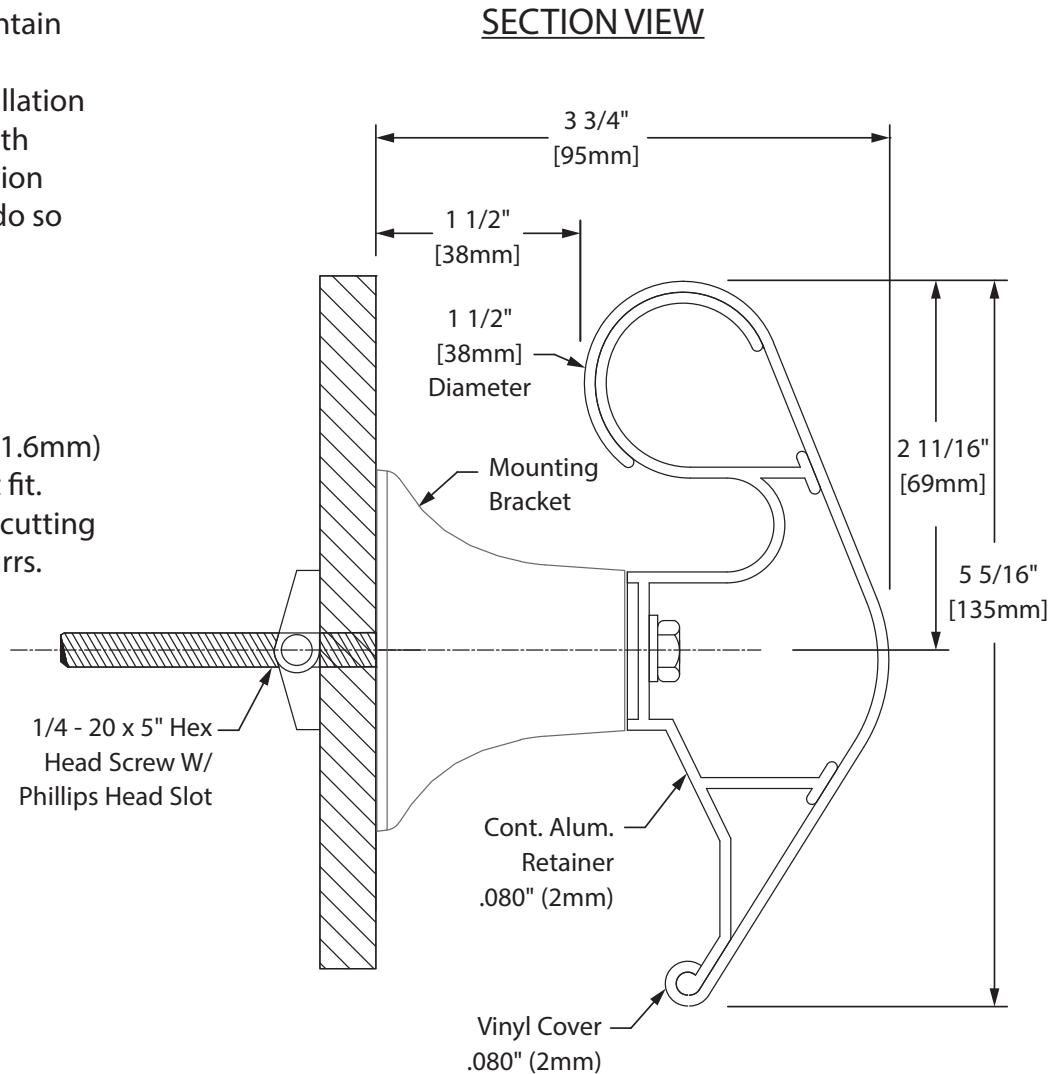

Recommended tools

Safety Glasses, Tape Measure, 3/8" socket for machine screw hex bolt, 7/16" socket for wood screw hex bolt Level, Power Drill, Drill Bits - 1/4" masonry (concrete/concrete block), Power Miter Saw, 10" Blade with 60-80 Carbide Tipped Teeth

IPC.329/REV.10

IPC® Door + Wall Protection

inpro.com • 800.222.5556 • 262.679.9010

World Headquarters S80 W18766 Apollo Drive, Muskego, WI 53150 USA

Installation Hotline: 866.394.6776

inpro®

Installation Instructions

Please read all instructions before installing handrail.

1100/G2-1100 Handrails

Components and fasteners

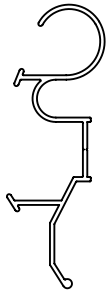

1100A
CONTINUOUS
ALUMINUM RETAINER

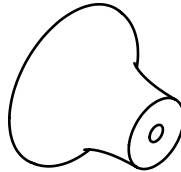

1001
MOUNTING
BRACKET

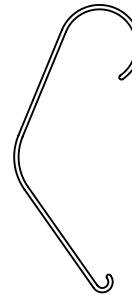

1100V
VINYL
COVER

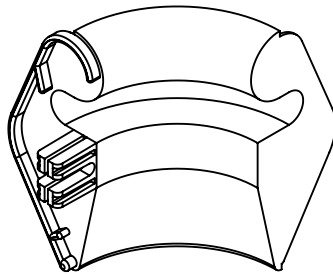

1102
LEFT RETURN

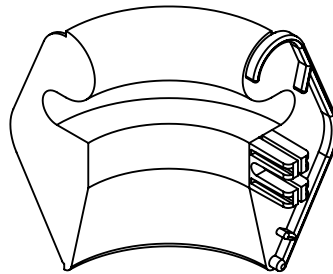

1103
RIGHT RETURN

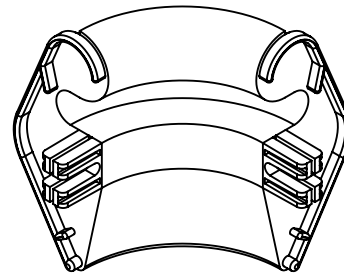

1104
OUTSIDE CORNER



804-910-SPL
SPLICE



1/4"
LOCK WASHER
SPRING REGULAR



1/4" - 20
FLANGED SCREW
HEX NUT



1/4" - 20
HEX WASHER
SCREW

Wall Condition	Specified Fasteners	Inpro Part #
Steel Stud/Gypsum Wall	1/4-20 x 5" Phillips hex head Bolt with toggle wing and lock washer	HWK-1001D
Concrete/Concrete Block	1/4-20 x 5" Phillips hex head bolt with lead anchor and lock washer	HWK-1001C
Wood Stud/Gypsum Wall	1/4" x 5" Hex Head Wood Screw and lock washer	HWK-1001W
16 gauge steel Backer/Gypsum wall	#14 X 4" Indented hex washer, zink-plated TEK SCREW	HW69
Steel Stud or Metal Backer/Drywall (OSHDP)	1/4-20 x 5" Phillips hex head Bolt with lock washer and 1/4" Hilti Toggler	HWK-1001OD
Concrete/Concrete Block (OSHDP)	1/4" x 4" Torx Hex Washer Head Screw (Hilti Kwik-Con II) and lock washer	HWK-1001OC
Wood Stud or Wood Backer/Gypsum Wall (OSHDP)	1/4" x 5" Hex Head Wood Screw and lock washer	HWK-1001OW

IPC® Door + Wall Protection

inpro.com • 800.222.5556 • 262.679.9010

World Headquarters S80 W18766 Apollo Drive, Muskego, WI 53150 USA

Installation Hotline: 866.394.6776

inpro®

Installation Instructions

1100/G2-1100 Handrails

Please read all instructions before installing handrail.

Layout view

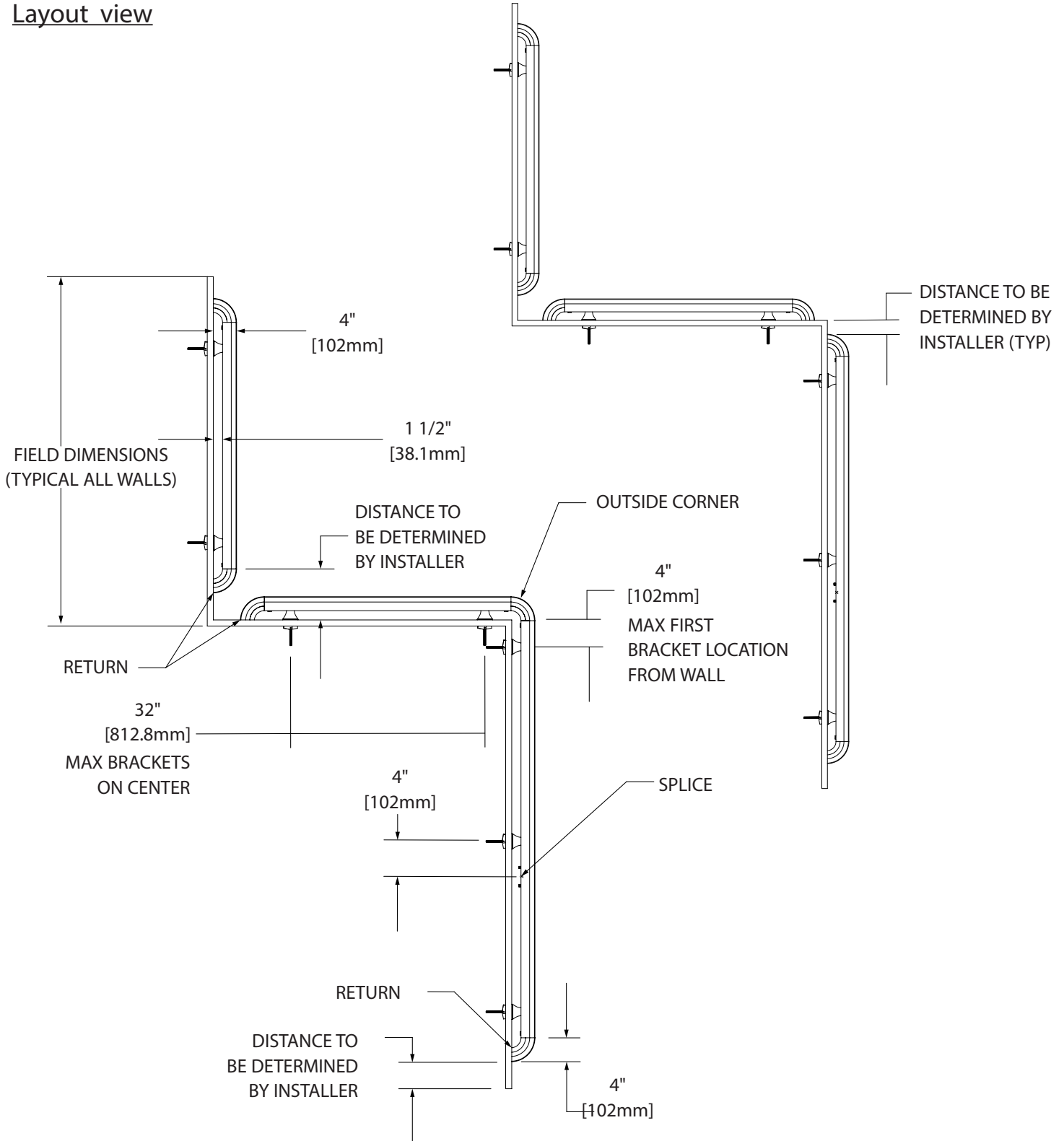

IPC® Door + Wall Protection

inpro.com • 800.222.5556 • 262.679.9010

World Headquarters S80 W18766 Apollo Drive, Muskego, WI 53150 USA

Installation Hotline: 866.394.6776

inpro®

Installation Instructions

1100/G2-1100 Handrails

Please read all instructions
before installing handrail.

Exploded view assembly

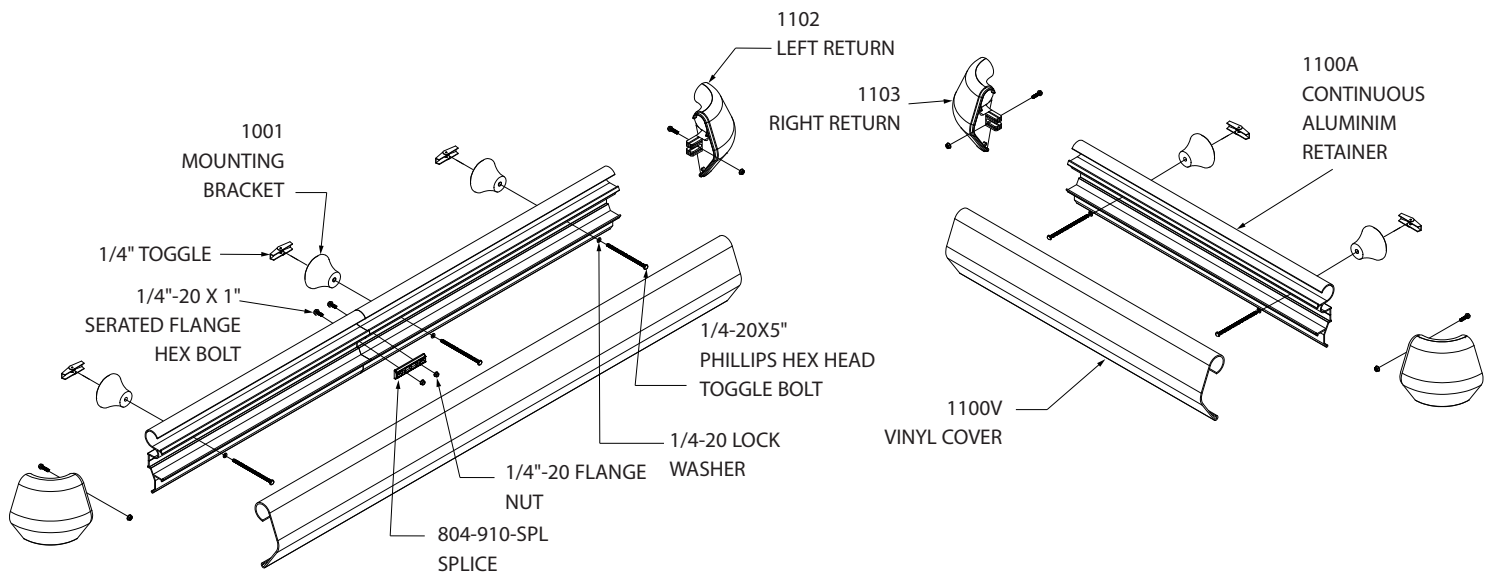

IPC® Door + Wall Protection

inpro.com • 800.222.5556 • 262.679.9010

World Headquarters S80 W18766 Apollo Drive, Muskego, WI 53150 USA

Installation Hotline: 866.394.6776

inpro®

Installation Instructions

1100/G2-1100 Handrails

Please read all instructions before installing handrail.

FIG. 1

Please read all instructions before installing handrail.

1. Cut aluminum retainer to desired length, leaving allowance for returns and outside corners. See Figure 1.

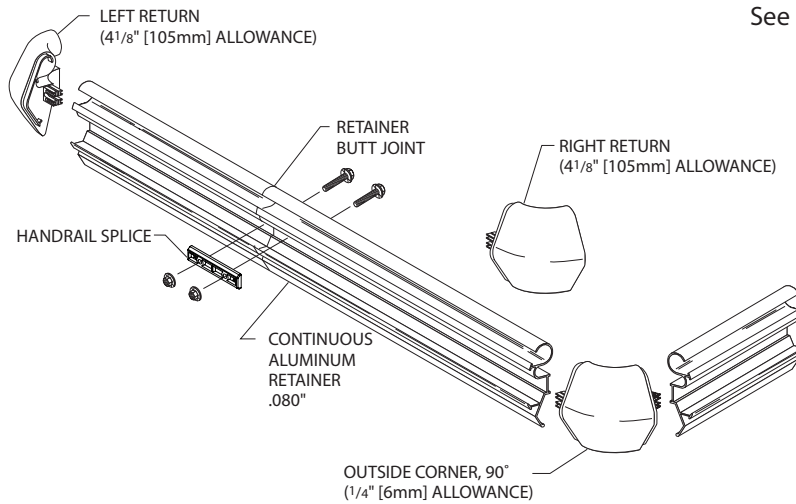
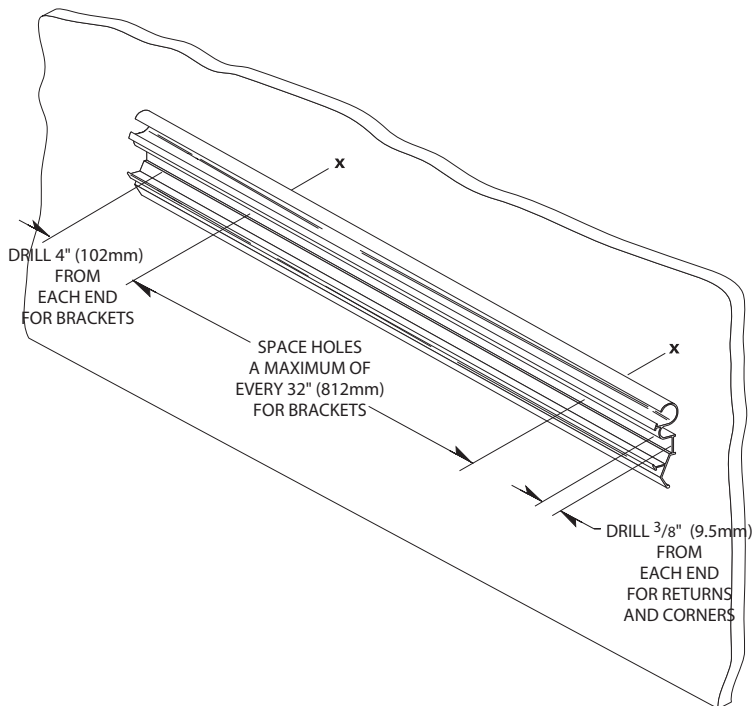

FIG. 2

2. Drill holes in centerline of aluminum retainer for brackets, returns, corners and splices using 1/4" (6mm) drill bit. Position aluminum retainer against wall at desired height allowing for returns and corners. Level and mark bracket holes on wall. Drill marked holes with 3/4" (19mm) drill bit for toggle bolts (drywall installation) or 1/2" (13mm) drill bit for lead anchor (concrete wall installation). See Figure 2.



IPC® Door + Wall Protection

inpro.com • 800.222.5556 • 262.679.9010

World Headquarters S80 W18766 Apollo Drive, Muskego, WI 53150 USA

Installation Hotline: 866.394.6776

inpro®

Installation Instructions

1100/G2-1100 Handrails

Please read all instructions before installing handrail.

FIG. 3

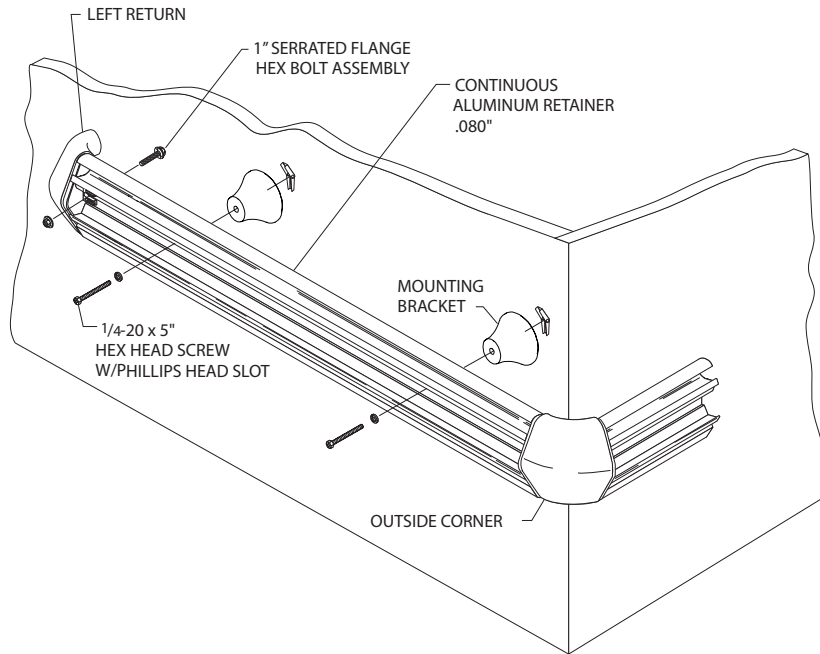

3. Attach returns and corners to retainer leaving a 1/16" (1.5mm) gap between returns/corners and retainer to allow for adjustment. Loosely attach brackets to retainer. Mount on wall, level retainer and tighten screws to secure. See Figure 3.

3a. For long runs of handrail, secure each section of aluminum retainer to the next with the supplied splice piece.

NOTE: Make sure you install the splice with side "A" facing out.

FIG. 4

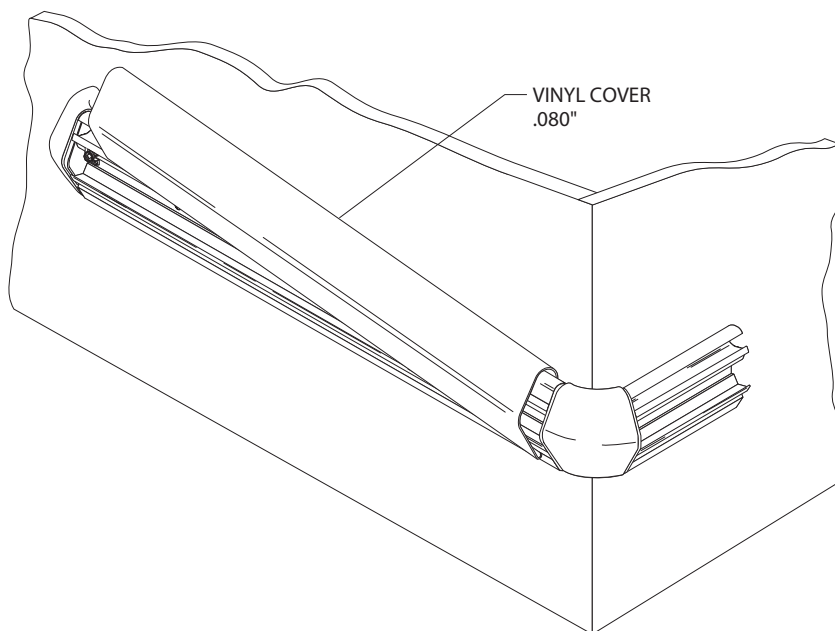

4. Cut vinyl cover to length between returns and/or corners. (Note: Trim factory edges square before installation). Position cover on retainer and adjust returns and/or corners for a tight fit. Snap cover on retainer by starting at top and pivoting over the bottom of retainer. See Figure 4.

IPC® Door + Wall Protection

inpro.com • 800.222.5556 • 262.679.9010

World Headquarters S80 W18766 Apollo Drive, Muskego, WI 53150 USA

Installation Hotline: 866.394.6776

inpro®