

Design Chart						
System	Joint Width @ 60° F [16°C]		Seal Height		Movement Range	
	US	mm	US	mm	US	mm
1150-100	1"	25	2"	51	.5-1.25	13-32
1150-200	2"	51	2"	51	1-2.5	25-64
1150-300	3"	76	3"	76	1.5-3.75	38-95
1150-400	4"	102	4"	101	2-5	51-127
1150-500	5"	127	4"	101	2.5-6.25	63-159
1150-600	6"	152	4"	101	3-7.5	76-191
1150-700	7"	178	5"	127	3.5-8.75	83-222
1150-800	8"	203	5"	127	4-6	101-152

Available in other sizes in 1/2" increments (up to 12")

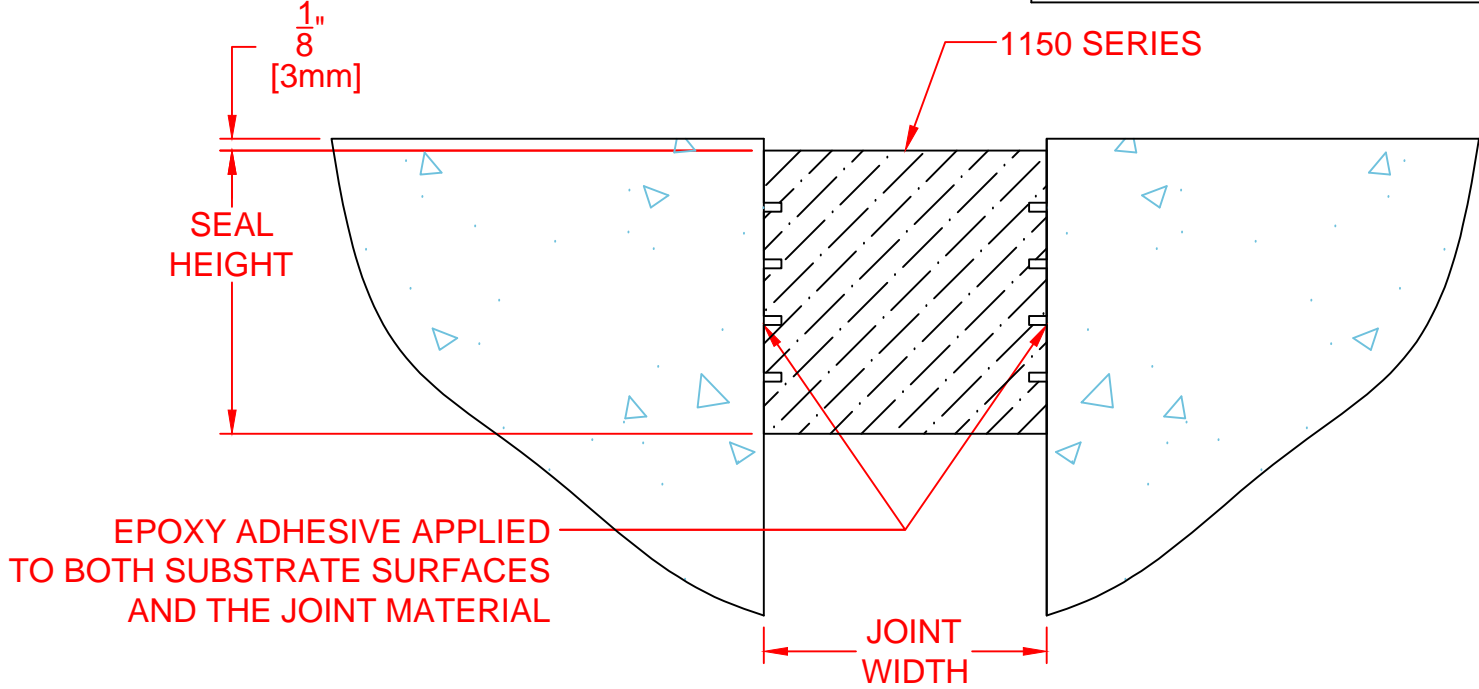

**JOINTMASTER™**  
EXPANSION JOINT SYSTEMS

DATE: 7-1-13  
SCALE: NTS  
DOC: CADJM.222/Rev2

1150 APPLICATION  
FLOOR TO FLOOR

