

# 140D Flush Mount

End Wall Protector

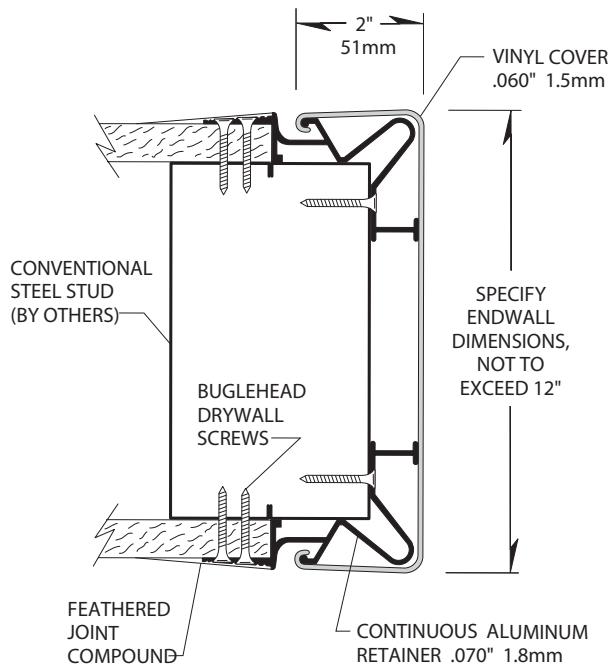

- Protect end wall conditions from damage
- Provides 2" (51mm) wing corner protection
- Mounted on a sturdy .070" (1.8mm) pre-punched continuous aluminum retainer
- .060" (1.5mm) thick scratch and stain resistant rigid vinyl cover
- Manufactured in 4' (1.22m), 8' (2.44m), 9' (2.74m) and 10' (3.05m) standard heights
- All mounting fasteners are included with each order
- Meets the most rigorous standards and criteria of chemical emissions as prescribed by the GREENGUARD Environmental Institute
- Has been tested and meets GREENGUARD Environmental Institute's and the state of California's requirements for low emitting products as tested by Air Quality Sciences
- Has been tested and meets the GREENGUARD Children & School chemical emissions levels

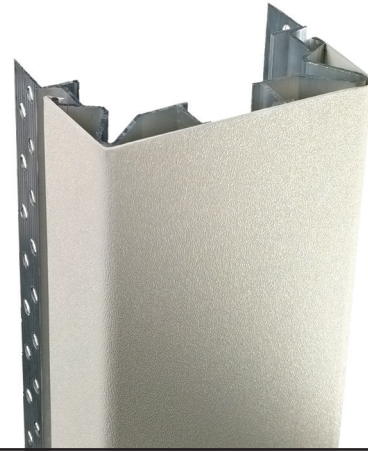

IPC.412/REV.8

# 140D Flush Mount End Wall Protector

## Suggested Specifications

### PART 1 - GENERAL

#### 1.01 SUMMARY

A. End wall protector system for wall protection

#### 1.02 SECTION INCLUDES

A. 140D Flush Mount End Wall Protector System

#### 1.03 REFERENCES

A. American Society for Testing and Materials (ASTM)

B. National Building Code of Canada (NBC)

C. National Fire Protection Association (NFPA)

D. Society of Automotive Engineers (SAE)

E. Underwriters Laboratory (UL)

F. Underwriters Laboratory of Canada (ULC)

G. Uniform Building Code (UBC)

#### 1.04 SYSTEM DESCRIPTION

A. Performance Requirements: Provide end wall protector systems that conform to the following requirements of regulatory agencies and the quality control of IPC Door and Wall Protection Systems, InPro Corporation.

1. Fire Performance Characteristics: Provide UL Classified end wall protectors conforming with NFPA Class A fire rating. Surface burning characteristics, as determined by UL-723 (ASTM E-84), shall be flame spread of 10 and smoke development of 350 - 450. Provide ULC (Canada) listed end wall protectors conforming to the requirements of the National Building Code of Canada 2010, Subsection 3.1.13. Surface burning characteristics, as determined by CAN/ULC-S102.2, shall be flame spread of 15 and smoke developed of 35.

2. Self Extinguishing: Provide end wall protectors with a CC1 classification, as tested in accordance with the procedures specified in ASTM D-635-74, Standard Test Method for Rate of Burning and/or Extent and Time of Burning of Self-Supporting Plastics in a Horizontal Position, as referenced in UBC 52-4-1988.

3. Impact Strength: Provide rigid vinyl profile materials that have an Impact Strength of 30.4 ft-lbs/inch of thickness as tested in accordance with the procedures specified in ASTM D-256-90b, Impact Resistance of Plastics.

4. Chemical and Stain Resistance: Provide end wall protectors that show resistance to stain when tested in accordance with applicable provisions of ASTM D-543.

5. GREENGUARD Certified: Provide GREENGUARD Certified material. Profiles shall meet the requirements of GREENGUARD Certification Standards for Low-Emitting Products and GREENGUARD Product Emission Standard for Children & Schools.

6. Fungal and Bacterial Resistance: Provide rigid vinyl that does not support fungal or bacterial growth as tested in accordance with ASTM G-21 and ASTM G-22.

7. Color Consistency: Provide components matched in

accordance with SAE J-1545 - (Delta E) with a color difference no greater than 1.0 units using CIE Lab, CIE CMC, CIE LCh, Hunter Lab or similar color space scale systems.

#### 1.05 SUBMITTALS

A. Product Data: Manufacturer's printed product data for each type of end wall protector specified.

B. Detail Drawings: Mounting details with the appropriate adhesives for specific project substrates.

C. Samples: Verification samples of end wall protector, 8" (203mm) long, in full size profiles of each type and color indicated.

D. Manufacturer's Installation Instruction: Printed installation instructions for each end wall protector.

#### 1.06 DELIVERY, STORAGE AND HANDLING

A. Deliver materials in unopened factory packaging to the jobsite

B. Inspect materials at delivery to assure that specified products have been received.

C. Store in original packaging in a climate controlled location away from direct sunlight.

#### 1.07 PROJECT CONDITIONS

A. Environmental Requirements: Products must be installed in an interior climate controlled environment.

#### 1.08 WARRANTY

A. Standard IPC Limited Lifetime Warranty against material and manufacturing defects.

### PART 2 - PRODUCTS

#### 2.01 MANUFACTURER

A. Acceptable Manufacturer: IPC Door and Wall Protection Systems, InPro Corporation, PO Box 406 Muskego, WI 53150 USA; Telephone: 800.222.5556, Fax: 888.715.8407, www.inprocorp.com

B. Substitutions: Not permitted

C. Provide all end wall protectors and wall protection from a single source.

#### 2.02 MANUFACTURED UNITS

A. Corner Guard System

1. 140D Flush Mount End Wall Protector Profile  
2" (51mm) Returns  
4' (1.22m), 8' (2.44m), 9' (2.74m) and 10' (3.05m) standard heights

#### 2.03 MATERIALS

A. Vinyl: Snap on cover of .060" (1.5mm) thickness shall be made from chemical and stain-resistant unplasticized polyvinyl chloride (uPVC) with the addition of impact modifiers. No plasticizers shall be added (plasticizers may aid in bacterial growth).

B. Aluminum: Continuous aluminum retainer of .070" (1.8mm) thickness shall be fabricated from 6063-T5 aluminum, with a mill finish.

#### 2.04 COMPONENTS

A. Fasteners: All mounting system accessories appropriate for substrates indicated on the drawings shall be provided.

#### 2.05 FINISHES

A. Vinyl Cover: Color of end wall protector to be selected by the architect from the IPC finish selection. Surface shall have a pebble texture.

### PART 3 - EXECUTION

#### 3.01 EXAMINATION

A. Examine areas and conditions in which the end wall protector systems will be installed.

B. Wall surface shall be dry and free from dirt, grease and loose paint.

#### 3.02 PREPARATION

A. General: Prior to installation, clean substrate to remove dust, debris and loose particles.

#### 3.03 INSTALLATION

A. General: Locate the end wall protector as indicated on the approved detail drawing for the appropriate substrate and in compliance with the IPC installation instructions. Install end wall protector level and plumb at the height indicated on the drawings.

B. Installation of 140D End Wall Protector:

1. Position the aluminum retainers on the exposed stud at the end of the wall. The 5/8" (16mm) drywall should be held back 1 1/2" (38mm) from the corners of the end stud. The mounting flange of the retainer rests over the edge of the drywall.

2. Attach the aluminum retainer to the studs using 1 1/4" bugle head drywall screws 18" (457mm) on center and 12" on center along the front face.

3. Use joint compound to cover the mounting flange. Feather and finish with the surface of the drywall.

4. After the drywall has been finished, position the vinyl cover over the aluminum retainer. Push the vinyl cover over the aluminum until it snaps into place, working your way down until the entire cover is secure.

#### 3.04 CLEANING

A. At completion of the installation, clean surfaces in accordance with the IPC clean-up and installation instructions.