

160 European High Impact

Corner Guard

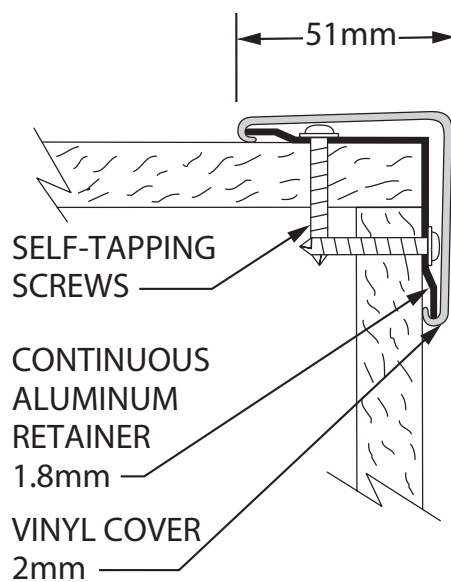

- 2" (51mm) with 90° corner protection
- Mounted on a sturdy .070" (1.8mm) continuous aluminum container
- .080" (2mm) thick scratch and stain resistant rigid vinyl cover
- Manufactured in 12' (3.66m) standard heights
- All mounting fasteners and top and bottom caps are included with each order
- Available in 100 standard colors and Woodland patterns
- Meets the most rigorous standards and criteria of chemical emissions as prescribed by the GREENGUARD Environmental Institute
- Has been tested and meets GREENGUARD Environmental Institute's and the state of California's requirements for low emitting products as tested by Air Quality Sciences
- Has been tested and meets the GREENGUARD Children & School chemical emissions levels



IPC.3253/REV.2

160 High Impact Corner Guard

Suggested Specifications

PART 1 - GENERAL

1.01 SUMMARY

A. Corner guard system for wall protection

1.02 SECTION INCLUDES

A. 160 High Impact Surface Mount Corner Guard System

1.03 REFERENCES

A. American Society for Testing and Materials (ASTM)

B. National Building Code of Canada (NBC)

C. National Fire Protection Association (NFPA)

D. Society of Automotive Engineers (SAE)

E. Underwriters Laboratory (UL)

F. Underwriters Laboratory of Canada (ULC)

G. Uniform Building Code (UBC)

1.04 SYSTEM DESCRIPTION

A. Performance Requirements: Provide corner guard system that conform to the following requirements of regulatory agencies and the quality control of IPC Door and Wall Protection Systems, InPro Corporation.

1. Fire Performance Characteristics: Provide UL Classified corner guards conforming with NFPA Class A fire rating. Surface burning characteristics, as determined by UL-723 (ASTM E-84), shall be flame spread of 10 and smoke development of 350 - 450. Provide ULC (Canada) listed corner guards conforming to the requirements of the National Building Code of Canada 2010, Subsection 3.1.13. Surface burning characteristics, as determined by CAN/ULC-S102.2, shall be flame spread of 15 and smoke developed of 35.

2. Self Extinguishing: Provide corner guards with a CC1 classification, as tested in accordance with the procedures specified in ASTM D-635-74, Standard Test Method for Rate of Burning and/or Extent and Time of Burning of Self-Supporting Plastics in a Horizontal Position, as referenced in UBC 52-4-1988.

3. Impact Strength: Provide rigid vinyl profile materials that have an Impact Strength of 30.2 ft-lbs/inch of thickness as tested in accordance with the procedures specified in ASTM D-256-90b, Impact Resistance of Plastics.

4. Chemical and Stain Resistance: Provide corner guards that show resistance to stain when tested in accordance with applicable provisions of ASTM D-543.

5. GREENGUARD Certified: Provide GREENGUARD Certified material. Profiles shall meet the requirements of GREENGUARD Certification Standards for Low-Emitting Products and GREENGUARD Product Emission Standard for Children & Schools.

6. Fungal and Bacterial Resistance: Provide rigid vinyl that does not support fungal or bacterial growth as tested in accordance with ASTM G-21 and ASTM G-22.

7. Color Consistency: Provide components matched in accordance with SAE J-1545 - (Delta E) with a color difference no greater than 1.0 units using CIE Lab, CIE CMC, CIE LCh, Hunter Lab or similar color space scale systems.

1.05 SUBMITTALS

A. Product Data: Manufacturer's printed product data for each type of corner guard specified.

B. Detail Drawings: Mounting details with the appropriate adhesives for specific project substrates.

C. Samples: Verification samples of corner guard, 8" (203mm) long, in full size profiles of each type and color indicated.

D. Manufacturer's Installation Instruction: Printed installation instructions for each corner guard.

1.06 DELIVERY, STORAGE AND HANDLING

A. Deliver materials in unopened factory packaging to the jobsite

B. Inspect materials at delivery to assure that specified products have been received.

C. Store in original packaging in a climate controlled location away from direct sunlight.

1.07 PROJECT CONDITIONS

A. Environmental Requirements: Products must be installed in an interior climate controlled environment.

1.08 WARRANTY

A. Standard IPC Limited Lifetime Warranty against material and manufacturing defects.

PART 2 - PRODUCTS

2.01 MANUFACTURER

A. Acceptable Manufacturer: Inpro Europe, Artist House, 1st Floor, 35 Little Russell Street, London, WC1A 2HH
Tel: +0044(0)7399586677

Web: www.inprocorp.co.uk

B. Substitutions: Not permitted

C. Provide all corner guards and wall protection from a single source.

2.02 MANUFACTURED UNITS

A. Corner Guard System

160 European High Impact Surface Mount Corner Guard Profile
2" (51mm) x 2" (51mm), 90 degree, 12' (3.65m) standard height.

2.03 MATERIALS

A. Vinyl: Snap on cover of .080" (2mm) thickness shall be made from chemical and stain-resistant unplasticized polyvinyl chloride (uPVC) with the addition of impact modifiers. No plasticizers shall be added (plasticizers may aid in bacterial growth).

B. Aluminum: Continuous aluminum retainer of .070" (1.8mm) thickness shall be fabricated from 6063-T5 aluminum, with a mill finish.

2.04 COMPONENTS

A. Top caps and bottom caps shall be made of injection molded thermoplastics.

B. Fasteners: All mounting system accessories appropriate for substrates indicated on the drawings shall be provided.

C. Optional flexible top caps shall be made of injection molded Biopolymer Flex PVC.

2.05 FINISHES

A. Vinyl Covers: Colors of the corner guard to be selected by the architect from the IPC finish selection. Surface shall have a pebblette texture.

B. Molded Components: Top caps and bottom caps shall be of a color matching the corner guards. Surface shall have a pebblette texture.

PART 3 - EXECUTION

3.01 EXAMINATION

A. Examine areas and conditions in which the corner guard systems will be installed.

1. Complete all finishing operations, including painting, before beginning installation of corner guard system materials.

B. Wall surface shall be dry and free from dirt, grease and loose paint.

3.02 PREPARATION

A. General: Prior to installation, clean substrate to remove dust, debris and loose particles.

3.03 INSTALLATION

A. General: Locate corner guard as indicated on the

approved detail drawings for the appropriate substrate and in compliance with the IPC installation instructions. Install corner guard level and plumb at the height indicated on drawings.

B. Installation of 160 High Impact Surface Mount Corner Guard:

1. Position the aluminum retainer against the wall, allowing 8mm from the bottom of the aluminum to the top of the cove base or baseboard for the bottom cap.

2. Aluminum Retainer Installation

Drywall installation: Secure the aluminum retainer to the wall using M4.2 x 38mm phillips round head self-tapping screws. Use 6 screws per 1.22m length, 10 screws per 2.44m length, 12 screws per 2.74m length, or 16 per 3.6m length.

Concrete installation: Drill 6.5mm holes into the ends of the retainer for top and bottom caps. Use the slotted tabs of the top caps as a template for hole location. Transfer the location of all mounting holes to the wall. Drill 1/4" (6.5mm) holes and position ALLIGATOR anchors into the holes on the wall. Mount the retainer with M4.8 x 38 mm phillips pan head screws and tighten to secure the retainer to the wall.

3. Top and Bottom Cap Installation

Drywall installation: Overlap the aluminum with the mounting tabs of the top cap and attach them to the aluminum retainer using two, 38mm phillips flat head self tapping screws per cap.

Concrete installation: Overlap the aluminum with the mounting tabs of the top and bottom caps and attach them to the aluminum retainer using two, M4.2 x 38 mm phillips flat head screws per cap. When installing flexible top caps on custom angle corner guards, use cup washers and flat head screws to fasten the top caps to the retainer.

4. Position the vinyl cover on the aluminum retainer to check the fit. Adjust the top cap on the aluminum retainer to obtain a tight fit with the vinyl cover. Starting at the top, push the vinyl cover over the aluminum, by pressing over the length until the vinyl snaps securely into place.

3.04 CLEANING

A. At completion of the installation, clean surfaces in accordance with the IPC clean-up and maintenance instructions.