

# 2500/2500W

## Chair Rail



2500



2500W

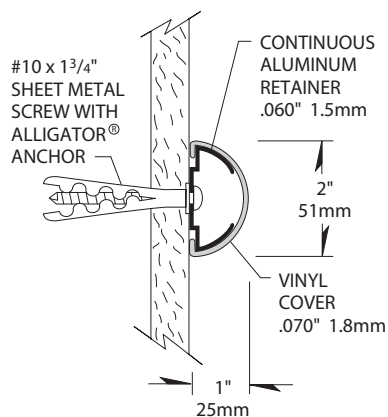

- 2" (51mm) of wall protection, extends 1" (25mm) from wall
- Mounted on a sturdy .060" (1.5mm) thick, continuous aluminum retainer
- .070" (1.8mm) thick, durable, rigid vinyl cover
- Scratch and stain resistant woodgrain texture
- 2500W includes black reveals for end caps and corners
- Easy installation, clean-up and maintenance
- Manufactured in 12' (3.66m) standard lengths
- All mounting fasteners are included with each order
- 2500W Model - Manufactured with woodland pattern full wrap.
- Meets the most rigorous standards and criteria of chemical emissions as prescribed by the GREENGUARD Environmental Institute
- Has been tested and meets GREENGUARD Environmental Institute's and the state of California's requirements for low emitting products as tested by Air Quality Sciences
- Has been tested and meets the GREENGUARD Children & School chemical emissions levels



IPC.364/REV.8

# 2500/2500W Chair Rail

## Suggested Specifications

### PART 1 - GENERAL

#### 1.01 SUMMARY

A. Chair rail system for wall protection and decoration

#### 1.02 SECTION INCLUDES

A. 2500/2500W Chair Rail System

#### 1.03 REFERENCES

A. American Society for Testing and Materials (ASTM)

B. National Building Code of Canada (NBC)

C. National Fire Protection Association (NFPA)

D. Society of Automotive Engineers (SAE)

E. Underwriters Laboratory (UL)

F. Underwriters Laboratory of Canada (ULC)

G. Uniform Building Code (UBC)

#### 1.04 SYSTEM DESCRIPTION

A. Performance Requirements: Provide chair rail systems that conform to the following requirements of regulatory agencies and the quality control of IPC Door and Wall Protection Systems, InPro Corporation.

1. Fire Performance Characteristics: Provide UL Classified chair rails conforming with NFPA Class A fire rating.

Surface burning characteristics, as determined by UL-723 (ASTM E-84), shall be flame spread of 10 and smoke development of 350 - 450. Provide ULC (Canada) listed chair rails conforming to the requirements of the National Building Code of Canada 2010, Subsection 3.1.13. Surface burning characteristics, as determined by CAN/ULC-S102.2, shall be flame spread of 15 and smoke developed of 35.

2. Self Extinguishing: Provide chair rails with a CC1 classification, as tested in accordance with the procedures specified in ASTM D-635-74, Standard Test Method for Rate of Burning and/or Extent and Time of Burning of Self-Supporting Plastics in a Horizontal Position, as referenced in UBC 52-4-1988.

3. Impact Strength: Provide rigid vinyl profile materials that have an Impact Strength of 30.2 ft-lbs/inch of thickness as tested in accordance with the procedures specified in ASTM D-256-90b, Impact Resistance of Plastics.

4. Chemical and Stain Resistance: Provide chair rails that show resistance to stain when tested in accordance with applicable provisions of ASTM D-543.

5. GREENGUARD Certified: Provide GREENGUARD Certified material. Profiles shall meet the requirements of GREENGUARD Certification Standards for Low-Emitting Products and GREENGUARD Product Emission Standard for Children & Schools.

6. Fungal and Bacterial Resistance: Provide rigid vinyl that does not support fungal or bacterial growth as tested in accordance with ASTM G-21 and ASTM G-22.

7. Color Consistency: Provide components matched in accordance with SAE J-1545 - (Delta E) with a color difference no greater than 1.0 units using CIE Lab, CIE CMC, CIE LCh, Hunter Lab or similar color space scale systems.

#### 1.05 SUBMITTALS

A. Product Data: Manufacturer's printed product data for each type of chair rail specified.

B. Detail Drawings: Mounting details with the appropriate fasteners for specific project substrates.

C. Samples: Verification samples of chair rail, 8" (203mm) long, in full size profiles of each type and color indicated.

D. Manufacturer's Installation Instruction: Printed installation instructions for each chair rail.

#### 1.06 DELIVERY, STORAGE AND HANDLING

A. Deliver materials in unopened factory packaging to the jobsite

B. Inspect materials at delivery to assure that specified products have been received.

C. Store in original packaging in a climate controlled location away from direct sunlight.

#### 1.07 PROJECT CONDITIONS

A. Environmental Requirements: Products must be installed in an interior climate controlled environment.

#### 1.08 WARRANTY

A. Standard IPC Limited Lifetime Warranty against material and manufacturing defects.

### PART 2 - PRODUCTS

#### 2.01 MANUFACTURER

A. Acceptable Manufacturer:  
IPC Door and Wall Protection Systems, InPro Corporation, PO Box 406 Muskego, WI 53150 USA; Telephone: 800.222.5556, Fax: 888.715.8407, www.inprocorp.com

B. Substitutions: Not permitted

C. Provide all chair rails and wall protection from a single source.

#### 2.02 MANUFACTURED UNITS

A. Chair Rail Profile

1. 2500 Chair Rail, 2" (51mm) height x 1" (25mm) depth

2. 2500W Chair Rail, 2" (51mm) height x 1" (25mm) depth. Wall guard shall have a full-wrap woodgrain pattern. Black reveals for end caps and corners.

#### 2.03 MATERIALS

A. Vinyl: Snap on cover of .080" (2mm) thickness shall be made from chemical and stain-resistant unplasticized polyvinyl chloride (uPVC) with the addition of impact modifiers. No plasticizers shall be added (plasticizers may aid in bacterial growth).

B. Aluminum: Continuous aluminum retainer of .060" (1.5mm) thickness shall be fabricated from 6063-T5 aluminum, with a mill finish.

#### 2.04 COMPONENTS

A. End caps, outside corners and inside corners shall be made of injection molded thermoplastics.

B. Molded reveals shall have a smooth finish and shall be black.

C. Fasteners: All mounting system accessories appropriate for substrates indicated on the drawings shall be provided.

#### 2.05 FINISHES

A. Vinyl Covers: Colors of the chair rail to be selected by the architect from the IPC finish selection. Surface shall have a woodgrain texture.

B. Molded Components: End caps, outside corners and inside corners shall be of a color matching the chair rail. Surface shall have a woodgrain texture.

### PART 3 - EXECUTION

#### 3.01 EXAMINATION

A. Examine areas and conditions in which the chair rail systems will be installed.

1. Complete all finishing operations, including painting, before beginning installation of chair rail system materials.

B. Wall surface shall be dry and free from dirt, grease and loose paint.

#### 3.02 PREPARATION

A. General: Prior to installation, clean substrate to remove dust, debris and loose particles.

#### 3.03 INSTALLATION

A. General: Locate the chair rail as indicated on the approved detail drawing for the appropriate substrate and in compliance with the IPC installation instructions. Install chair rail level and plumb at the height indicated on the drawings.

B. Installation of 2500/2500W Chair Rail:

1. Cut the aluminum retainer to the desired length, allowing 1<sup>5</sup>/<sub>16</sub>" (33mm) for each end cap and inside corner, 5<sup>7</sup>/<sub>16</sub>" (8mm) for each outside corner and 2<sup>5</sup>/<sub>16</sub>" (59mm) for each picture frame corner.

2. Using a 1<sup>1</sup>/<sub>4</sub>" drill bit, drill holes in the centerline of the aluminum retainer 4" (102mm) from each end and spaced evenly over the entire length (6 anchors per 12' (3.66m) length).

3. Position and level the aluminum retainer on the wall, allowing for end caps, inside corners, and outside corners, and transfer mounting holes to the wall with a marker. Drill 1<sup>1</sup>/<sub>4</sub>" (6mm) holes at each mark and position the ALLIGATOR anchors into the holes on the wall. Mount the retainer with #10 x 1<sup>3</sup>/<sub>4</sub>" phillips pan head screws and tighten the screws to secure the retainer.

4. (2500W - Slide reveals onto end caps and corners.) Slide the end caps, inside corners, outside corners or picture frame corners onto the aluminum, leaving a 1<sup>1</sup>/<sub>16</sub>" gap for adjustments, and secure them by using one 1<sup>1</sup>/<sub>4</sub>" self-tapping screw per end cap or two per corner.

5. Cut the vinyl cover to the distance between the end caps/corners. NOTE: Trim all factory edges square before installation. Position the vinyl cover on the aluminum retainer starting at one end and working to the other end by pushing the cover over the aluminum until it snaps into place.

#### 3.04 CLEANING

A. At completion of the installation, clean surfaces in accordance with the IPC clean-up and maintenance instructions.