

# 27 1/2" Folding Bench Seat with Legs (Phenolic) Installation Instructions

Please read all instructions before installing products

Local codes vary from state to state. Check your local codes before installing the L-Shaped Folding Bench Seat. Consult the ADA Standards for any ADA Compliant installs.

**FIG.1**

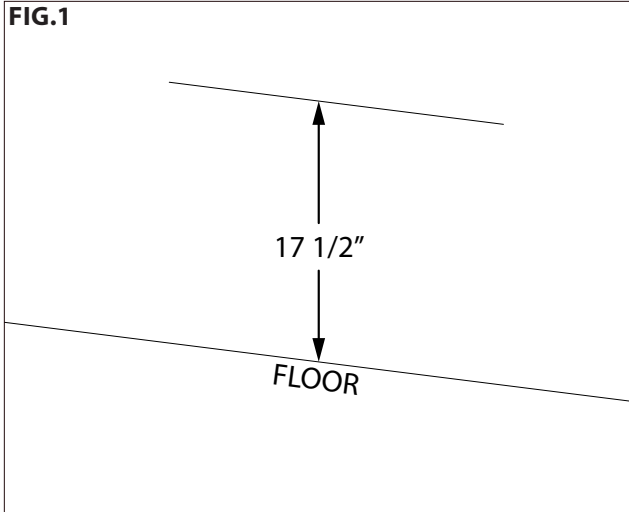

**Note:**

- Install bench seats into solid wall sub-structure or backing plates.
  - These instructions are intended for wood stud walls and/or blocking. If wall conditions vary use fasteners suitable for the wall conditions on which the product will be installed.
1. Remove the Folding Bench Seat from the box and locate the included template.
- Using a level, draw a line on the wall, 17 1/2" above the floor, where the Folding Bench Seat will be installed. *See Figure 1.*
2. Attach the template to the wall, with the top edge of the template aligned with the line you drew in the previous step. *See Figure 2.*
  3. Transfer the hole pattern to the wall with a pencil. *See Figures 3.*
  4. Drill 7/32" pilot holes 2 1/2" deep into the wall at each hole location. *See Figure 4.*

Using a level, draw a line on the wall, 17 1/2" above the floor, where the Folding Bench Seat will be installed. *See Figure 1.*

**FIG.2**

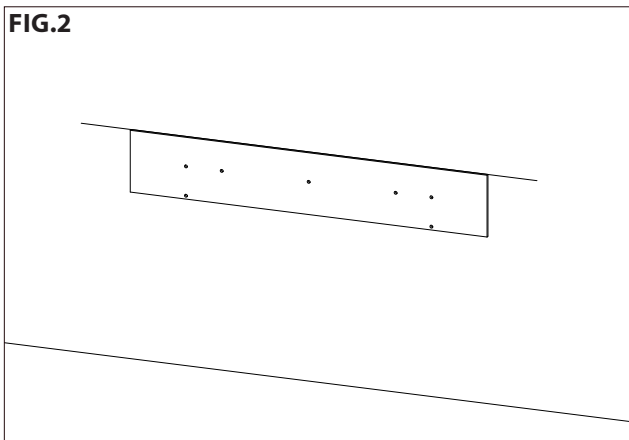

**FIG.3**

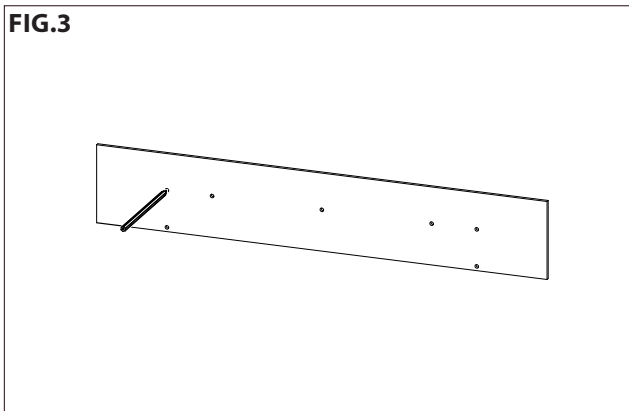

**FIG.4**

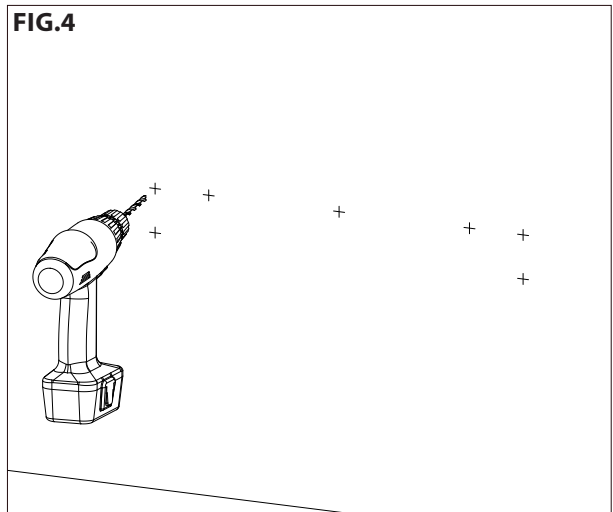

IPC.3284/REV.1

ENDURANT® Washroom Systems

inpro.com • 800.222.5556 • 262.679.9010

World Headquarters S80 W18766 Apollo Drive, Muskego, WI 53150 USA

Installation Hotline: 866.394.6776

**inpro**®

# 27 1/2" Folding Bench Seat with Legs (Phenolic)

## Installation Instructions

FIG.5

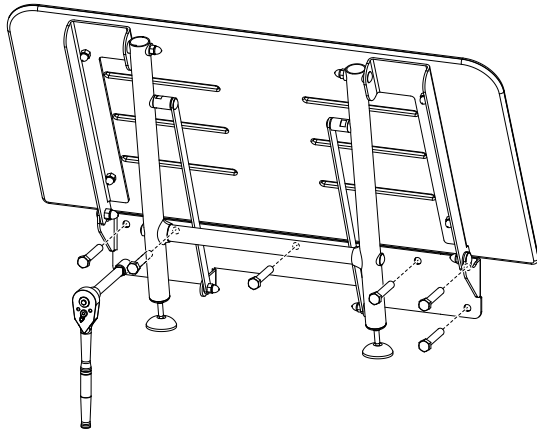

6. Attach the Folding Bench Seat to the wall with the provided M8 x 70mm lag screws and a 13mm socket. *See Figure 5.*

**Caution:** Hand tighten mounting bolts to avoid damaging wall cladding. DO NOT TIGHTEN WITH POWER TOOLS.

7. Rotate the bench down into its finished position. *See Figure 6.*
8. Adjust the feet up or down to the desired height, the seat should tilt back approximately 1-2°. Once the feet are adjusted tighten the jam nut with a 13mm combination wrench. *See Figure 7.*

FIG.6

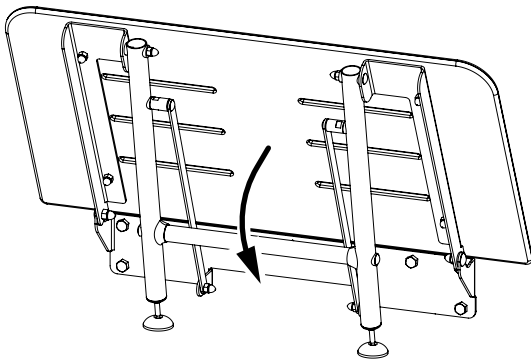
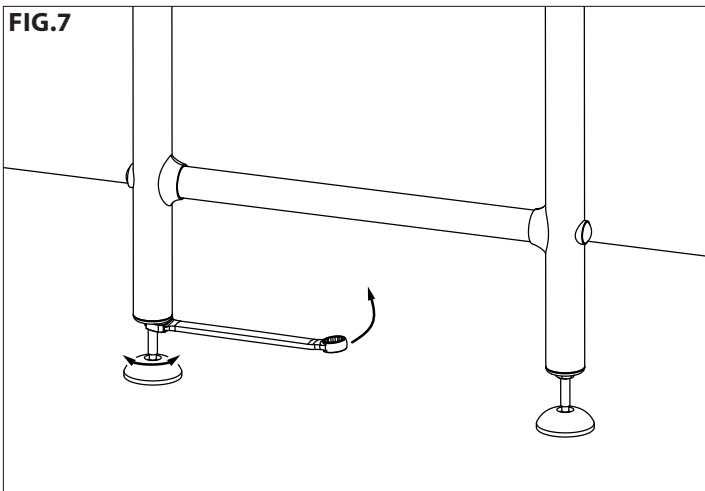

FIG.7



ENDURANT® Washroom Systems

inpro.com • 800.222.5556 • 262.679.9010

World Headquarters S80 W18766 Apollo Drive, Muskego, WI 53150 USA

Installation Hotline: 866.394.6776

**inpro**®