

Installation Instructions

30SS and 31SS Stainless Steel Wall Guard

Please read all instructions before installing wallguard.

Important

1. Acclimate materials 24 hrs before installation. Maintain temperature controlled environment after installation
2. Install in accordance with manufacturer's installation instructions. Failure to do so will void the warranty.

Installation tips

1. Cut covers up to 1/16" (1.6mm) longer to ensure a tight fit.
2. Lubricate blades when cutting aluminum to reduce burrs.

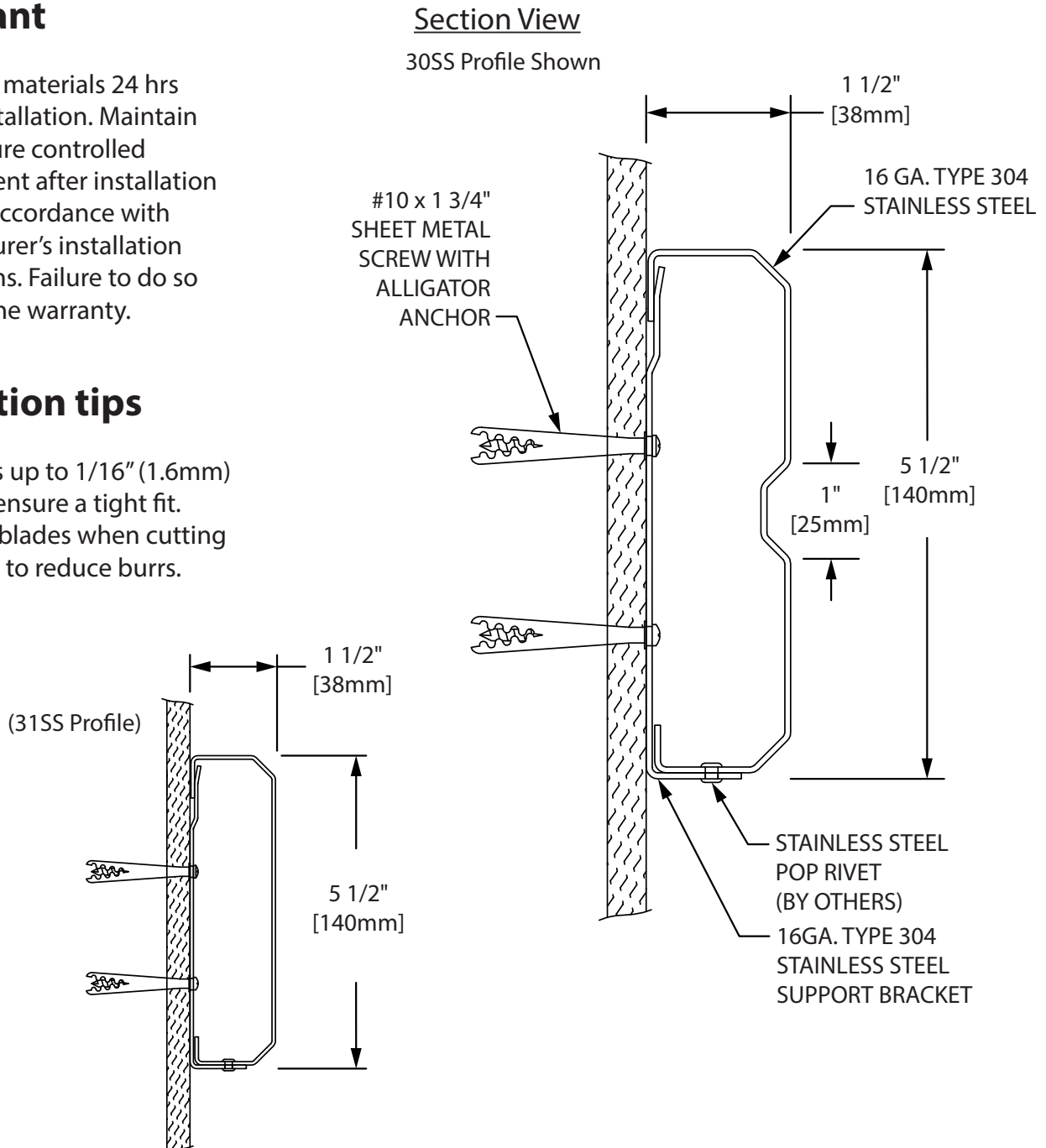

Recommended tools

Safety Glasses, Tape Measure, Level, Power Drill, Drill Bits - 1/4" masonry (concrete/concrete block), Power Miter Saw, 10" Blade with 60-80 Carbide Tipped Teeth

IPC.610/REV.5

IPC® Door + Wall Protection

inpro.com • 800.222.5556 • 262.679.9010

World Headquarters S80 W18766 Apollo Drive, Muskego, WI 53150 USA

Installation Hotline: 866.394.6776

inpro®

Installation Instructions

30SS and 31SS Stainless Steel Wall Guard

Please read all instructions before installing wallguard.

Components and fasteners

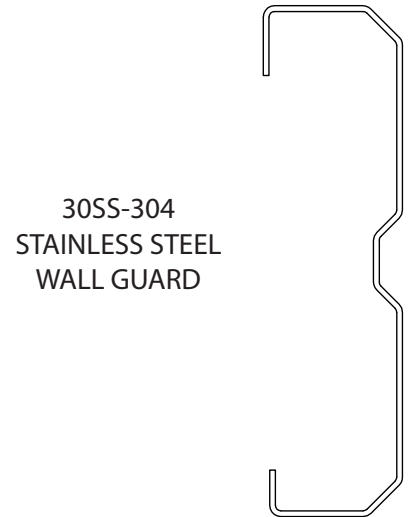
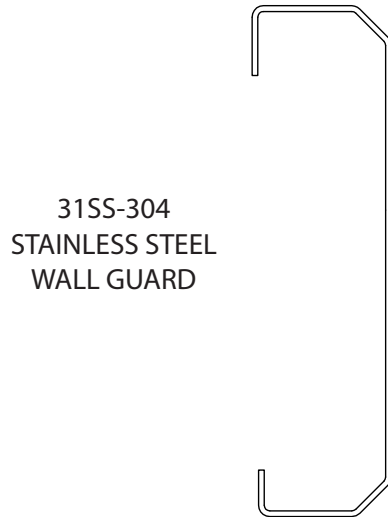
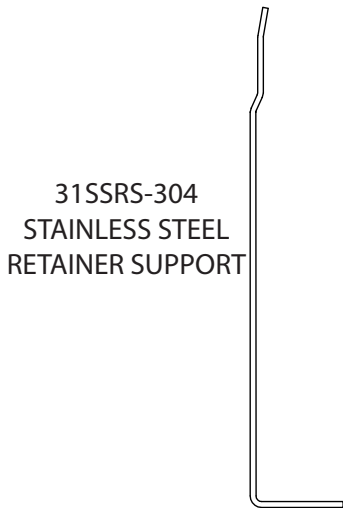
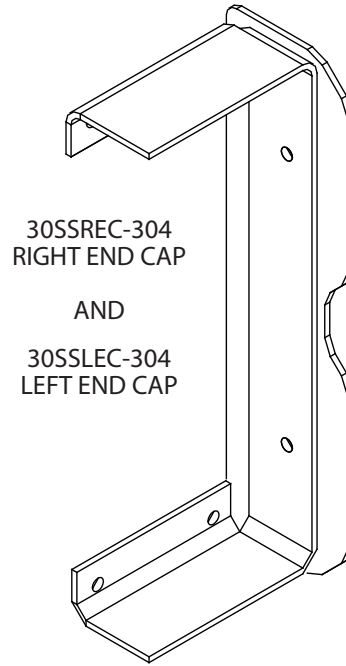
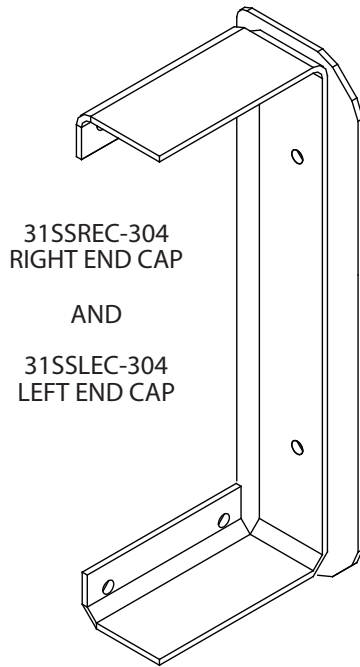

Wall Condition	Specified Fasteners	Inpro Part #
Gypsum/Concrete	#10 x 1 3/4" Phillips Pan Head Sheet Metal Screw with Alligator Anchor	HWK-CC

IPC® Door + Wall Protection

inpro.com • 800.222.5556 • 262.679.9010

World Headquarters S80 W18766 Apollo Drive, Muskego, WI 53150 USA

Installation Hotline: 866.394.6776

inpro®

Installation Instructions

30SS and 31SS Stainless Steel Wall Guard

Please read all instructions before installing wallguard.

Layout Views

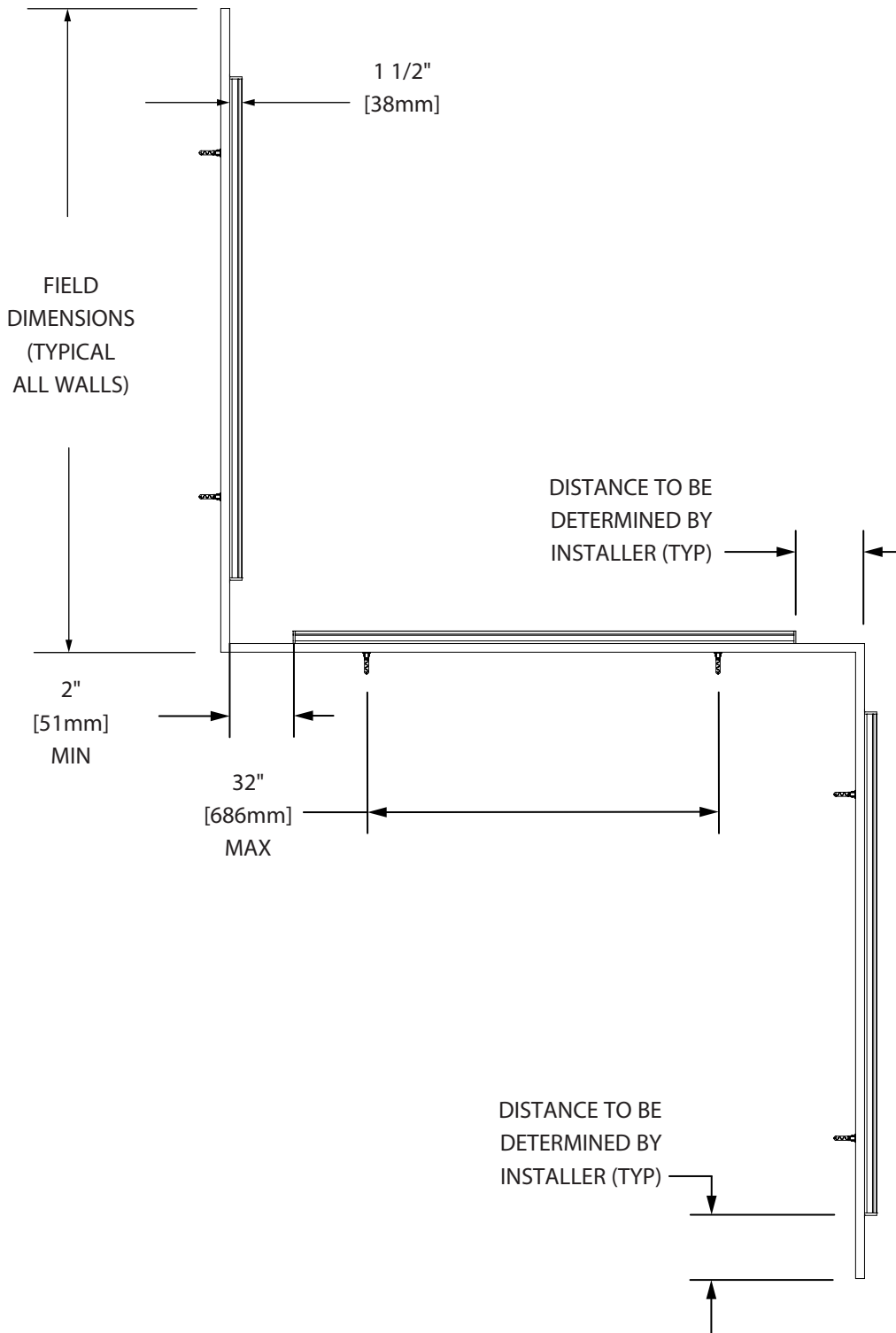

IPC® Door + Wall Protection

inpro.com • 800.222.5556 • 262.679.9010

World Headquarters S80 W18766 Apollo Drive, Muskego, WI 53150 USA

Installation Hotline: 866.394.6776

inpro®

Installation Instructions

30SS and 31SS Stainless Steel Wall Guard

Please read all instructions before installing wallguard.

Exploded Assembly

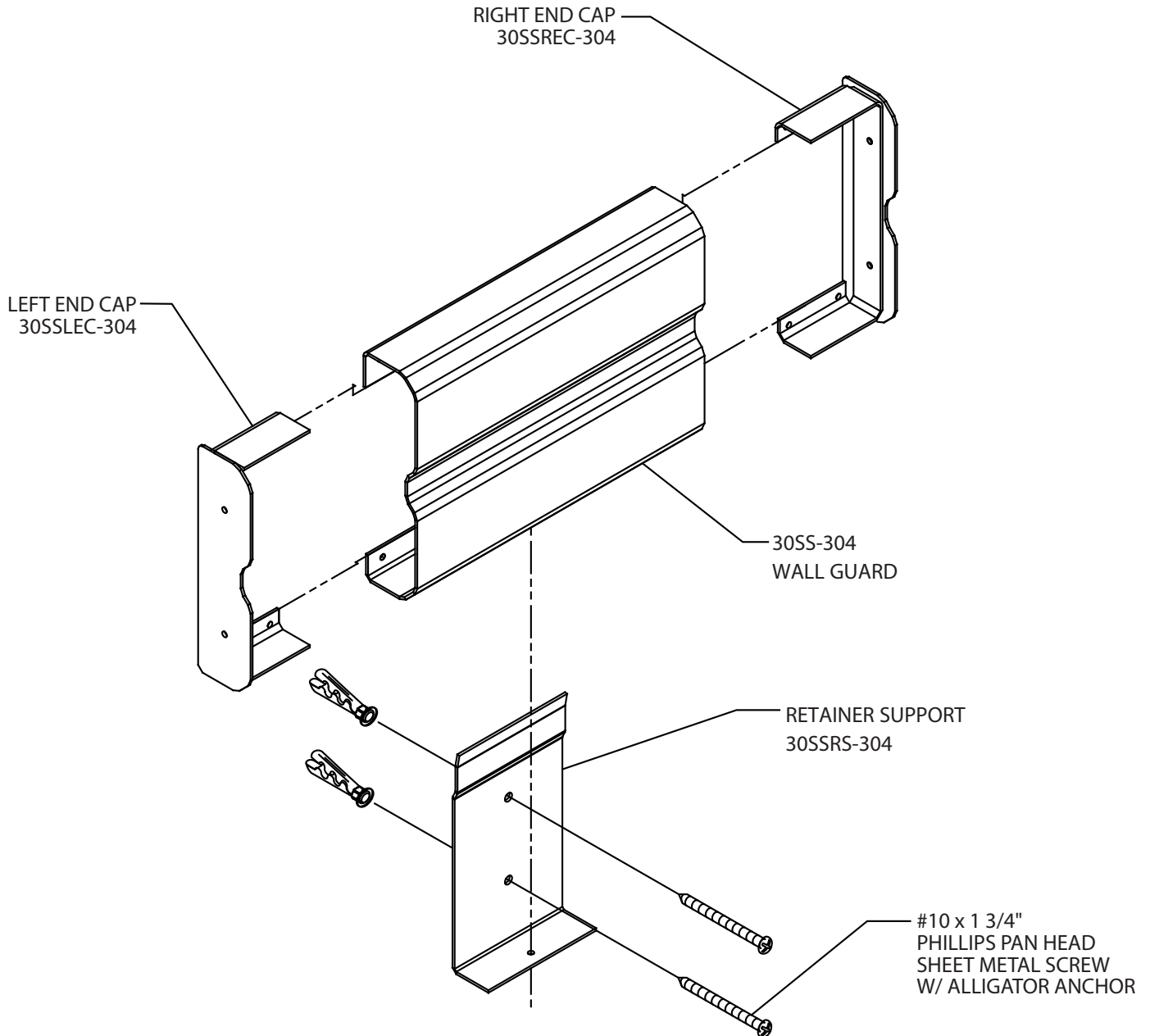

IPC® Door + Wall Protection

inpro.com • 800.222.5556 • 262.679.9010

World Headquarters S80 W18766 Apollo Drive, Muskego, WI 53150 USA

Installation Hotline: 866.394.6776

inpro®

Installation Instructions

30SS and 31SS Stainless Steel Wall Guard

Please read all instructions before installing wallguard.

FIG. 1

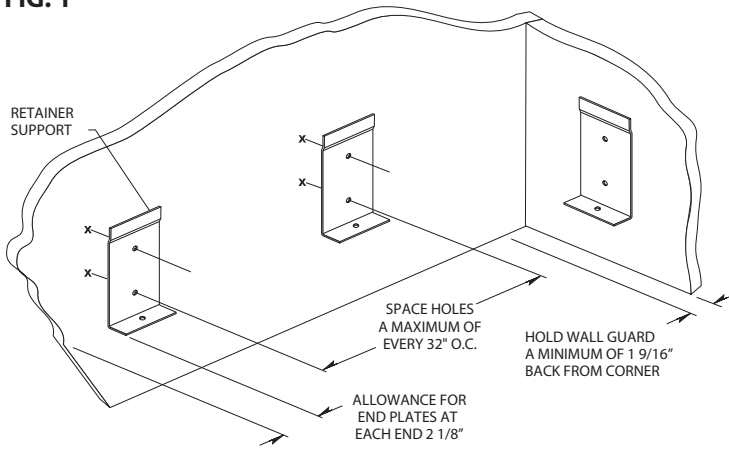

1. Determine height of wall guard. Deduct 3/16" and snap chalk line. Position top edge of retainer support against chalk line. Transfer mounting holes to wall. SEE FIG. 1

FIG. 2

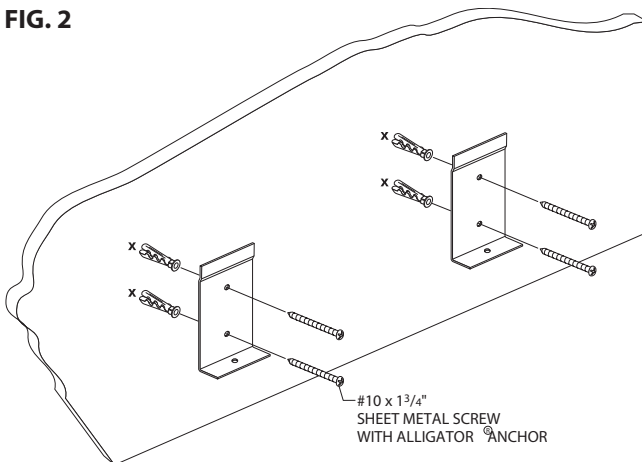

2. Drill each marked hole with a 1/4"[6mm] drill bit and position alligator anchors into holes. Mount retainer supports on wall and tighten screws to secure. SEE FIG. 2

IPC® Door + Wall Protection

inpro.com • 800.222.5556 • 262.679.9010

World Headquarters S80 W18766 Apollo Drive, Muskego, WI 53150 USA

Installation Hotline: 866.394.6776

inpro®

Installation Instructions

30SS and 31SS Stainless Steel Wall Guard

Please read all instructions before installing wallguard.

FIG. 3

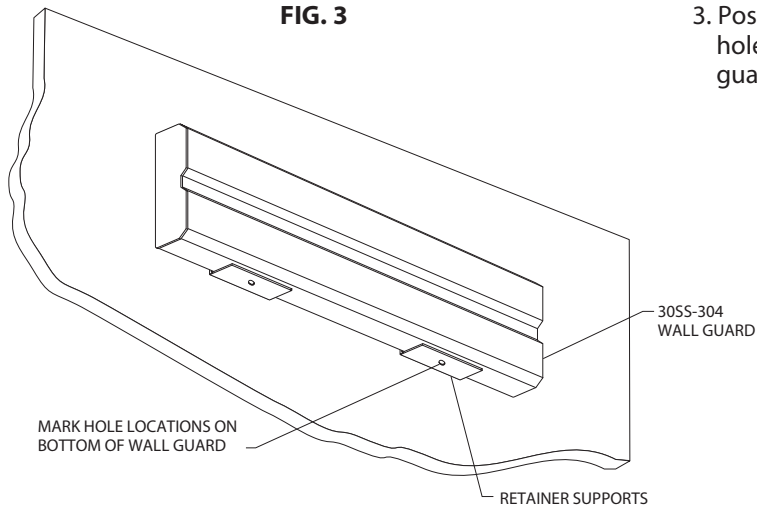

3. Position wall guard on the retainer supports. Transfer hole locations on the bottom of the support to the wall guard. Drill $9/64$ " holes at each mark. SEE FIG. 3

FIG. 4

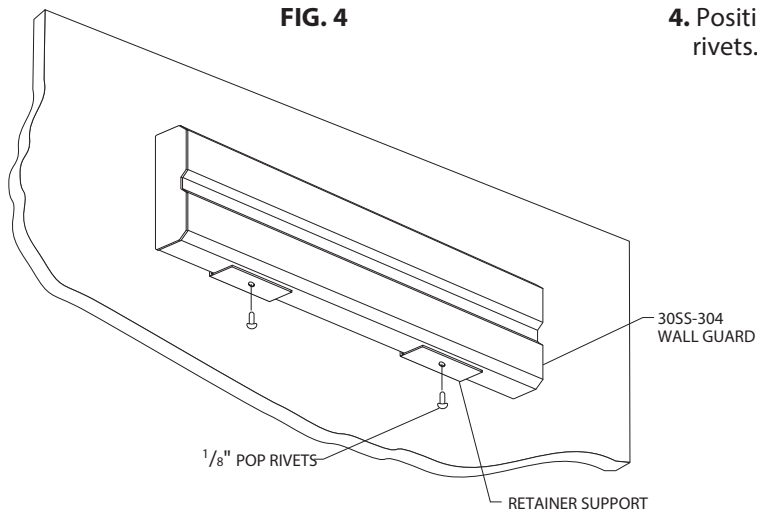

4. Position wall guard on support and secure with $1/8$ " pop rivets. SEE FIG. 4

IPC® Door + Wall Protection

inpro.com • 800.222.5556 • 262.679.9010

World Headquarters S80 W18766 Apollo Drive, Muskego, WI 53150 USA

Installation Hotline: 866.394.6776

inpro®