

Installation Instructions

Joint System: 353/353C/355/355C-A07/A09

Note: Verify that the structural gap is in conformance with submittal data before beginning installation. If this is a Fire Rated Assembly, install the fire barrier before the Architectural Joint System. Refer to the fire barrier instructions for specific system installation. Reference project specific details before installation. Completely read all instructions before installing.

Fig. 1

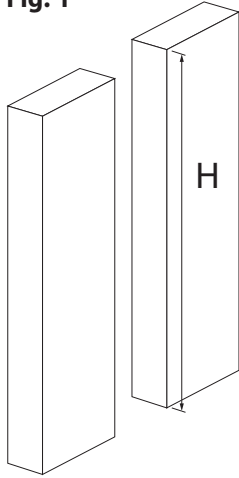

Fig. 1 - Layout

1. Before installation measure the total height of the expansion joint. Measure from finished floor to ceiling.
2. If installing system on both ceiling and wall, begin installation on ceiling first.

Fig. 2 - Pan Prep

3. Locate jamb rails, and appropriate cover pan. Using the height of the entire run, subtract 3" [75mm] and cut components to length.

Note: For wall pans, in areas of 8' [2.4m] or 9' [2.7m] height runs, remove equal lengths from both top and bottom of the pan to ensure magnets are evenly spaced along the height of the wall.

4. Record the measurements from one end of the pan to the center of the first magnetic plate, and the on center distance between the remaining plates.

Fig. 2

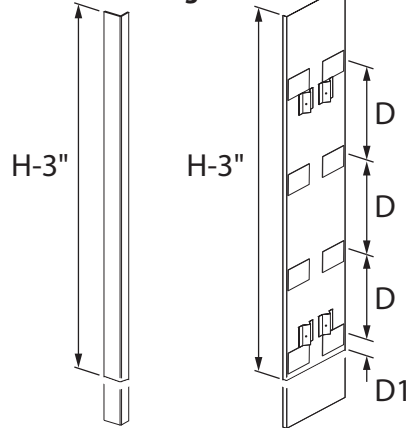
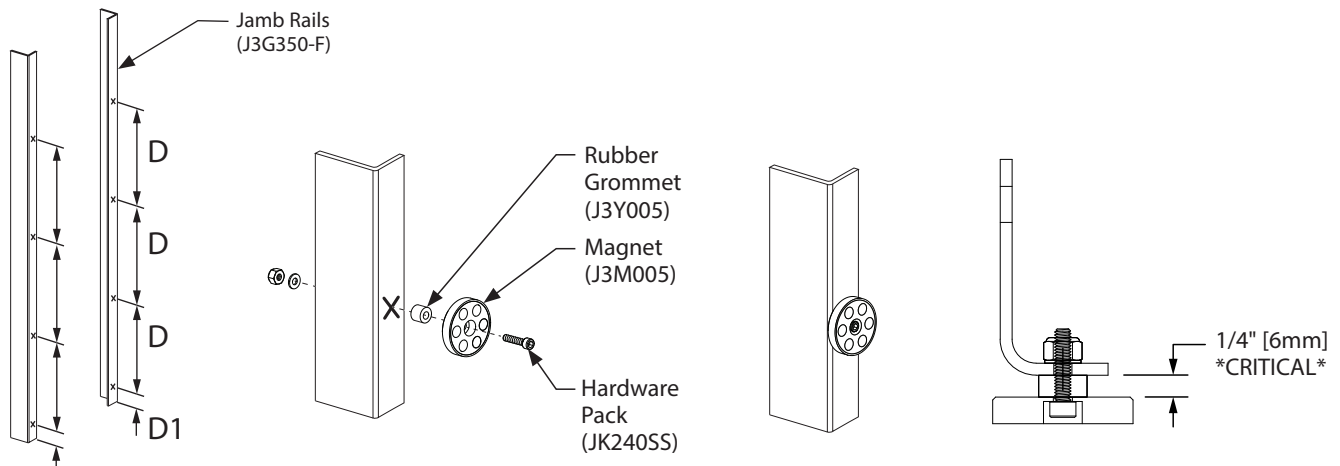

Fig. 3 - Magnet Alignment With Pan Plates

5. Transfer measurements from step 4 to the short leg on the jamb rails. Ensure the rails are oriented with a left and right orientation as shown in Fig 3.
6. If a pre-fabricated hole exists within 1" [25mm] of the mark from step 5, use that for fastening the magnet to the jamb rail. If not, drill a mounting hole with a 7/32" [5.5mm] bit. Fasten the magnet to the jamb rail with hardware pack JK240SS, (#8x3/4" SS socket head screw, SS washer and #8 SS lock nut) making sure to sandwich J3Y005, rubber grommet, inbetween the magnet and the jamb rail. DO NOT TIGHTEN ALL THE WAY.

Fig. 3



IPC.3107/REV.5

JOINTMASTER® Expansion Joint Systems

inpro.com • 800.222.5556 • 262.679.9010

World Headquarters S80 W18766 Apollo Drive, Muskego, WI 53150 USA

Installation Hotline: 866.394.6776

inpro®

Installation Instructions

Joint System: 353/353C/355/355C-A07/A09

Fig. 5

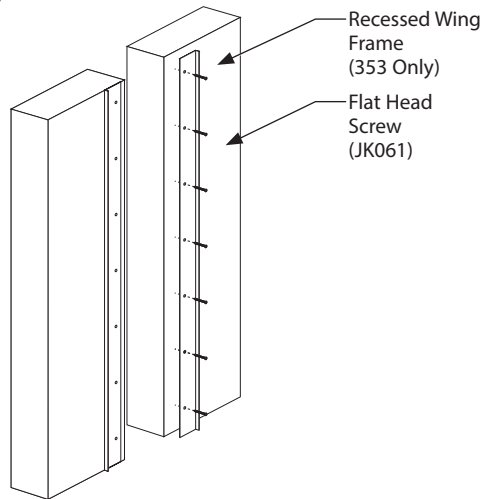

Fig. 5 - Locating Recessed Wings

(For 353 recessed system with side wings only)

8. Measure the width of the pan, and install recessed wing frames so they allow a 1 1/4" [31mm] distance from the edge of the pan to the inside face of the recessed wing.

NOTE: It is critical to confirm dimension against supplied details, before installation of wings.

9. Fasten recessed wings using the supplied JK061, #8 x 2 [M4x50] flat head sheet metal screws.

Fig. 6 - Locating Jamb Rails

10. Place the jamb rails into the joint opening.

11. Using a straight edge or the supplied extra ferrous metal plate, ensure the top and bottom magnets extend slight past the face of the recessed wings or wall face (not farther than 1/16" [1.5mm]). Adjust each magnets as needed so all align equally. (See Fig 7a)

TIP: Mark the slotted hole locations on the inside walls and pre-drill using a 1/8" [3mm] drill bit. To prevent the self-drilling fastener from wandering from desired location.

Fig. 6

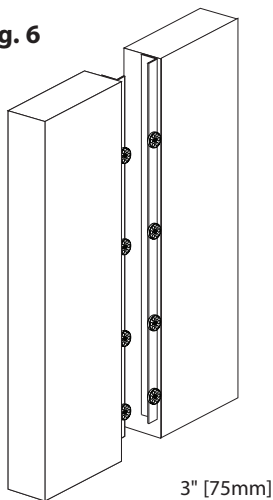

Fig. 6a

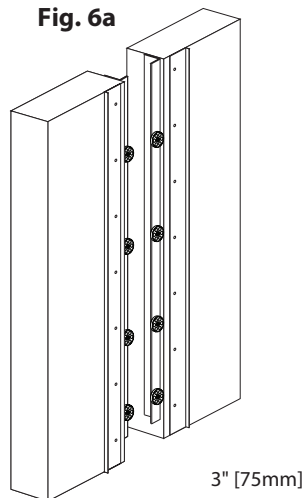

Fig. 7 - Installing Jamb Rails

12. Fasten the jamb rails using the supplied JK221, #12 x 2 1/2" [M5x65] hex head sheet metal screws, and JK150 spherical washers. Slotted holes allow for precession locating of jamb rails and attached magnets. Spherical washers assist with squaring of magnets to the cover pan when wall jambs are not exactly a 90° angle.

TIP: After fastening the jamb rails, double check to make sure all magnets are positioned correctly as stated in step 11. (See Fig 7a)

Fig. 7

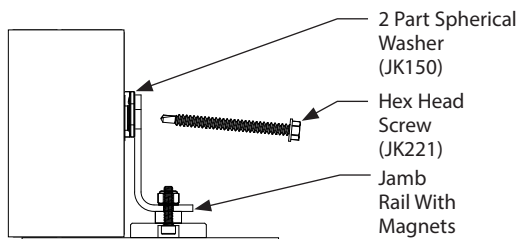
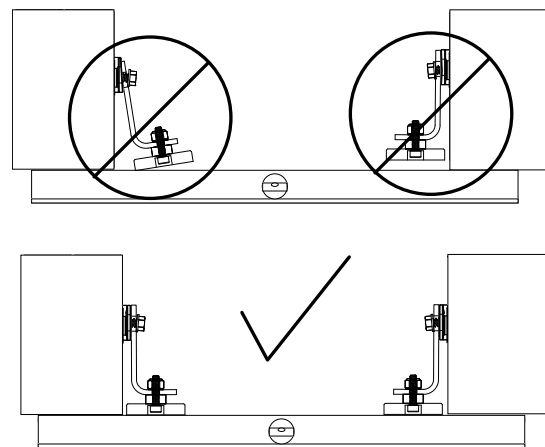

Fig. 7a



Installation Instructions

Joint System: 353/353C/355/355C-A07/A09

Fig. 8

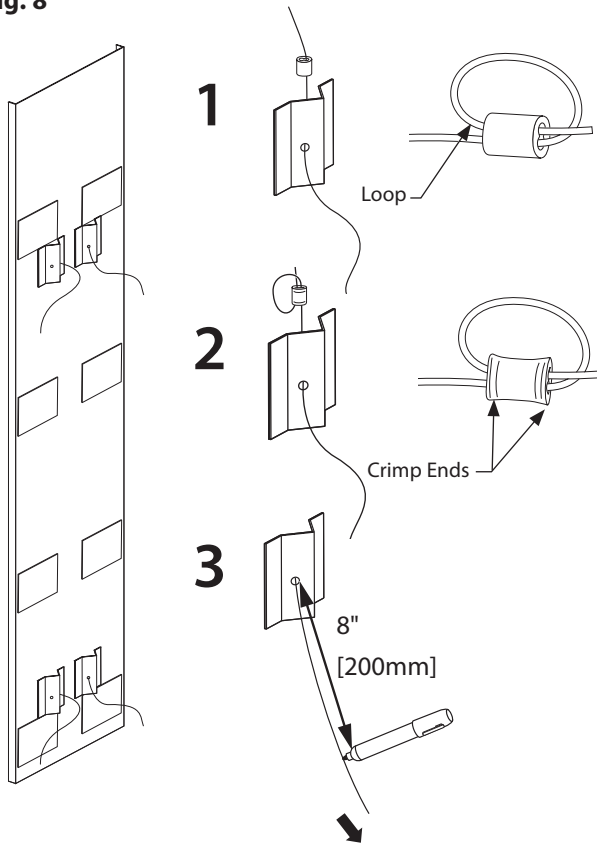

Fig. 8 - Prepping Arrest Cables

13. Secure the stainless steel arrest cables so they are installed through the inside hole on each triangular pop-up bracket.

a. Slide supplied stainless steel cable through pre-drilled hole. Slide supplied crimp onto cable.

b. Loop stainless steel cable around crimp, and slide through other side of crimp. Using a pair of vicegrips crush both ends of the crimp on to the cable.

NOTE: DO NOT CRUSH MIDDLE OF CRIMP

c. Pull opposite end of cable tight, and measure 8" [200mm] from the hole on the bracket down the length of cable. Mark cable using a permanent marker.

Fig. 9 - Installing Pan Arrest Cables to Jamb

14. Bring pan assembly to the expansion joint opening, and secure the arrest cables to the jamb rail through one of the pre-drilled holes.

15. Slide a provided crimp on to the free end of the stainless steel cable. Insert the free end of the cable through the front face of the jamb rail and loop the cable back into the crimp.

16. Slide the loop so the marked location is sitting in the pre-drilled hole (see Fig. 9a)

17. Crush crimps using vice grips per steps above

NOTE: It is important to ensure the holes on each opposing side are in line. If they are not, use a 1/8" [3mm] drill bit to make a new hole in the desired location.

18. Repeat process for all cable locations.

Fig. 9

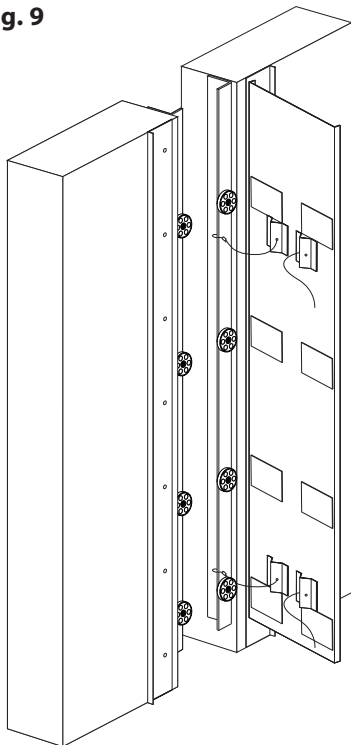
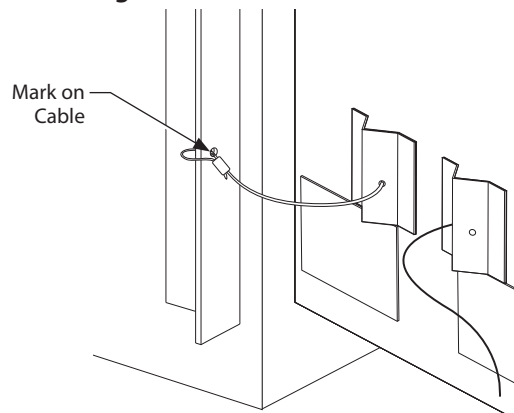

Fig. 9a



JOINTMASTER® Expansion Joint Systems

inpro.com • 800.222.5556 • 262.679.9010

World Headquarters S80 W18766 Apollo Drive, Muskego, WI 53150 USA

Installation Hotline: 866.394.6776

inpro®

Installation Instructions

Joint System: 353/353C/355/355C-A07/A09

Fig. 10

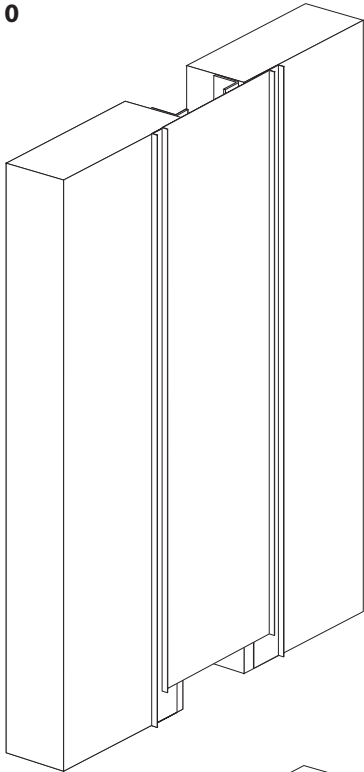

Fig. 10 - Attaching Pan to Wall

19. Center the cover pan while holding it away from the expansion joint. Then allow magnets to catch the pan as you move it closer.

Installing In-fill Materials

20. Using a wire brush, or a belt/palm sander, roughen the inside surface of the pan on all faces that will receive the infill.

- **Gypsum / Plaster / Cement Board:** To be installed with heavy duty construction adhesives or epoxies. Verify best solution with adhesive manufacturer and/or construction consultant specializing in your finishes specific traits.

- **Ceramic Tile / Solid Surface:** To be installed using 100% silicone adhesive appropriate for bonding to metal to allow for thermal expansion & contraction. Place 3/4" [19mm] wide dabs at 8" [200mm] on center in a grid pattern throughout the pan.

21. Allow infill materials to cure a minimum of 24 hours prior to installation.

Fig. 10a

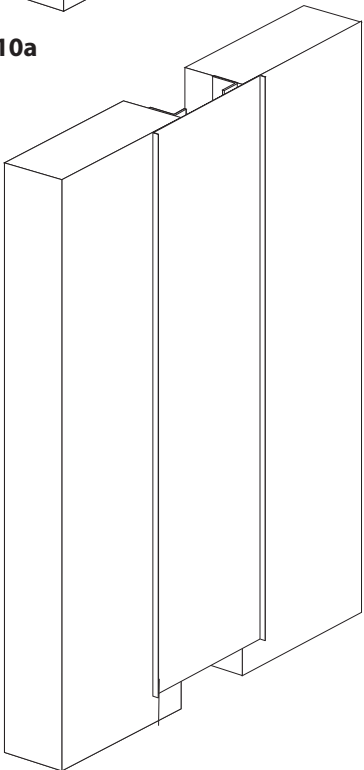

Installation Instructions

Joint System: 353/353C/355/355C-A07/A09

Fig. 11

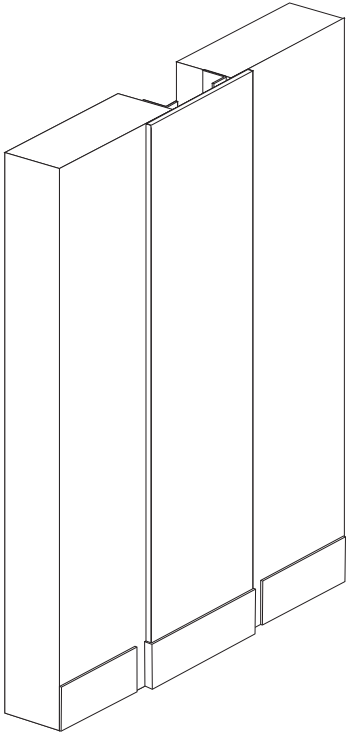

355 System: Installing Wall Base Materials

21. Install wall base terminating 1 1/4" [31mm] from each end of the cover plate. Never run the wall base thicker than 1/8" [3mm] flush to the sides of the pan.
22. Apply a bead of construction adhesive along the bottom edge of the infill finish. Press the wall base against the adhesive and pin nail or use painters tape to hold wall base until it cures.

NOTE: If installing flexible wall base, adhering a 1/2" [12mm] thick, 2" [51mm] tall piece of plywood to the back side of the wall base, flush with the bottom edge to the back side of the wall base.

Fig. 11a

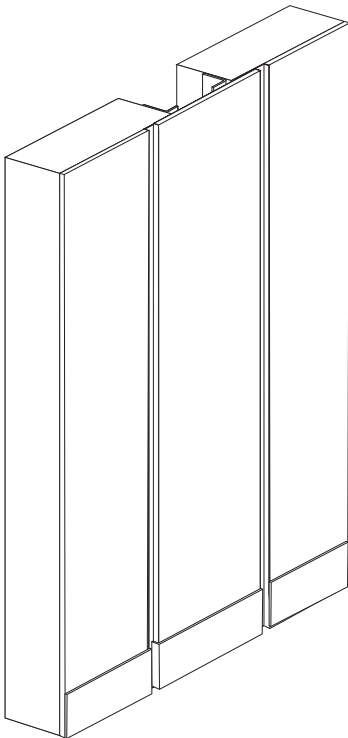

353 System: Installing Wall Base Materials

21. Install wall base flush terminating at each end of the recessed frames. Never run the wall base over the gap of the recessed wing.
22. Apply a bead of construction adhesive along the bottom edge of the infill finish. Press the wall base against the adhesive and pin nail or use painters tape to hold wall base until it cures.

NOTE: If installing flexible wall base, adhering a 1/2" [12mm] thick, 2" [51mm] tall piece of plywood to the back side of the wall base, flush with the bottom edge to the back side of the wall base.