

353C-A07-150

JOINT WIDTH		MOVEMENT			
		MINIMUM		MAXIMUM	
US	mm	US	mm	US	mm
6"	152	2 3/4"	70	12"	305

FINISH: CLEAR ANODIZED
PROJECT:
CUSTOMER:
LOCATION:

APPLICATION -
WALL/WALL CONCEALED PAN EXPANSION JOINT SYSTEM- ACCEPTS
VARIETY OF WALL FINISHES

DATE:	9/4/18
SCALE:	1:4
DOC:	CADJM.232/R3



For More Information Visit: Inprocorp.com

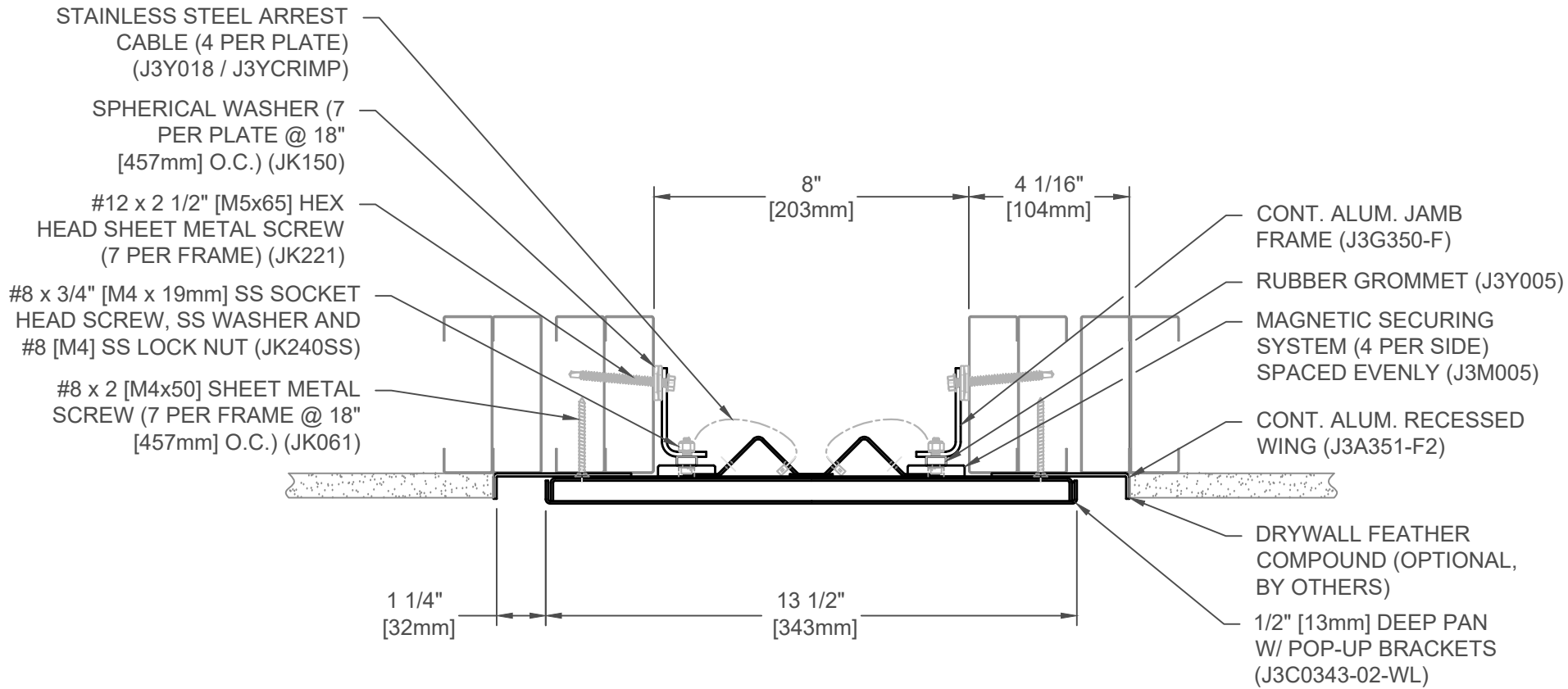

353C-A07-200

JOINT WIDTH		MOVEMENT			
		MINIMUM		MAXIMUM	
US	mm	US	mm	US	mm
8"	203	2 3/4"	70	16"	406

FINISH: CLEAR ANODIZED
PROJECT:
CUSTOMER:
LOCATION:

APPLICATION -
WALL/WALL CONCEALED PAN EXPANSION JOINT SYSTEM- ACCEPTS
VARIETY OF WALL FINISHES

DATE:	9/4/18
SCALE:	1:4
DOC:	CADJM.232/R3



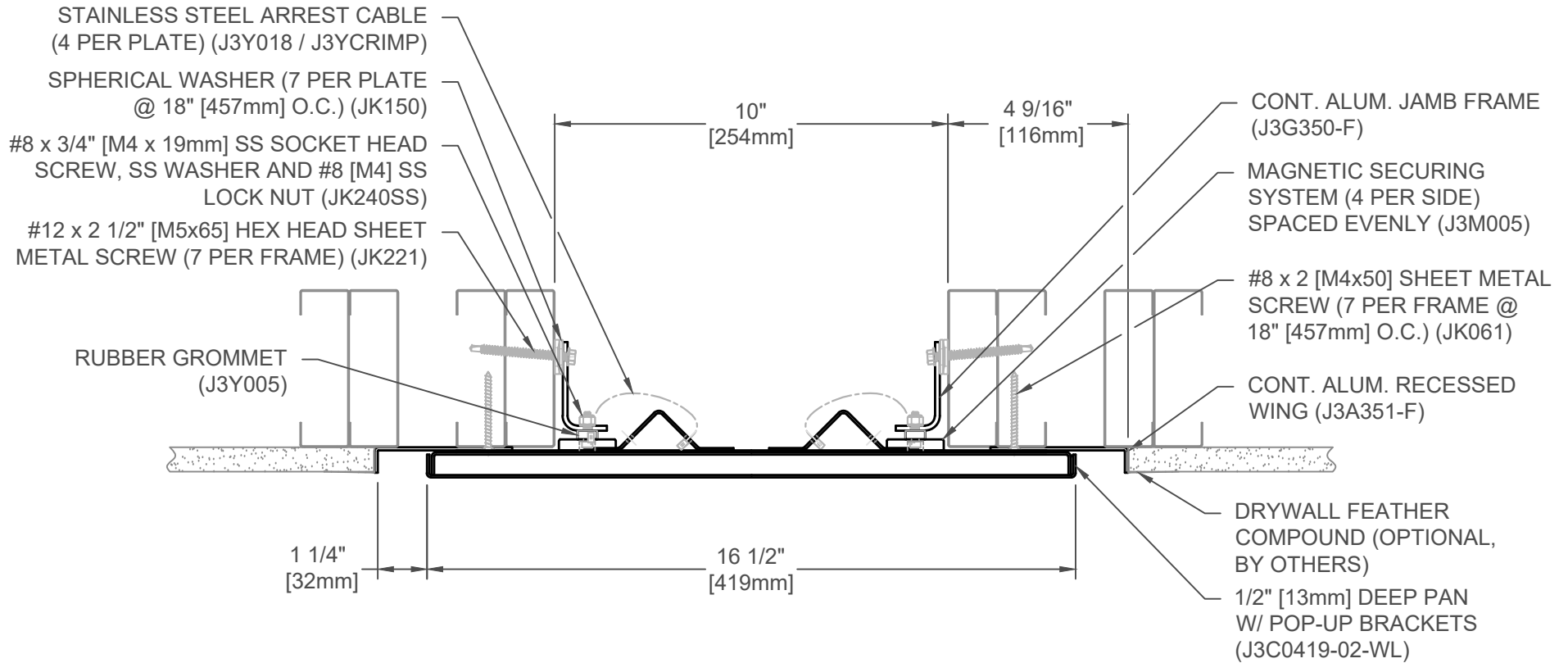

353C-A07-250

JOINT WIDTH		MOVEMENT			
		MINIMUM		MAXIMUM	
US	mm	US	mm	US	mm
10"	254	2 3/4"	70	20"	508

FINISH: CLEAR ANODIZED
PROJECT:
CUSTOMER:
LOCATION:

APPLICATION -
WALL/WALL CONCEALED PAN EXPANSION JOINT SYSTEM- ACCEPTS
VARIETY OF WALL FINISHES

DATE:	9/4/18
SCALE:	1:4
DOC:	CADJM.232/R3



For More Information Visit: Inprocorp.com

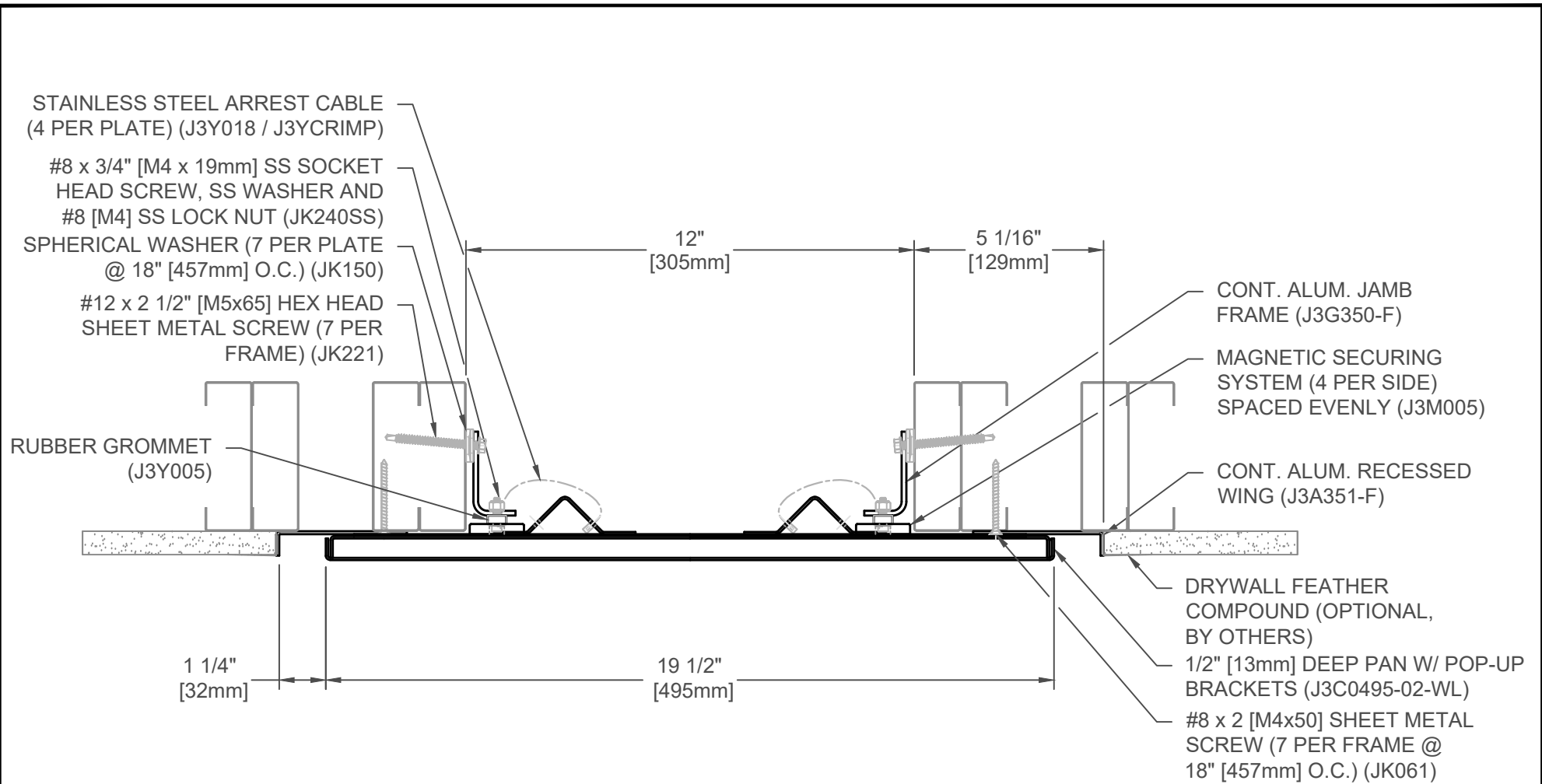

353C-A07-300

JOINT WIDTH		MOVEMENT			
		MINIMUM		MAXIMUM	
US	mm	US	mm	US	mm
12"	305	2 3/4"	70	24"	610

FINISH: CLEAR ANODIZED
PROJECT:
CUSTOMER:
LOCATION:

APPLICATION -
WALL/WALL CONCEALED PAN EXPANSION JOINT SYSTEM- ACCEPTS
VARIETY OF WALL FINISHES

DATE:	9/4/18
SCALE:	1:4
DOC:	CADJM.232/R3

inpro.
For More Information Visit: Inprocorp.com

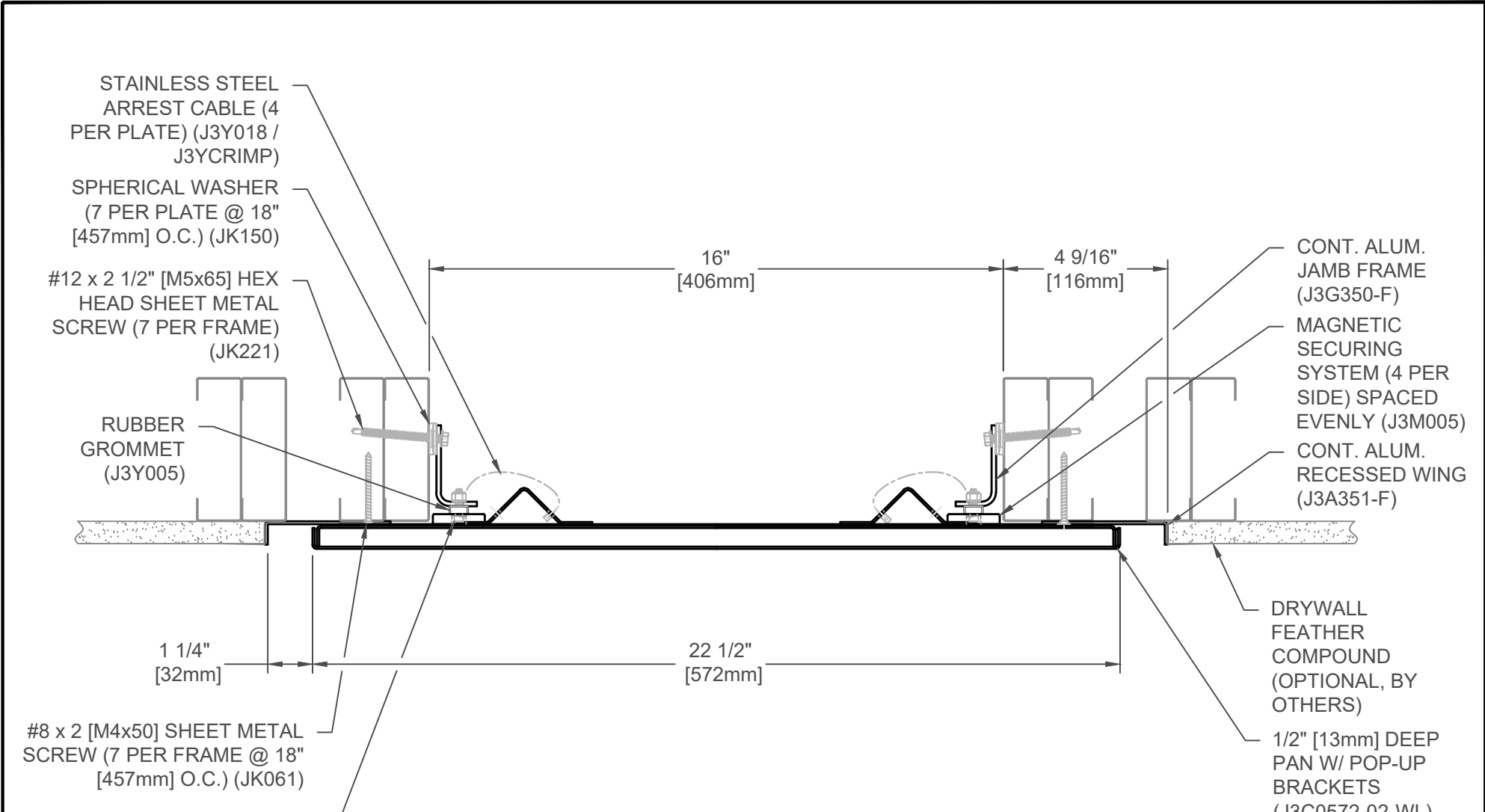

353C-A07-400

JOINT WIDTH		MOVEMENT			
		MINIMUM		MAXIMUM	
US	mm	US	mm	US	mm
16"	406	2 3/4"	70	32"	813

FINISH: CLEAR ANODIZED
PROJECT:
CUSTOMER:
LOCATION:

APPLICATION -
WALL/WALL CONCEALED PAN EXPANSION JOINT SYSTEM- ACCEPTS
VARIETY OF WALL FINISHES

DATE:	9/4/18
SCALE:	1:4
DOC:	CADJM.232/R3



For More Information Visit: Inprocorp.com

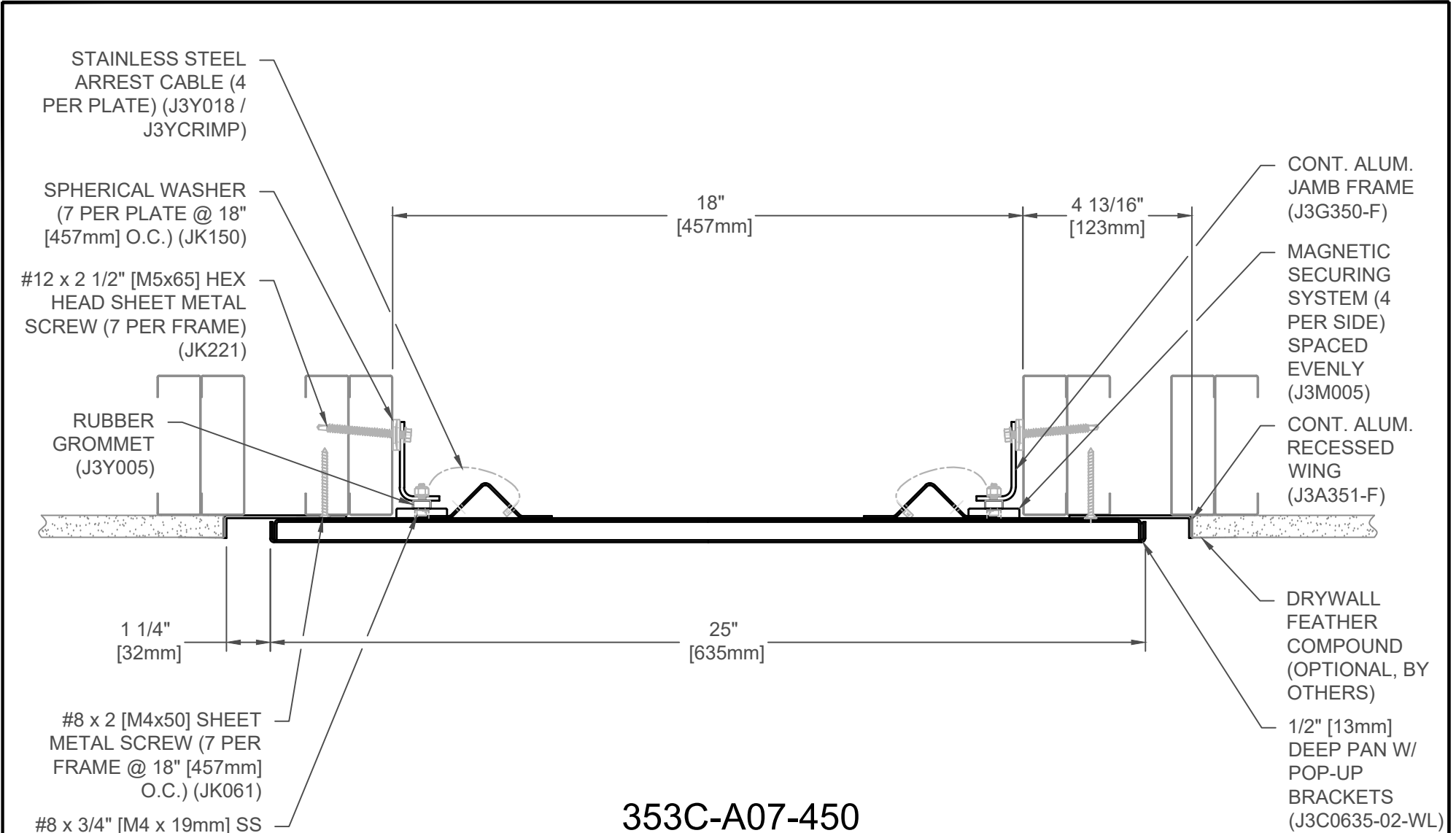

353C-A07-450

JOINT WIDTH		MOVEMENT			
		MINIMUM		MAXIMUM	
US	mm	US	mm	US	mm
18"	457	2 3/4"	70	36"	914

FINISH: CLEAR ANODIZED
PROJECT:
CUSTOMER:
LOCATION:

APPLICATION -
WALL/WALL CONCEALED PAN EXPANSION JOINT SYSTEM- ACCEPTS
VARIETY OF WALL FINISHES

DATE:	9/4/18
SCALE:	1:4
DOC:	CADJM.232/R3

inpro.

For More Information Visit: Inprocorp.com

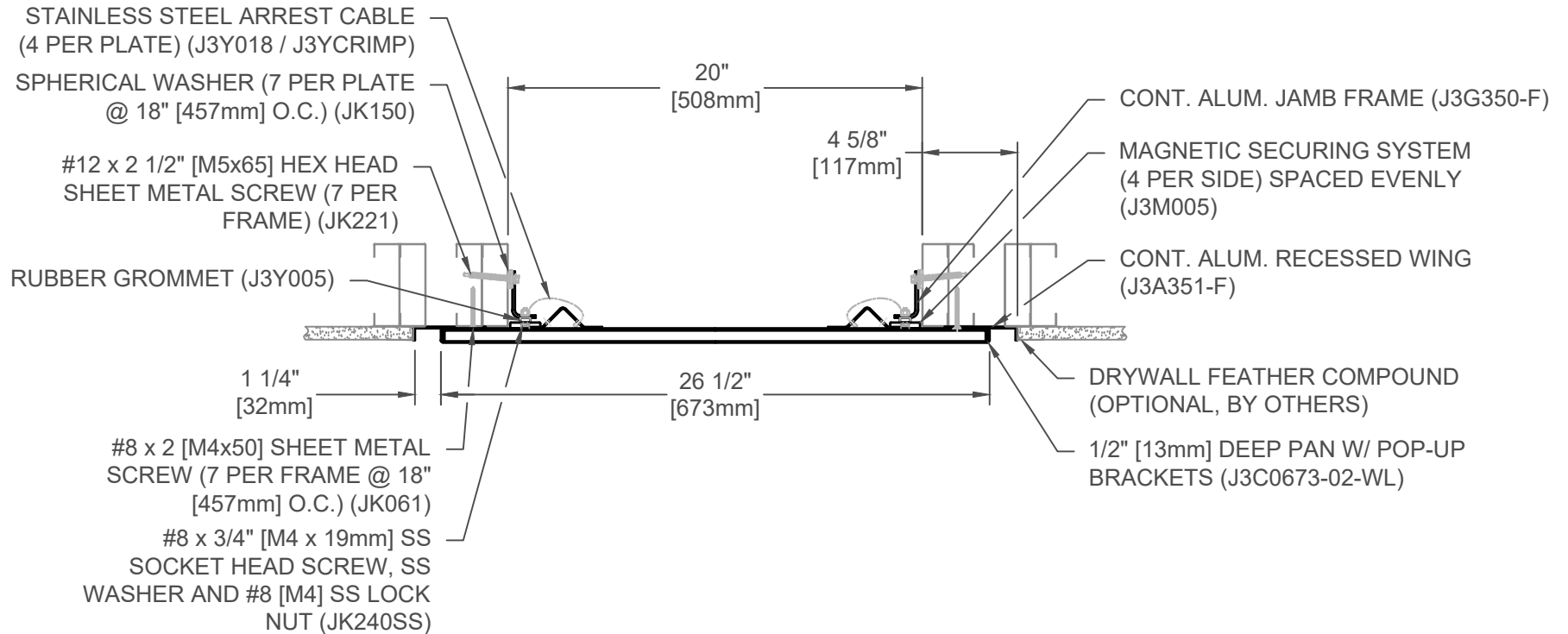

353C-A07-500

JOINT WIDTH		MOVEMENT			
		MINIMUM		MAXIMUM	
US	mm	US	mm	US	mm
20"	508	2 3/4"	70	40"	1016

FINISH: CLEAR ANODIZED
PROJECT:
CUSTOMER:
LOCATION:

APPLICATION -
WALL/WALL CONCEALED PAN EXPANSION JOINT SYSTEM- ACCEPTS
VARIETY OF WALL FINISHES

DATE:	9/4/18
SCALE:	1:8
DOC:	CADJM.232/R3



For More Information Visit: Inprocorp.com

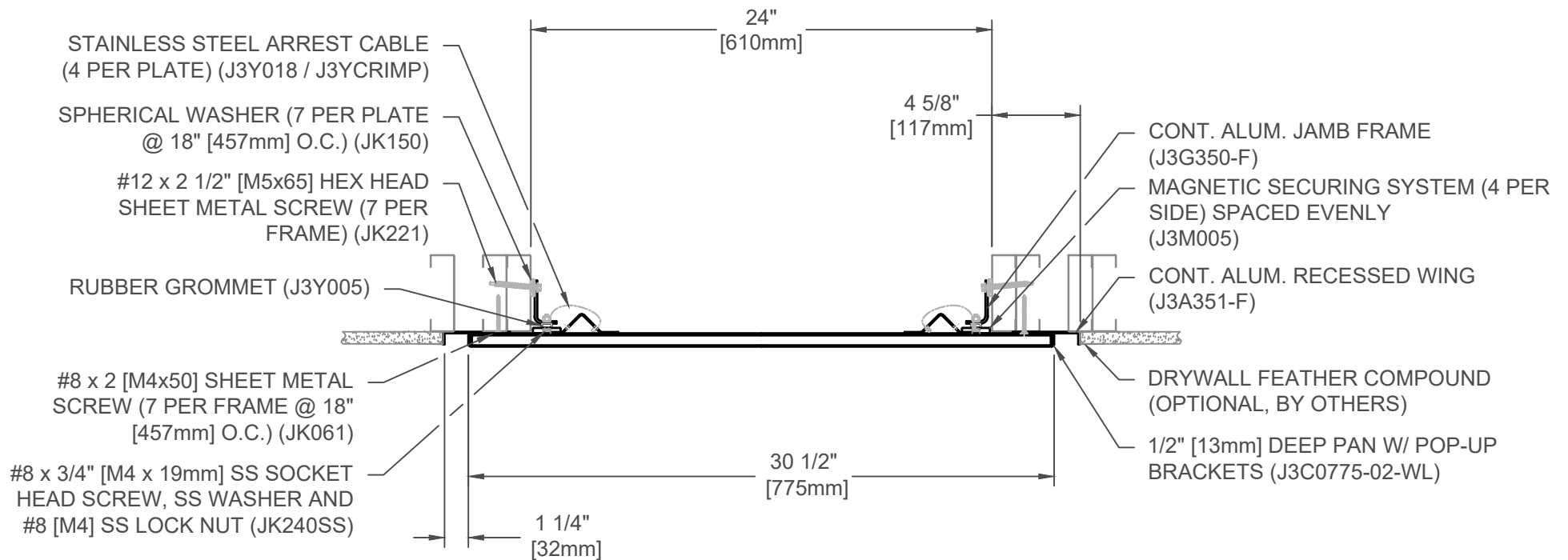

353C-A07-600

JOINT WIDTH		MOVEMENT			
		MINIMUM		MAXIMUM	
US	mm	US	mm	US	mm
24"	610	2 3/4"	70	48"	1219

FINISH: CLEAR ANODIZED
PROJECT:
CUSTOMER:
LOCATION:

APPLICATION -
WALL/WALL CONCEALED PAN EXPANSION JOINT SYSTEM- ACCEPTS
VARIETY OF WALL FINISHES

DATE:	9/4/18
SCALE:	1:8
DOC:	CADJM.232/R3



For More Information Visit: Inprocorp.com