

491-A09-050

JOINT WIDTH		MOVEMENT ±			
		HORIZONTAL		VERTICAL	
US	mm	US	mm	US	mm
2"	51	1/2"	13	1/2"	13

FINISH: CLEAR ANODIZED

PROJECT:

CUSTOMER:

LOCATION:

APPLICATION-
CENTERING BAR SYSTEM
SURFACE MOUNT FRAME WALL/CORNER, WALL/CEILING CONDITION

DATE: 9-30-05

SCALE: 1:2

DOC: CADJM.006/R4

inpro.

For More Information Visit: Inprocorp.com

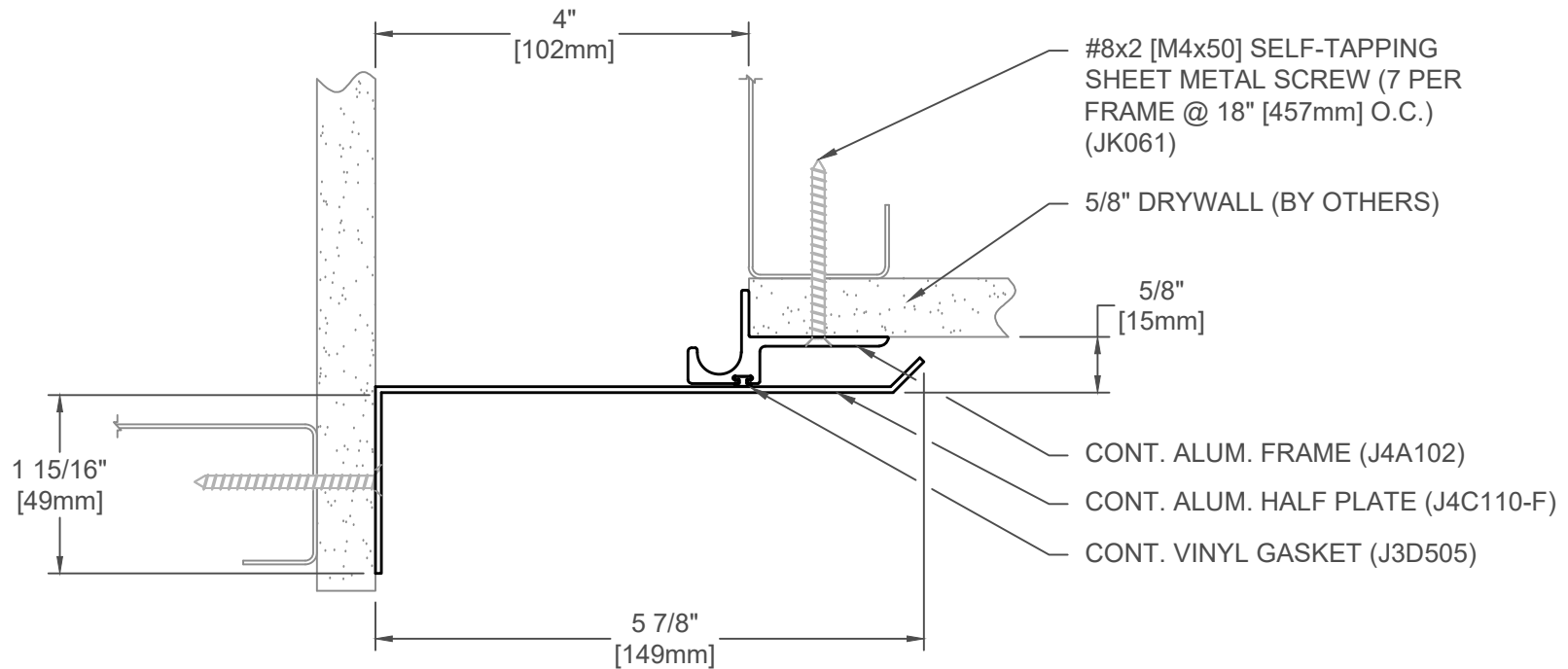

491-A09-100

JOINT WIDTH		MOVEMENT ±			
		HORIZONTAL		VERTICAL	
US	mm	US	mm	US	mm
4"	102	1"	25	1"	25

FINISH: CLEAR ANODIZED

PROJECT:

CUSTOMER:

LOCATION:

APPLICATION-
CENTERING BAR SYSTEM
SURFACE MOUNT FRAME WALL/CORNER, WALL/CEILING CONDITION

DATE: 9-30-05

SCALE: 1:2

DOC: CADJM.006/R4

inpro.

For More Information Visit: Inprocorp.com

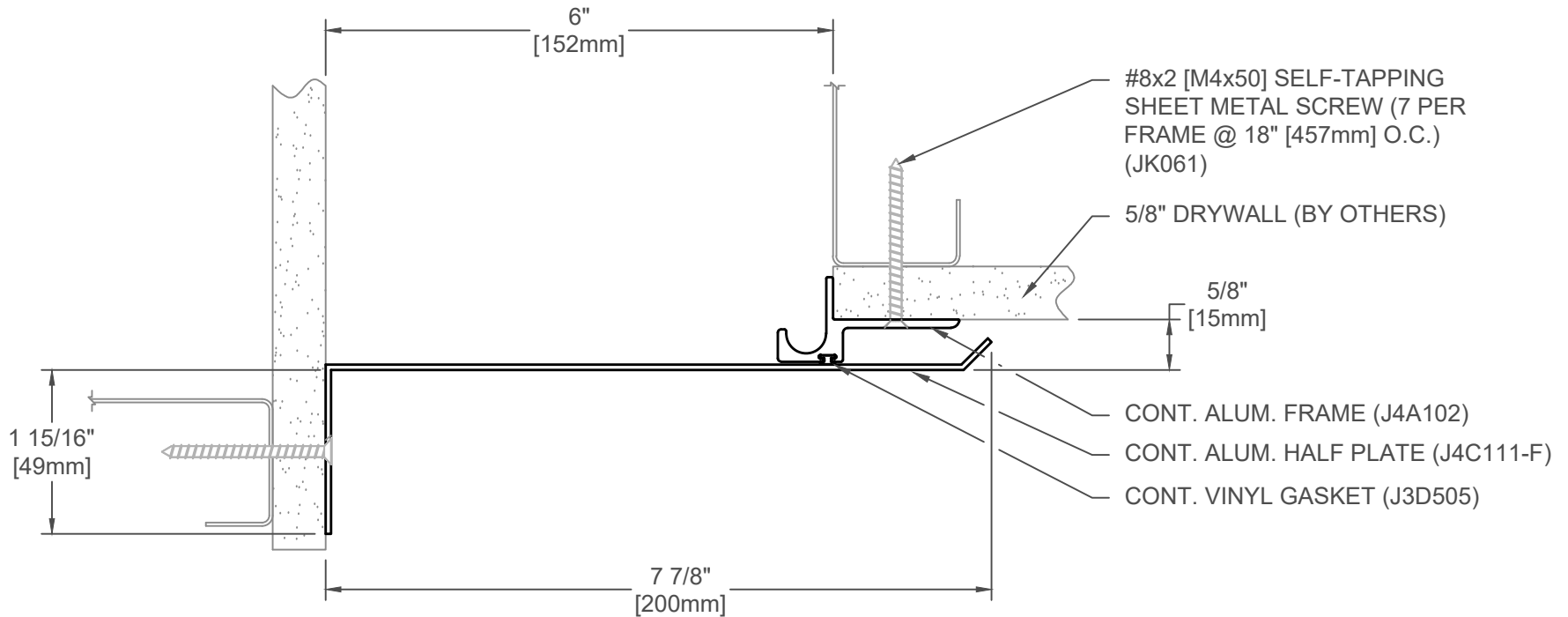

491-A09-150

JOINT WIDTH		MOVEMENT ±			
		HORIZONTAL		VERTICAL	
US	mm	US	mm	US	mm
6"	152	1-1/2"	38	1-1/2"	38

FINISH: CLEAR ANODIZED

PROJECT:

CUSTOMER:

LOCATION:

APPLICATION-
CENTERING BAR SYSTEM
SURFACE MOUNT FRAME WALL/CORNER, WALL/CEILING CONDITION

DATE: 9-30-05

SCALE: 1:2

DOC: CADJM.006/R4

inpro.

For More Information Visit: Inprocorp.com

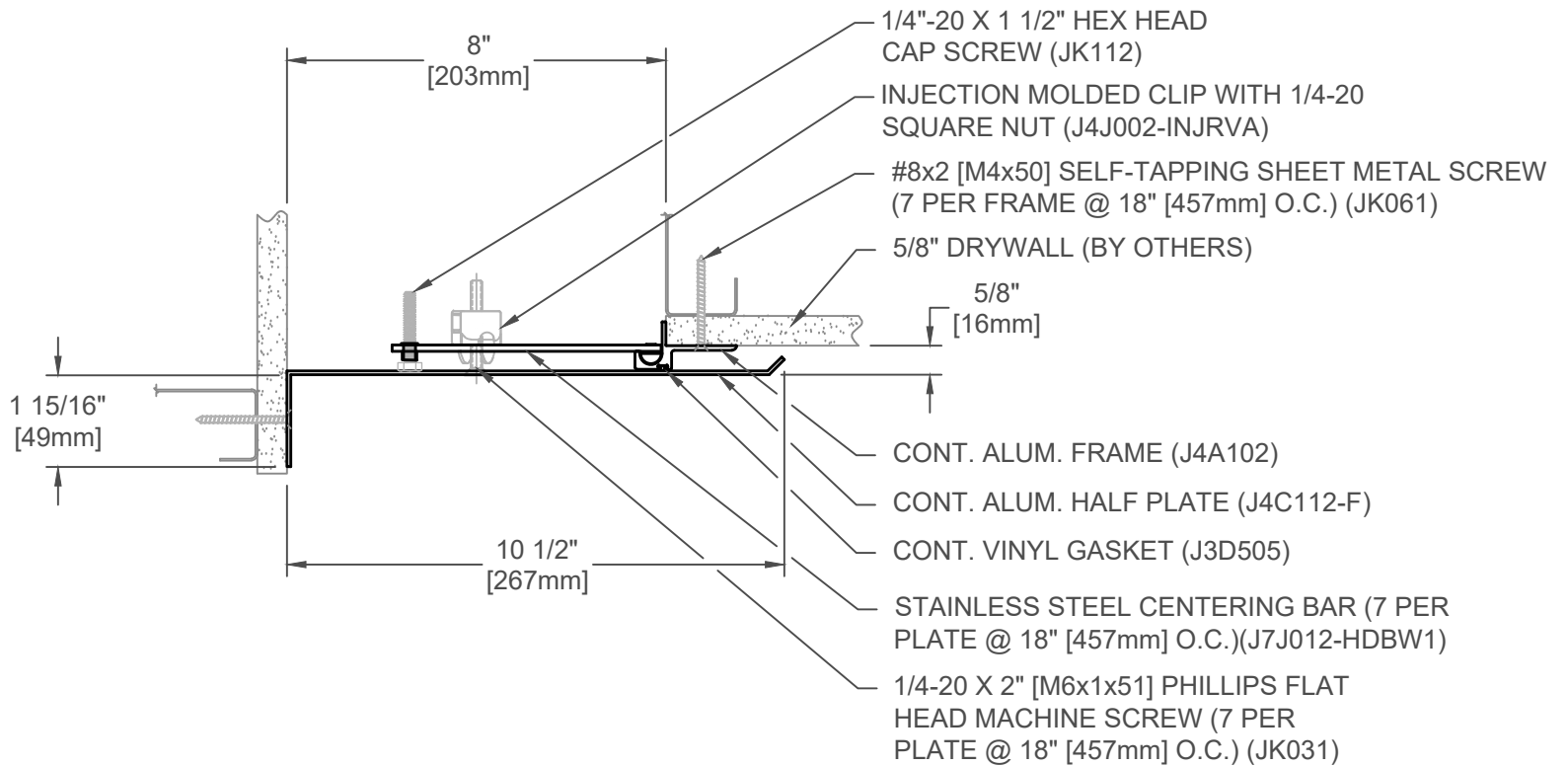

491-A09-200

JOINT WIDTH		MOVEMENT ±			
		HORIZONTAL		VERTICAL	
US	mm	US	mm	US	mm
8"	203	2"	51	2"	51

FINISH: CLEAR ANODIZED

PROJECT:

CUSTOMER:

LOCATION:

APPLICATION-
CENTERING BAR SYSTEM
-SURFACE MOUNT FRAME WALL/CORNER, WALL/CEILING CONDITION

DATE: 9-7-05

SCALE: 1:4

DOC: CADJM.006/R4

inpro.

For More Information Visit: Inprocorp.com

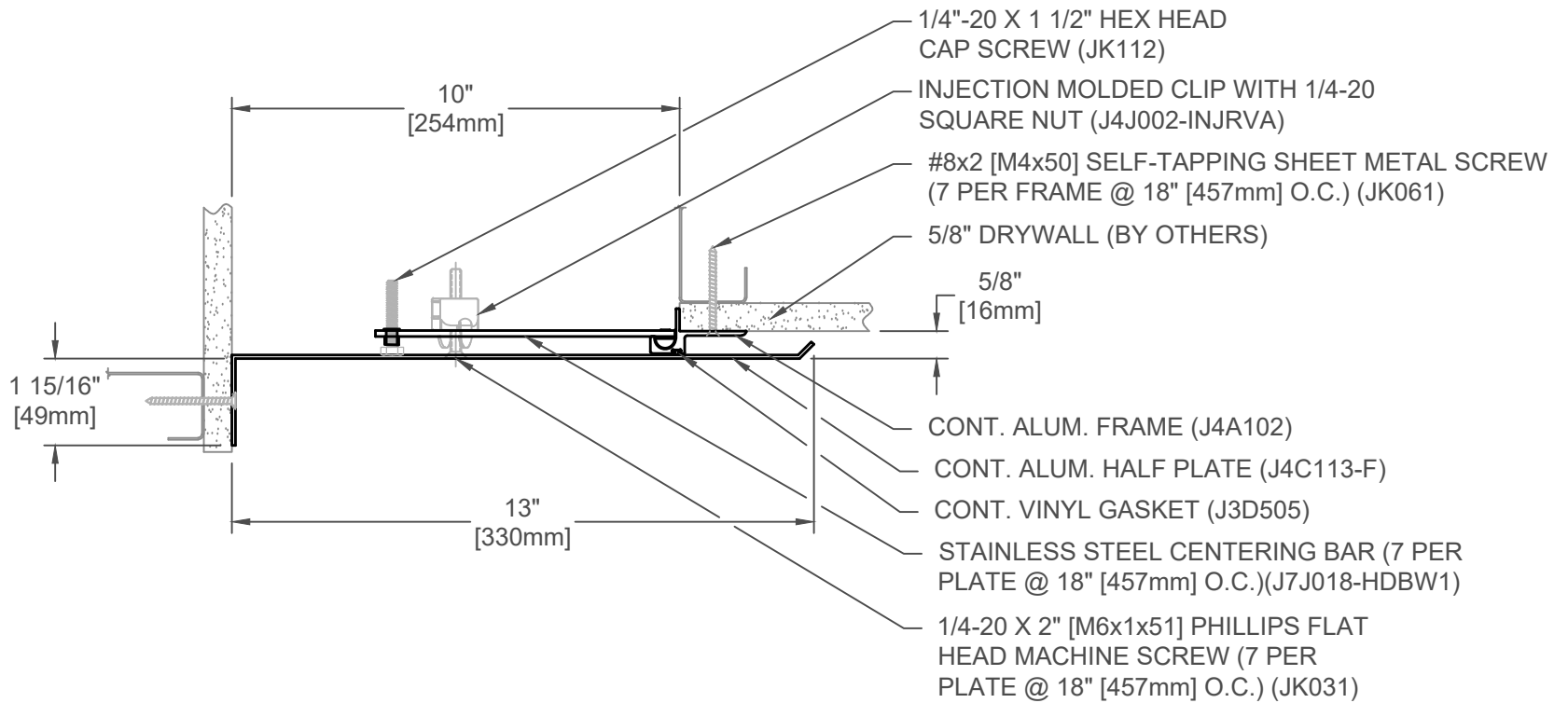

491-A09-250

JOINT WIDTH		MOVEMENT ±			
		HORIZONTAL		VERTICAL	
US	mm	US	mm	US	mm
10"	254	2-1/2"	64	2-1/2"	64

FINISH: CLEAR ANODIZED
PROJECT:
CUSTOMER:
LOCATION:

APPLICATION-
 CENTERING BAR SYSTEM
 -SURFACE MOUNT FRAME
 WALL/CORNER, WALL/CEILING
 CONDITION

DATE:	9-7-05
SCALE:	1:4
DOC:	CADJM.006/R4

inpro.
 For More Information Visit: Inprocorp.com

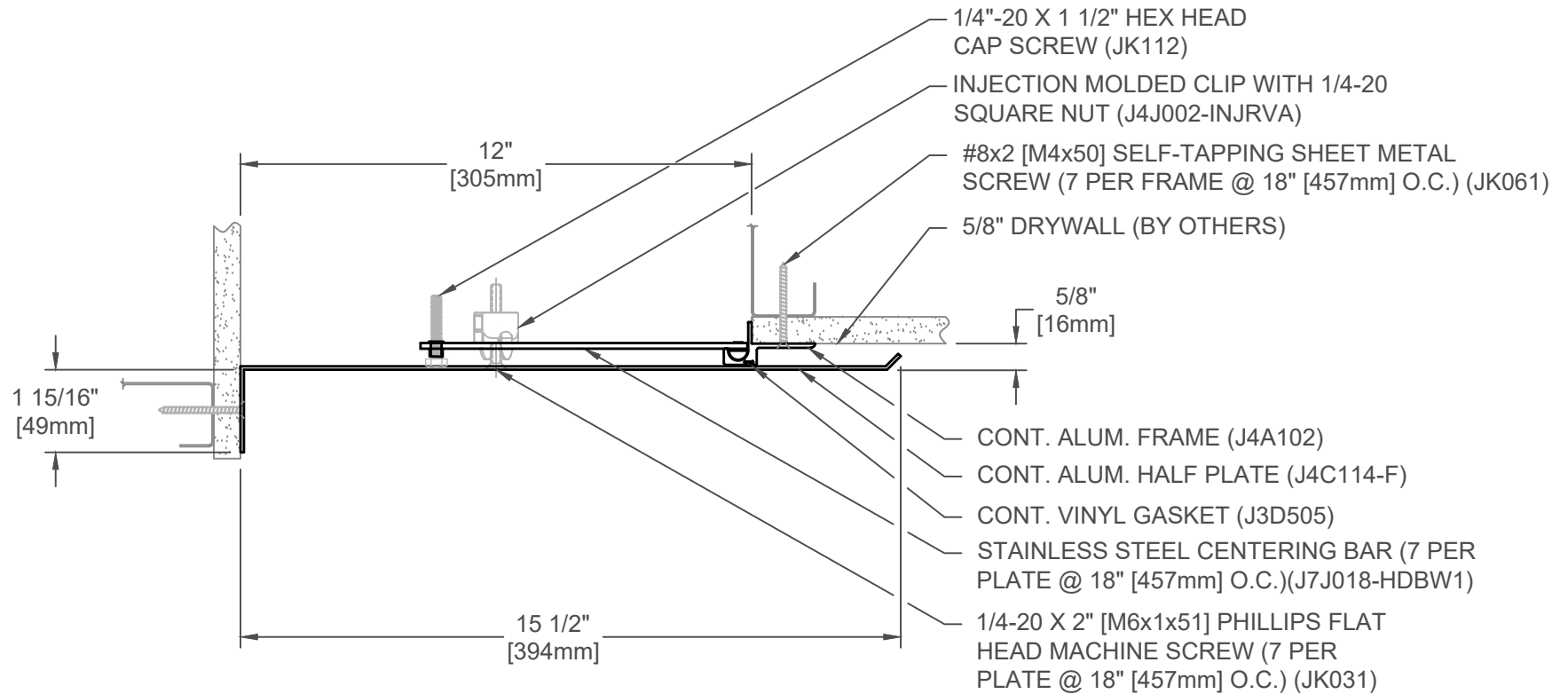

491-A09-300

JOINT WIDTH		MOVEMENT ±			
		HORIZONTAL		VERTICAL	
US	mm	US	mm	US	mm
12"	305	3"	76	3"	76

FINISH: CLEAR ANODIZED

PROJECT:

CUSTOMER:

LOCATION:

APPLICATION-
CENTERING BAR SYSTEM
-SURFACE MOUNT FRAME WALL/CORNER, WALL/CEILING CONDITION

DATE: 9-7-05

SCALE: 1:4

DOC: CADJM.006/R4

inpro.

For More Information Visit: Inprocorp.com