

Installation Instructions

700/700W/G2-700 WALL GUARD

Please read all instructions before installing wallguard.

Important

1. Acclimate materials 24 hrs before installation. Maintain temperature controlled environment after installation
2. Install in accordance with manufacturer's installation instructions. Failure to do so will void the warranty.

Installation tips

1. Cut covers up to 1/16" (1.6mm) longer to ensure a tight fit.
2. Lubricate blades when cutting aluminum to reduce burrs.

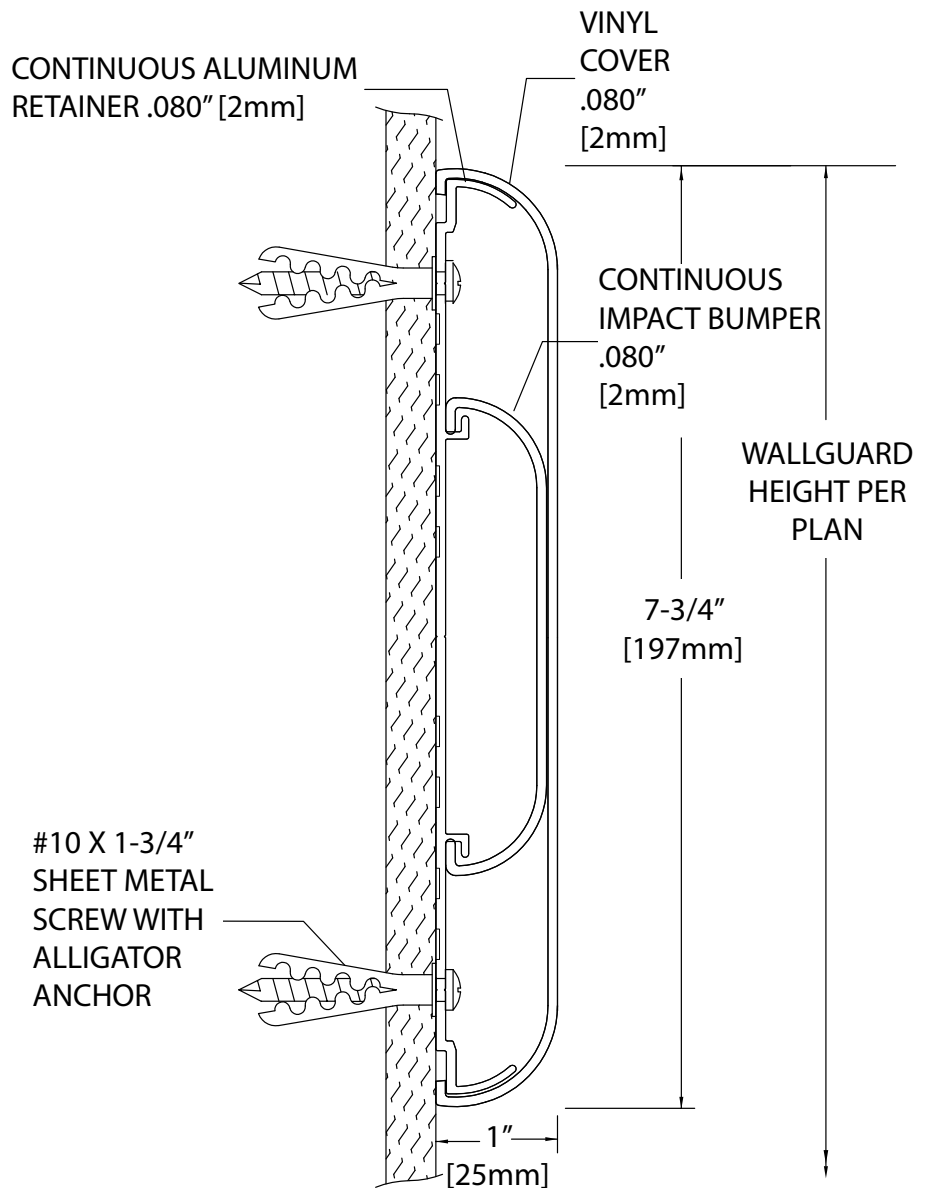

SECTION VIEW

Recommended tools

Safety Glasses, Tape Measure, Phillips bit for self drilling and sheet metal screws, Level, Power Drill, Drill Bits - 1/4" masonry (concrete/concrete block) bit, Power Miter Saw, 10" Blade with 60-80 Cabide Tipped Teeth

IPC.357_REV 12

IPC® Door + Wall Protection

inpro.com • 800.222.5556 • 262.679.9010

World Headquarters S80 W18766 Apollo Drive, Muskego, WI 53150 USA

Installation Hotline: 866.394.6776

inpro®

Installation Instructions

700/700W/G2-700 WALL GUARD

Please read all instructions before installing wallguard.

Components and fasteners



700V
COVER



700RVL
OPTIONAL
REVEAL



700B
IMPACT
BUMPER



706A
SPLICE



700A
CONTINUOUS
ALUMINUM
RETAINER

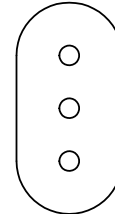

1601
OPTIONAL
OVAL
SPACER

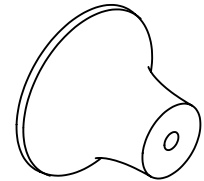

1001
MOUNTING
BRACKET

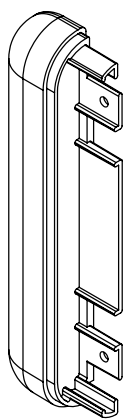

701
END
CAP

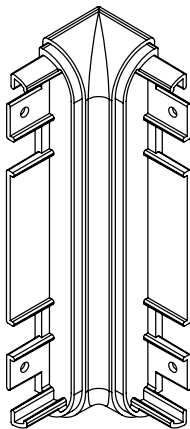

707
INSIDE
CORNER

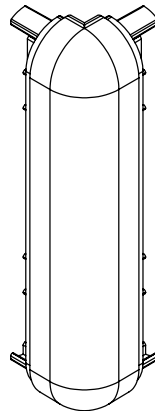

702
OUTSIDE
CORNER



#8 1-1/2" PHILLIPS INDENTED
HEX WASHER SELF-DRILLING
SCREW



#10 1-3/4" SHEET METAL
SCREW



ALLIGATOR
ANCHOR

Conditions	Specified Fasteners	Inpro Part#
Wallguard Profile Hardware	#10 x 1-3/4" Phillips Pan Head sheet metal screw, 1/4" Plastic Alligator anchor	HWK-WG
Concrete Hardware for End Caps	#10 x 1-3/4" Phillips Pan Head sheet metal screw, 1/4" Plastic Alligator anchor	HWK-701C
Drywall Hardware for End Caps	#8 1-1/2" Phillips Indented Hex Washer Self-Drilling Screws #2PT ZP	HWK-701D
Concrete Hardware for Corners	#10 x 1-3/4" Phillips Pan Head sheet metal screw, 1/4" Plastic Alligator anchor	HWK-702/707C
Drywall Hardware for Corners	#8 1-1/2" Phillips Indented Hex Washer Self-Drilling Screws #2PT ZP	HWK-702/707DW

IPC® Door + Wall Protection

inpro.com • 800.222.5556 • 262.679.9010

World Headquarters S80 W18766 Apollo Drive, Muskego, WI 53150 USA

Installation Hotline: 866.394.6776

inpro®

Installation Instructions

700/700W/G2-700 WALL GUARD

Please read all instructions before installing wallguard.

Layout view

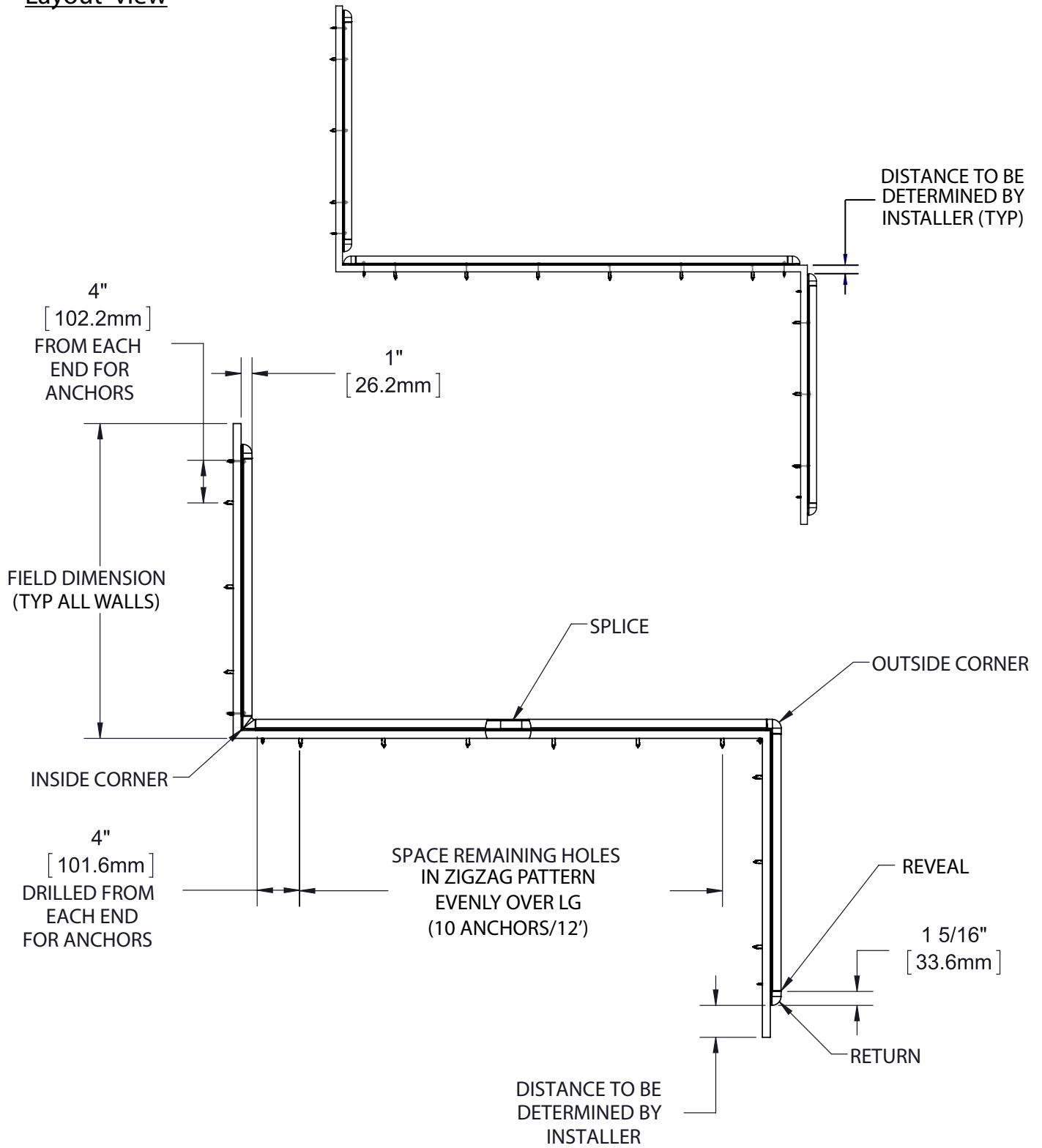

IPC® Door + Wall Protection

inpro.com • 800.222.5556 • 262.679.9010

World Headquarters S80 W18766 Apollo Drive, Muskego, WI 53150 USA

Installation Hotline: 866.394.6776

inpro®

Installation Instructions

700/700W/G2-700 WALL GUARD

Please read all instructions before installing wallguard.

Exploded view assembly

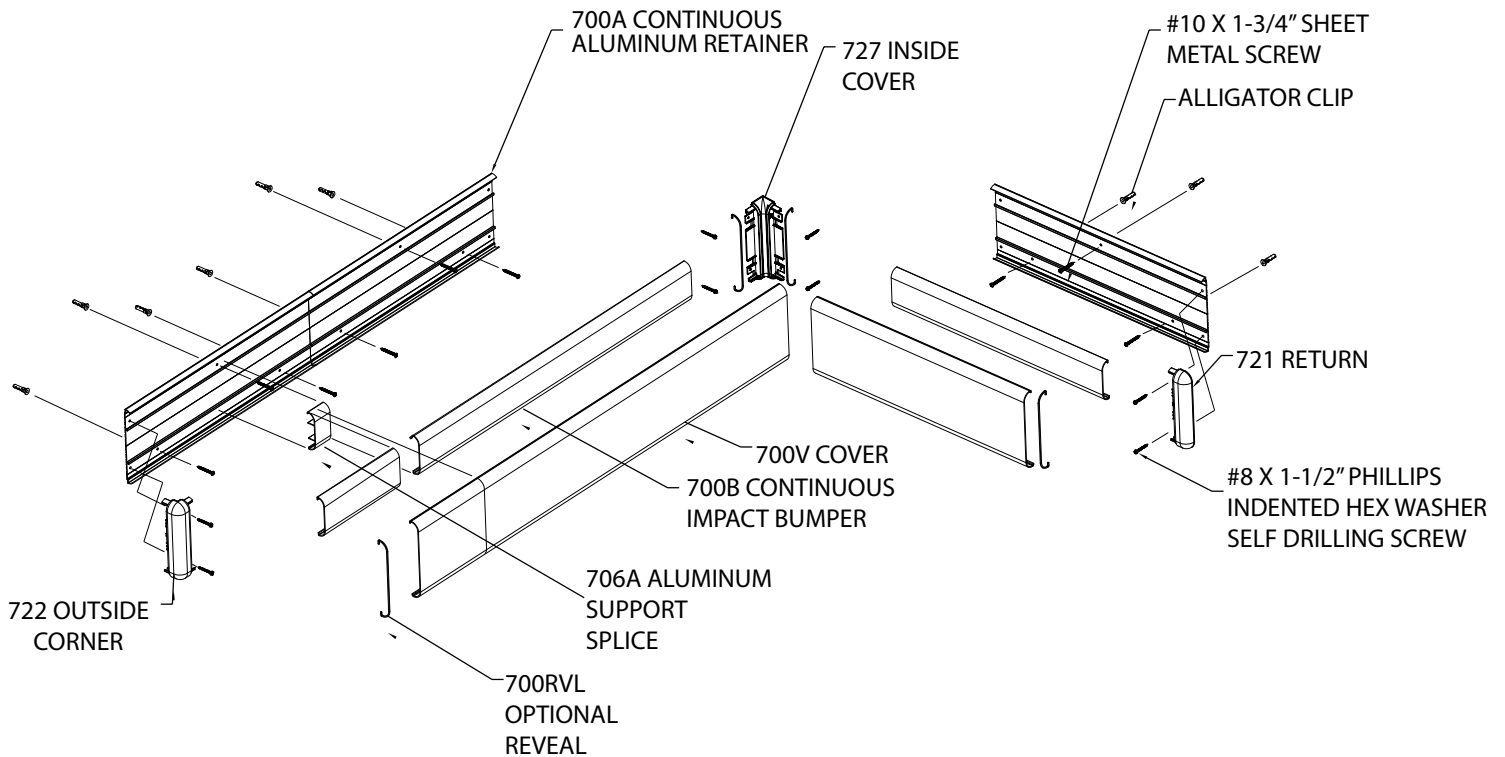

IPC® Door + Wall Protection

inpro.com • 800.222.5556 • 262.679.9010

World Headquarters S80 W18766 Apollo Drive, Muskego, WI 53150 USA

Installation Hotline: 866.394.6776

inpro®

Installation Instructions

700/700W/G2-700 WALL GUARD

Please read all instructions before installing wallguard.

FIG. 1

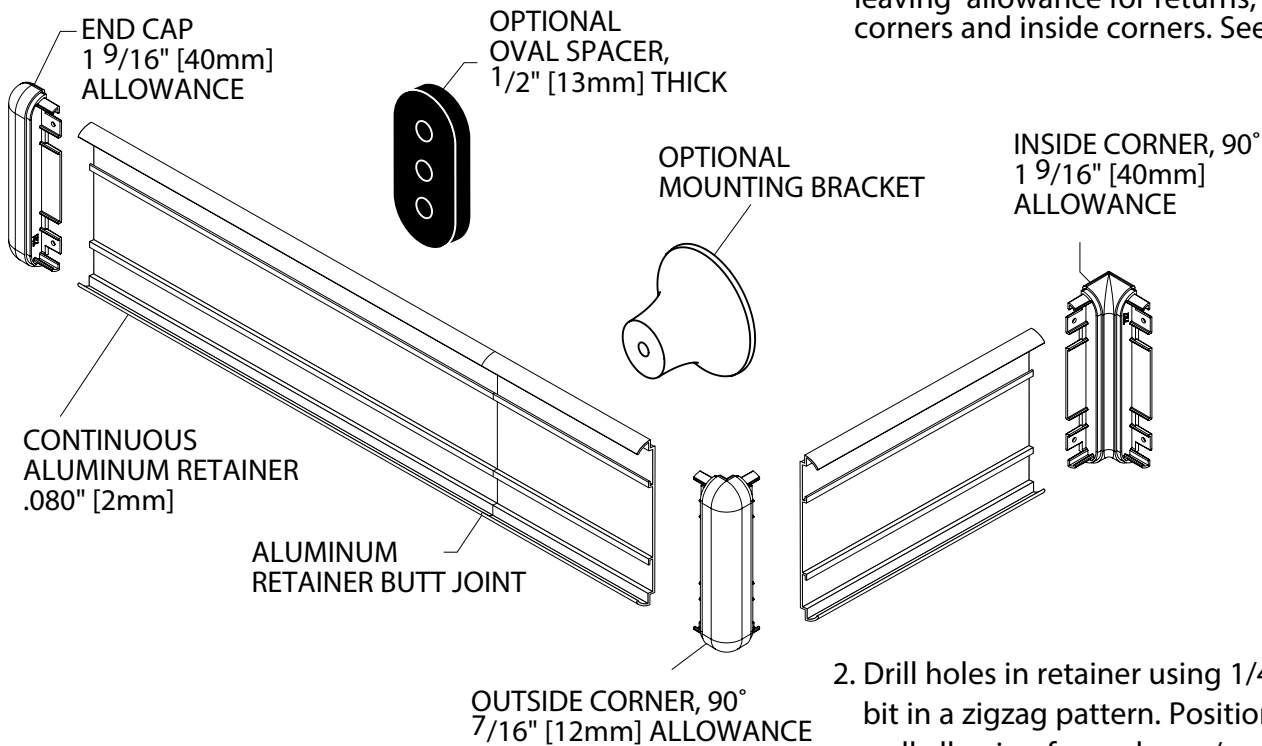

1. Cut aluminum retainer to desired length, leaving allowance for returns, outside corners and inside corners. See Figure 1.

FIG. 2

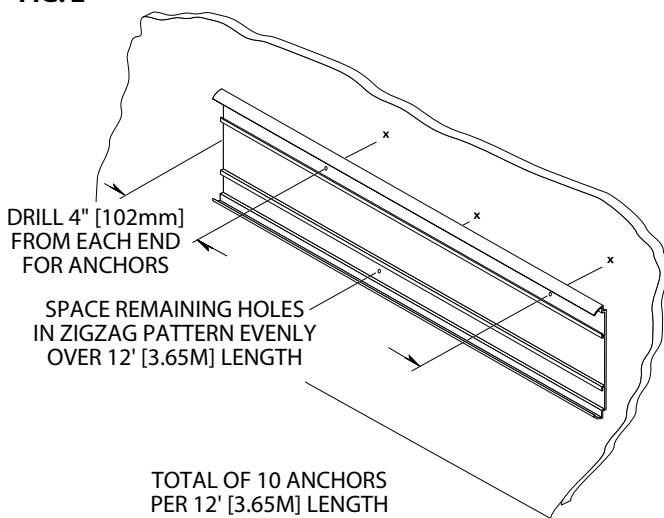

2. Drill holes in retainer using 1/4" [6mm] drill bit in a zigzag pattern. Position retainer on wall allowing for end caps/corners. Level and mark holes. See Fig. 2.

NOTE: For concrete or brick wall installation, drill 1/4" [6mm] holes, 3/8" [10mm] from each end of retainer for end caps/corners.

NOTE: If using brackets or rubber spaces, use bracket or spacer as a template to mark holes when drilling retainer. See Figures 2a & 2b.

FIG. 2a

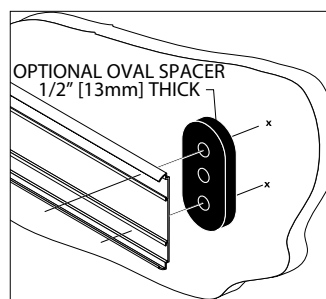
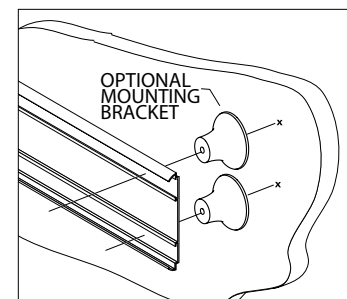

FIG. 2b



IPC® Door + Wall Protection

inpro.com • 800.222.5556 • 262.679.9010

World Headquarters S80 W18766 Apollo Drive, Muskego, WI 53150 USA

Installation Hotline: 866.394.6776

inpro®

Installation Instructions

700/700W/G2-700 WALL GUARD

Please read all instructions before installing wallguard.

FIG. 3

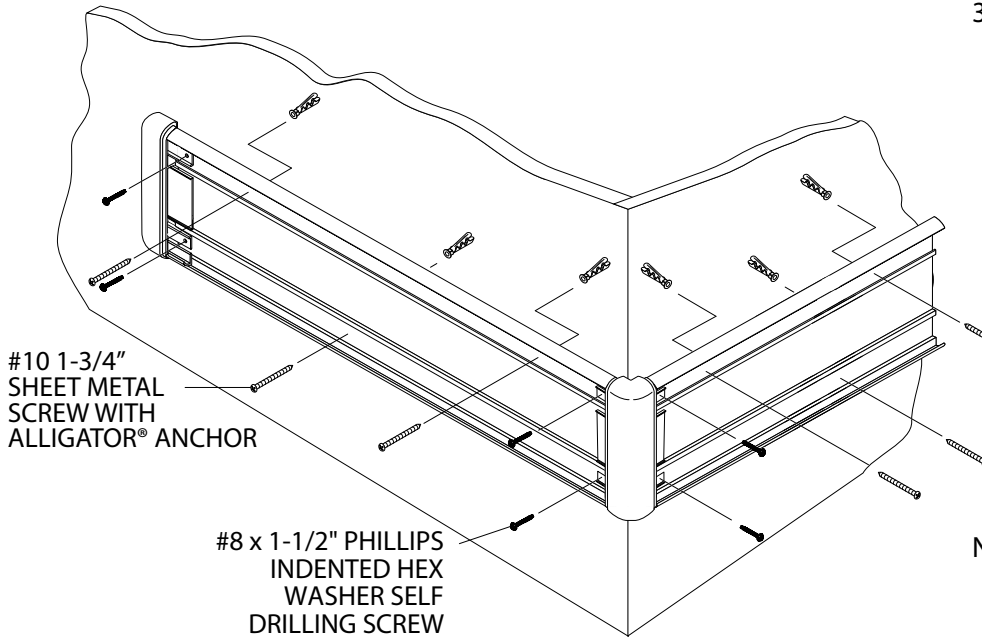

3. Drill marked holes on wall using a 1/4" [6mm] drill bit and position Alligator anchors into holes. Mount retainer on wall and tighten screws to secure. Slide end caps and corners onto the retainer and secure, leaving a 1/16" [1.5mm] gap between returns/corners and retainer to allow for adjustment. See Figure 3.

With lengths over 12' [3.65M], a splice support is recommended between butt joints for added support. See Figure 3a.

NOTE: For concrete or brick wall installation, use #10 x 1 3/4" Phillips pan head screws to secure end caps and corners.

FIG. 3a

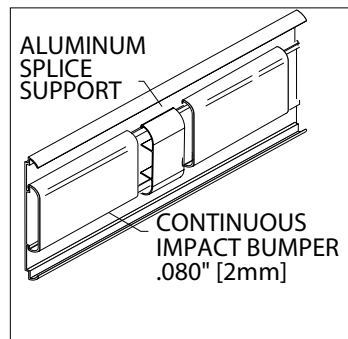

NOTE: If rubber spacers are used, attach them behind the retainer at all mounting hole locations, including those for end caps and corners.

NOTE: If brackets are used, use a 3/4" drill bit for toggle wings or a 1/2" drill bit for lead anchors to drill the marked holes on the wall. Attach end caps and corners with 5/8" hex bolt assembly inserted from the back.

FIG. 4

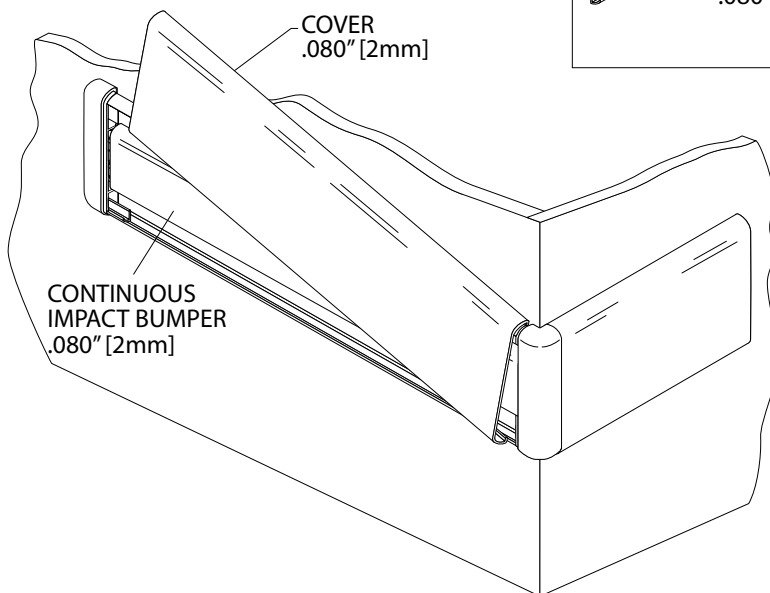

4. Cut the impact bumper to the length between the inside edge of the end caps/corners/splices. Position and snap bumper in place. Cut the cover to length between end caps and/or corners. (Note: trim factory edges square before installation). Position cover on retainer and adjust returns and/or corners for a tight fit. Push cover over the retainer until it snaps into place. See Figure 4.