

797-G01-100

JOINT WIDTH		MOVEMENT ±			
		HORIZONTAL		VERTICAL	
US	mm	US	mm	US	mm
4"	102	2"	51	1"	25

FINISH: HOT DIPPED GALV.

PROJECT:

CUSTOMER:

LOCATION:

APPLICATION- HEAVY DUTY
SEISMIC FLUSH MOUNT
FLOOR TO FLOOR SYSTEM

DATE: 4-20-17

SCALE: 1:2

DOC: CADJM.187/R4

inpro.

For More Information Visit: Inprocorp.com

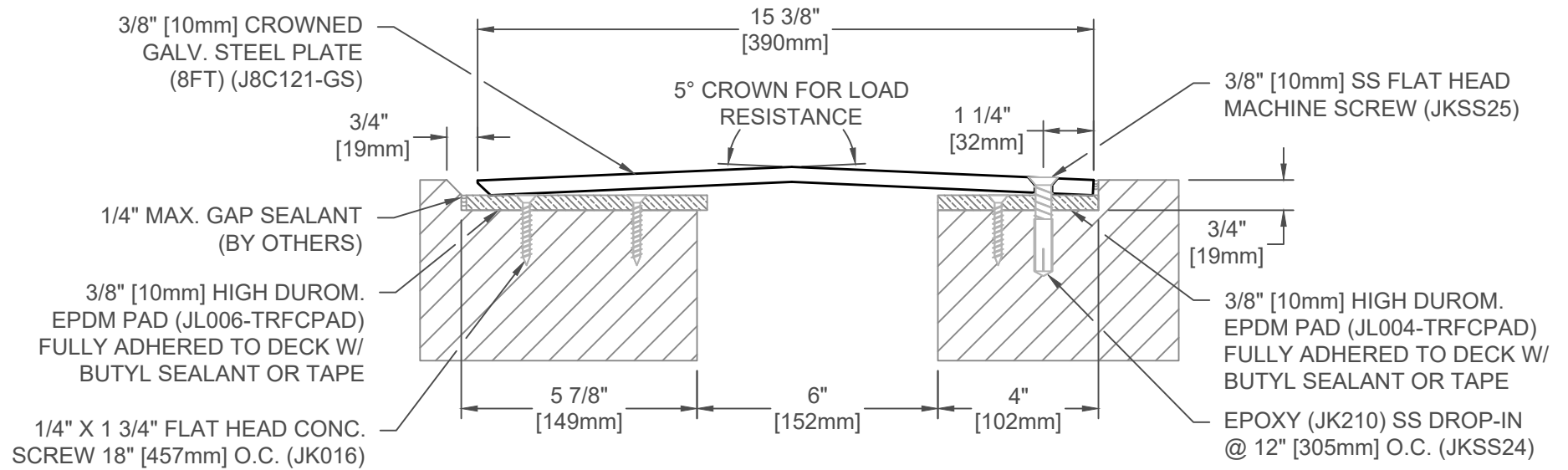

797-G01-150

JOINT WIDTH		MOVEMENT ±			
		HORIZONTAL		VERTICAL	
US	mm	US	mm	US	mm
6"	152	3"	76	1"	25

FINISH: HOT DIPPED GALV.

PROJECT:

CUSTOMER:

LOCATION:

APPLICATION - HEAVY DUTY
SEISMIC FLUSH MOUNT
FLOOR TO FLOOR SYSTEM

DATE: 4-20-17

SCALE: 1:4

DOC: CADJM.187/R4

inpro.

For More Information Visit: Inprocorp.com

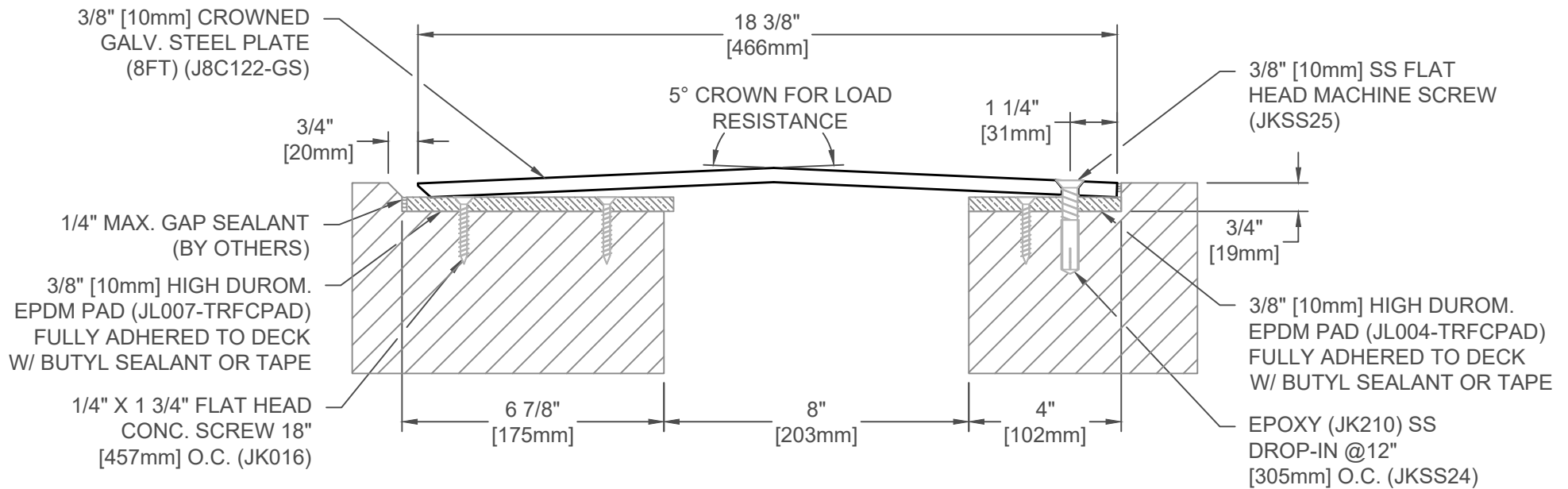

797-G01-200

JOINT WIDTH		MOVEMENT ±			
		HORIZONTAL		VERTICAL	
US	mm	US	mm	US	mm
8"	203	4"	102	1"	25

FINISH: HOT DIPPED GALV.

PROJECT:

CUSTOMER:

LOCATION:

APPLICATION - HEAVY DUTY
SEISMIC FLUSH MOUNT
FLOOR TO FLOOR SYSTEM

DATE: 4-20-17

SCALE: 1:4

DOC: CADJM.187/R4

inpro.

For More Information Visit: Inprocorp.com

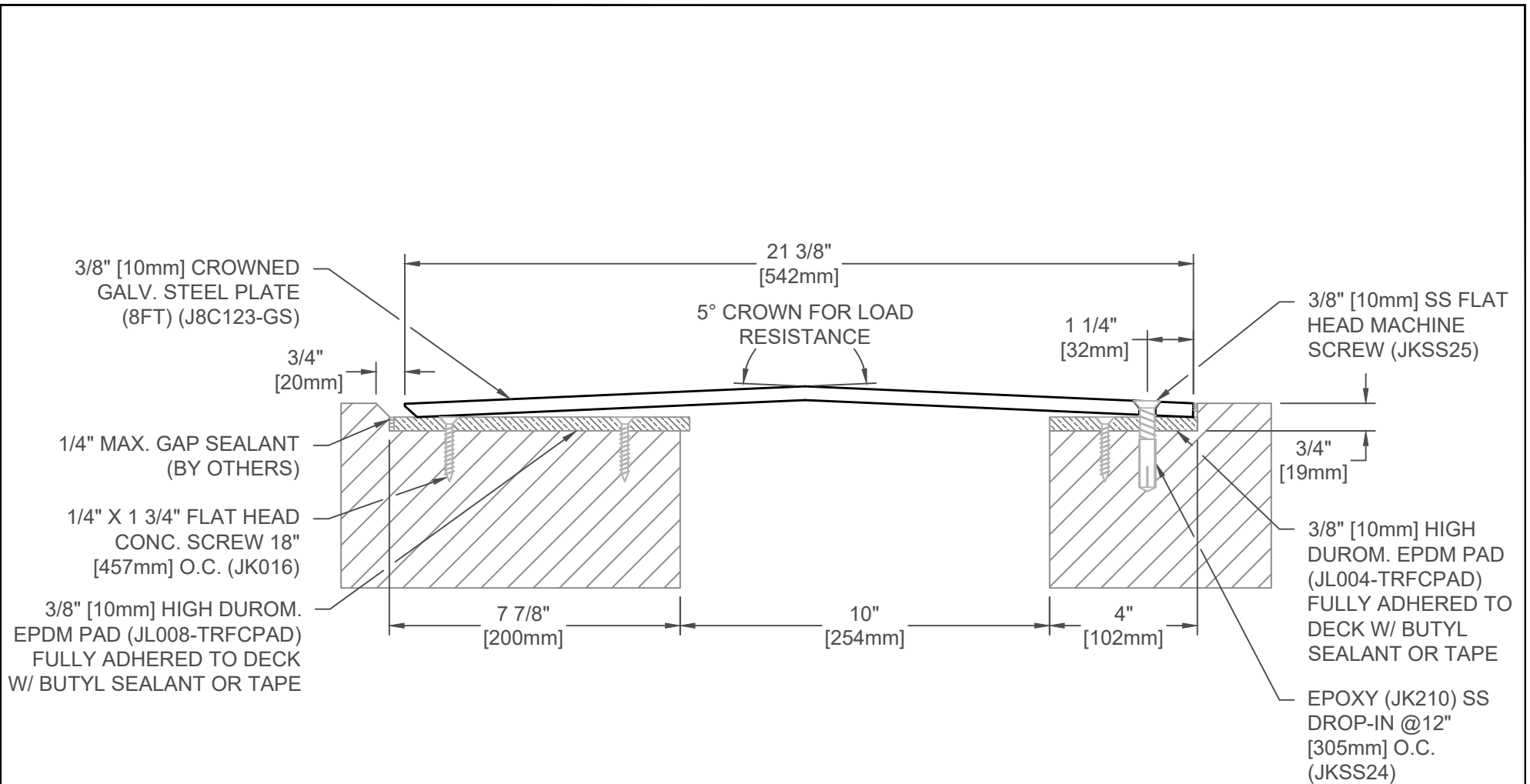

797-G01-250

JOINT WIDTH		MOVEMENT ±			
		HORIZONTAL		VERTICAL	
US	mm	US	mm	US	mm
10"	254	5"	126	1"	25

FINISH: HOT DIPPED GALV.
PROJECT:
CUSTOMER:
LOCATION:

APPLICATION - HEAVY DUTY
SEISMIC FLUSH MOUNT
FLOOR TO FLOOR SYSTEM

DATE:	4-20-17
SCALE:	1:4
DOC:	CADJM.187/R4



For More Information Visit: Inprocorp.com

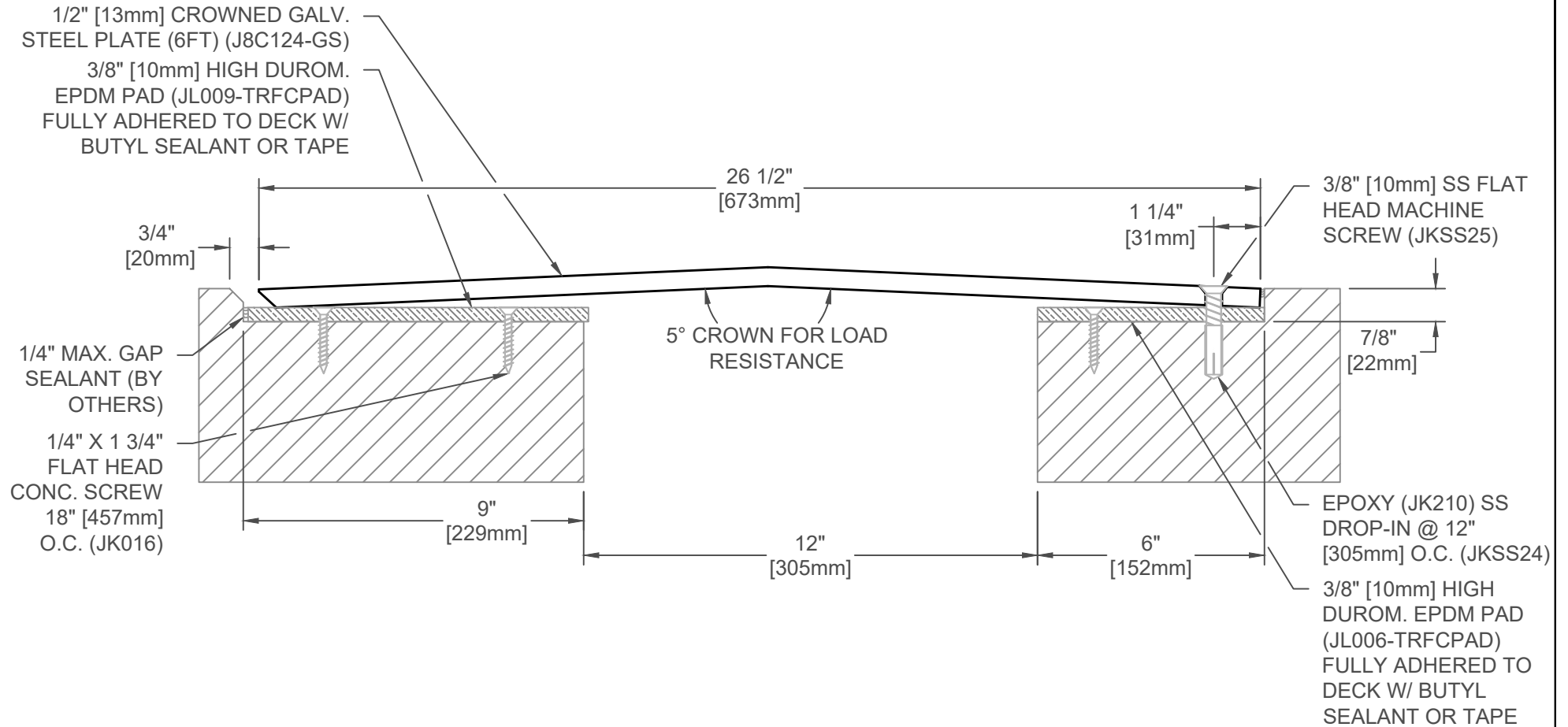

797-G01-300

JOINT WIDTH		MOVEMENT ±			
		HORIZONTAL		VERTICAL	
US	mm	US	mm	US	mm
12"	305	6"	152	1"	25

FINISH: HOT DIPPED GALV.
PROJECT:
CUSTOMER:
LOCATION:

APPLICATION - HEAVY DUTY
SEISMIC FLUSH MOUNT
FLOOR TO FLOOR SYSTEM

DATE:	4-20-17
SCALE:	1:4
DOC:	CADJM.187/R4



For More Information Visit: Inprocorp.com

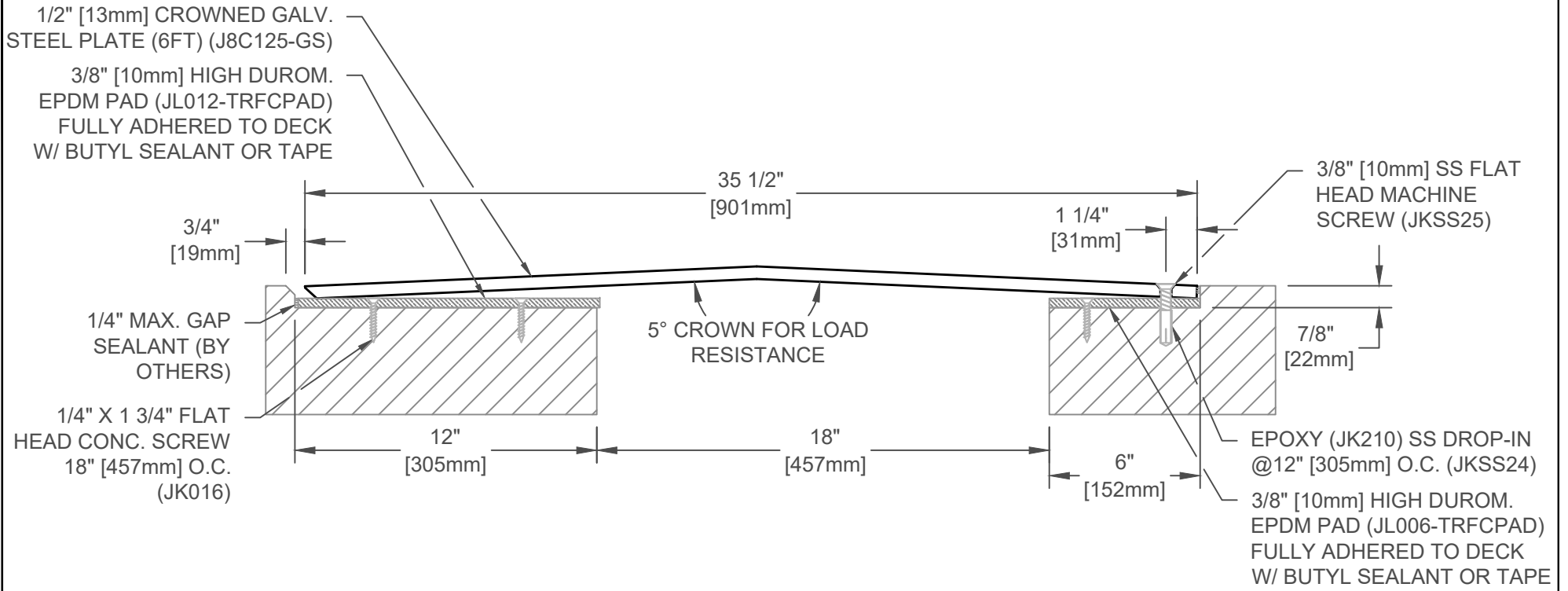

797-G01-450

JOINT WIDTH		MOVEMENT ±			
		HORIZONTAL		VERTICAL	
US	mm	US	mm	US	mm
18"	457	9"	229	1"	25

FINISH: HOT DIPPED GALV.
PROJECT:
CUSTOMER:
LOCATION:

APPLICATION - HEAVY DUTY
SEISMIC FLUSH MOUNT
FLOOR TO FLOOR SYSTEM

DATE:	4-20-17
SCALE:	1:6
DOC:	CADJM.187/R4



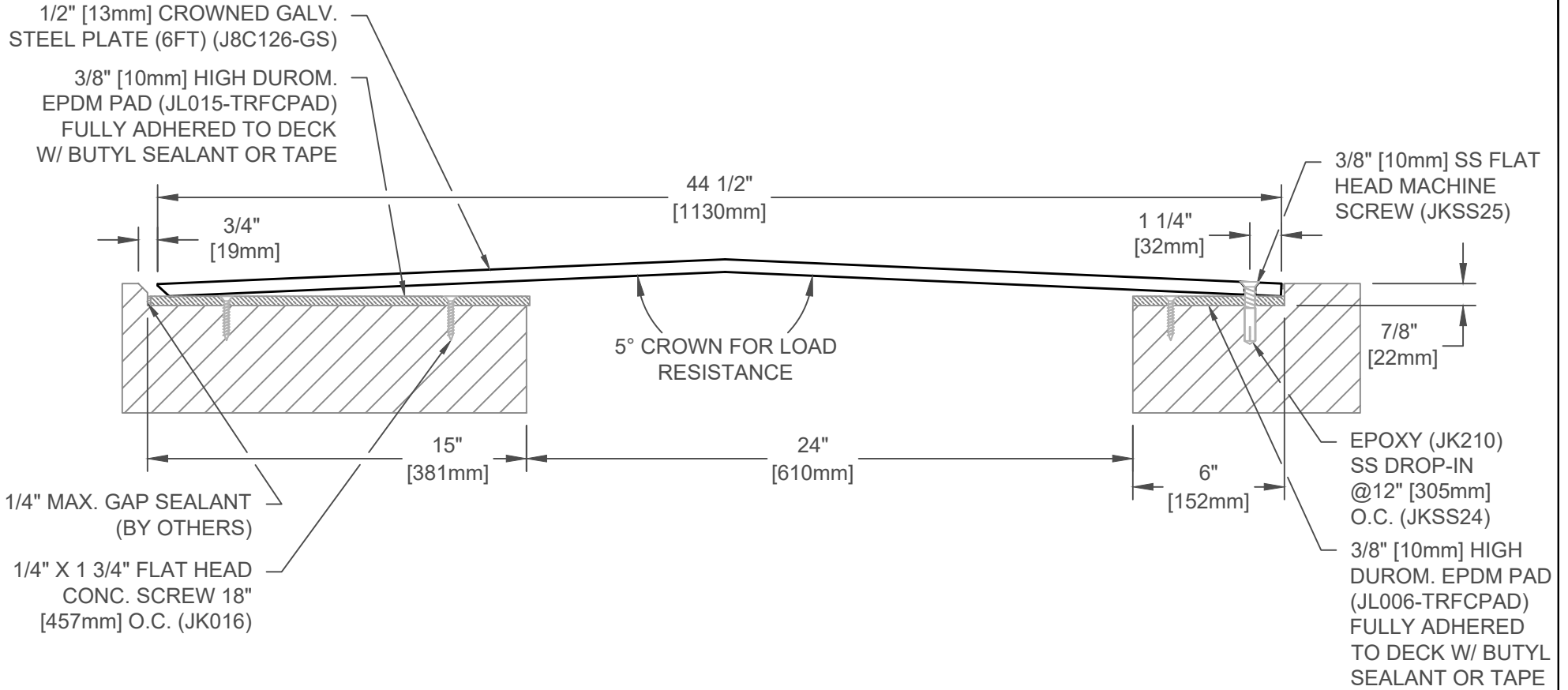

797-G01-600

JOINT WIDTH		MOVEMENT ±			
		HORIZONTAL		VERTICAL	
US	mm	US	mm	US	mm
24"	610	12"	305	1"	25

FINISH: HOT DIPPED GALV.
PROJECT:
CUSTOMER:
LOCATION:

APPLICATION - HEAVY DUTY
SEISMIC FLUSH MOUNT
FLOOR TO FLOOR SYSTEM

DATE:	4-20-17
SCALE:	1:6
DOC:	CADJM.187/R4

inpro.
For More Information Visit: Inprocorp.com