

900M Handrail

Suggested Specifications



900M WITH 909SS STAINLESS
STEEL BRACKET



900M WITH 909SS STAINLESS
STEEL MRND BRACKET

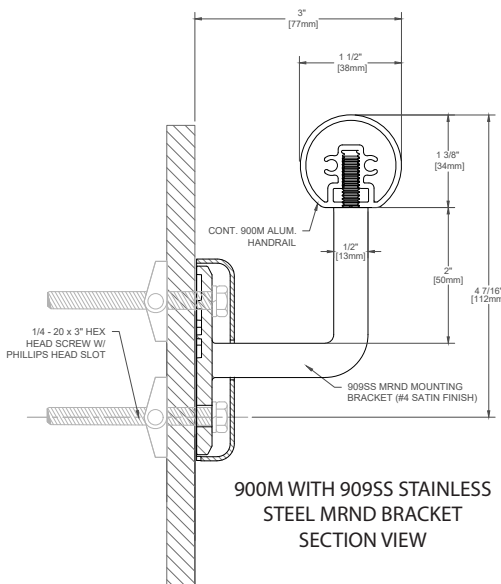
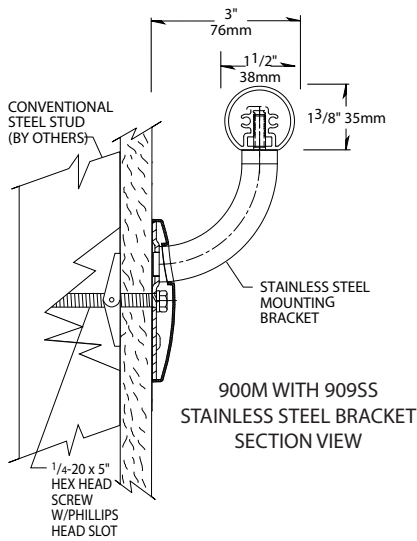

- 1-3/8" (35mm) height x 1-1/2" (38mm) gripping diameter, extends 3" (76mm) from wall
- Available in Metal Tone finishes
- Easy installation, clean-up and maintenance
- Meets ADA and ANSI criteria
- Manufactured in 12' (3.66m) standard lengths
- All mounting fasteners are included with each order
- May qualify for LEED MR Credit 4.1 = 1 credit; MR Credit 4.2 = 1 credit

IPC.671/REV.4

900M Handrail

Suggested Specifications

PART 1 - GENERAL

1.01 SUMMARY

A. Handrail systems for pedestrian safety and wall protection

1.02 SECTIONS INCLUDES

A. 900M Aluminum Handrail System

1.03 REFERENCES

- A. American National Standards Institute (ANSI)
- B. American Society for Testing and Materials (ASTM)
- C. American with Disabilities Act (ADA)
- D. National Fire Protection Association (NFPA)

1.04 SYSTEM DESCRIPTION

- A. Performance Requirements: Provide metal handrail systems that conform to the following requirements of regulatory agencies and the quality control of IPC Door and Wall Protection Systems, Inpro Corporation.
- 1. Fire Performance Characteristics: Provide metal handrail components conforming with NFPA Class A fire rating. Surface burning characteristics, as determined by ASTM E-84, shall be flame spread of 0 and smoke development of 5.
 - 2. Fungal and Bacterial Resistance: Provide powder coated metal components that does not support fungal or bacterial growth as tested in accordance with ASTM G-21 and ASTM G-22.
 - 3. Chemical and Stain Resistance: Provide powder coat materials that show resistance to stain when tested in accordance with applicable provisions of ASTM D-543.
 - 4. Code Compliance: Provide handrails that comply with all current ANSI and ADA requirements.

1.05 SUBMITTALS

- A. Product Data: Manufacturer's printed product data for each product indicated in this section.
- B. Detail Drawings: Mounting details with appropriate fasteners for specific project substrates.
- C. Samples: Verification samples of handrail, 10" (254mm) long, in full size profiles with mounting brackets of each type indicated.
- D. Manufacturer's Installation Instructions: Printed installation instructions for each handrail.

1.06 DELIVERY, STORAGE AND HANDLING

- A. Deliver materials in unopened factory packaging to the jobsite.
- B. Inspect materials at delivery to assure that specified products have been received.
- C. Store in original packaging in a climate controlled environment away from direct sunlight.

1.07 WARRANTY

- A. Standard IPC limited lifetime warranty against material and manufacturing defects.

PART 2 PRODUCTS

2.01 MANUFACTURERS

- A. Acceptable Manufacturer: IPC Door and Wall Protection Systems, Inpro Corporation, PO Box 406, Muskego, WI 53150 USA;

Telephone 800-543-1729, Fax: 888-715-8407,

Internet address: www.inprocorp.com

B. Substitutions: Not permitted

C. Provide all handrails and wall protection from a single manufacturer.

2.02 LEED Criteria

A. Provide Handrail systems with metal components that have recycled content.

- 1. MR CR4.1, 10% (post-consumer + 1/2 pre-consumer), 1 Credit
- 2. MR CR4.2, 20% (post-consumer + 1/2 pre-consumer), 1 Credit

2.03 MANUFACTURED UNITS

A. 900M Metal Handrail System

- 1. 900M Handrail 1-1/2" (38mm) gripping diameter, system extends 3" (76mm) from the wall. System includes 1-1/2" (38mm) diameter metal top rail with stainless steel brackets

2.04 MATERIALS

A. Aluminum:

- 1. Continuous aluminum rail of .080" (2mm) thickness shall be fabricated from 6063-T5 aluminum.

B. Stainless Steel:

- 1. Stainless Steel: Stainless Steel Brackets shall be made of type 201SS with type 304 stainless steel flange cover.

2.05 COMPONENTS

- A. Handrail returns, outside corners and inside corners shall be stainless steel and a finish/color to match handrails.
- B. Stainless steel brackets shall be fabricated from cast stainless steel with a brushed finish or a powder coat finish.
- C. Fasteners: All mounting systems accessories appropriate for substrates indicated on the drawings shall be provided.

2.06 FINISHES

- A. Handrail Color: Color or pattern of the handrail to be selected by the architect from the Inpro Corporation metal tone color palette.
- B. Stainless Steel Brackets
 - 1. Color of the stainless steel bracket to be selected by the architect from the solid color metal tone color palette.
 - 2. Color of stainless steel shall be #4 satin finish stainless.

PART 3 EXECUTION

3.01 INSTALLERS

- A. Installer should be familiar with the installation of fine finished wood products.

3.02 EXAMINATION

- A. Examine areas and conditions in which handrail will be installed.
 - 1. Complete all finishing operations, including painting, before beginning installation of handrail system materials.
 - 2. Wall surface shall be dry and free from dirt, grease and

loose paint.

3.03 PREPARATION

- A. General: Prior to installation, clean substrate to remove dust, debris and loose particles.

3.04 INSTALLATION

- A. General: Locate the handrail as indicated on the approved detail drawing for the appropriate substrate and in compliance with the IPC installation instructions. Install handrail level and plumb at the height indicated on the drawings.

3.05 CLEANING

- A. At completion of the installation, clean surfaces in accordance with the IPC clean-up and maintenance instructions.