

# Installation Instructions

## 900M/900MF Handrail

**FIG. 1**

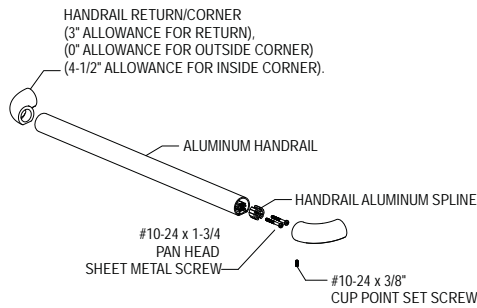

1. Cut the aluminum handrail to the desired lengths leaving allowances for returns, outside corners and inside corners. Break sharp edges with fine Emory cloth. See Figure 1.

Handrail Allowances:  
 Return – 3" [75mm]  
 Inside corner – 4-1/2" [114mm]  
 Outside corner – 0"

2. Bracket Spacing: Use brackets 4" [102mm] from each end and spaced a maximum of 32". Drill 1/4" [6mm] holes on the bottom of the handrail aluminum for brackets. Be careful to drill only through the outer wall of the handrail aluminum. See Figure 2.

**FIG. 2**

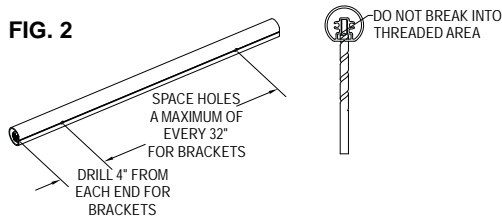

3. To attach returns and corners:

- Attach splines to handrail using two #10 x 1-3/4" sheet metal screws per spline. See Figure 3a.
- Attach returns and corners to handrail by sliding component over the spline and secure with set screws. See Figure 3b.

**FIG. 3a**

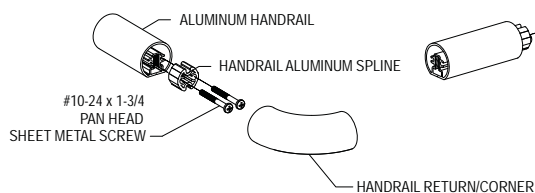

**FIG. 3b**

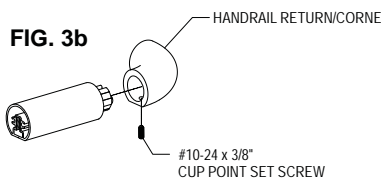

IPC.642/REV.2

# Installation Instructions

## 900M/900MF Handrails

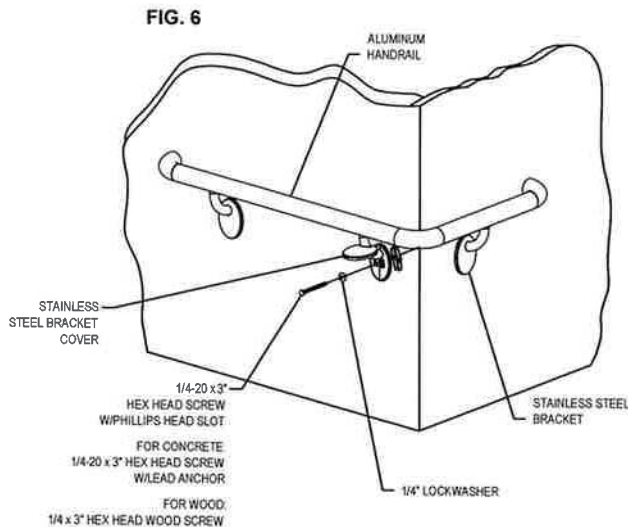
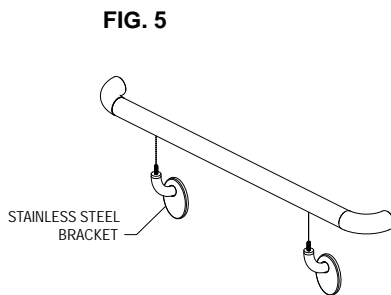
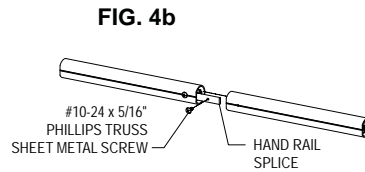
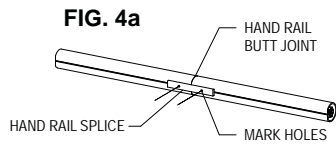

4. For lengths longer than 12' [3.6m], use a splice to join sections. Butt the two sections together, using a splice as a template, mark the hole locations. See Figure 4a. Drill 1/4" [6mm] holes on the bottom of the handrail aluminum for the splice. Connect the two pieces using the splice and two #10-24 x 5/16" [8mm] Phillips truss head screws. (Note: splice must be positioned inside handrail). See Figure 4b.

5. Slip stainless steel cover over the bracket post. Screw brackets into the holes on the bottom of the rail and align mounting flanges. See Figure 5.

6. Snap a chalk line on the wall 4-7/16" [113mm] below the top of the handrail. Drill 3/4" [19mm] holes for toggle bolts (drywall/metal stud installation), 1/2" [13mm] holes for lead anchor (concrete wall installation) or 1/8" [3mm] pilot hole (wood screw into wood studs). Attach the stainless steel bracket and handrail assembly to the wall. Level and tighten bracket to the wall. Snap stainless steel bracket cover on the bracket flange. See Figure 6.

Installation Hotline • 866.EZINPRO

Inprocorp.com • 800.222.5556 • 262.679.9010

World Headquarters S80 W18766 Apollo Drive, Muskego, WI 53150 USA

IPC®

DOOR + WALL PROTECTION SYSTEMS  
A DIVISION OF INPRO®