

NOTE:
 SURROUNDING SUBSTRATE MUST MATCH OR EXCEED PERFORMANCE CAPABILITIES OF THE 990 FIRE RATED FOAM TO ACHIEVE FIRE RATING

990 FOAM LENGTH - 6' 6" [1981mm]
 PLATE LENGTH - 10' [3048mm]

SYSTEM	JOINT WIDTH		SEAL HEIGHT		MOVEMENT ±			
	US	mm	US	mm	COMPRESSION		EXPANSION	
	US	mm	US	mm	US	mm	US	mm
990H3-050 UC	1/2"	13	4"	102	1/8"	3	1/8"	3
990H3-100 UC	1"	25	4"	102	1/4"	6	1/4"	6
990H3-150 UC	1 1/2"	38	4"	102	3/8"	10	3/8"	10
990H3-200 UC	2"	51	4"	102	1/2"	13	1/2"	13
990H3-250 UC	2 1/2"	64	4"	102	5/8"	16	5/8"	16
990H3-300 UC	3"	76	4"	102	3/4"	19	3/4"	19
990H3-350 UC	3 1/2"	89	4"	102	7/8"	22	7/8"	22

FINISH: N/A

PROJECT:

CUSTOMER:

LOCATION:

APPLICATION-
 FLOOR/FLOOR AND FLOOR/WALL
 3 HOUR FIRE RATED

DATE: 2-25-16

SCALE: 1:2

DOC: CADJM.176/R3

inpro[®]

For More Information Visit: Inprocorp.com

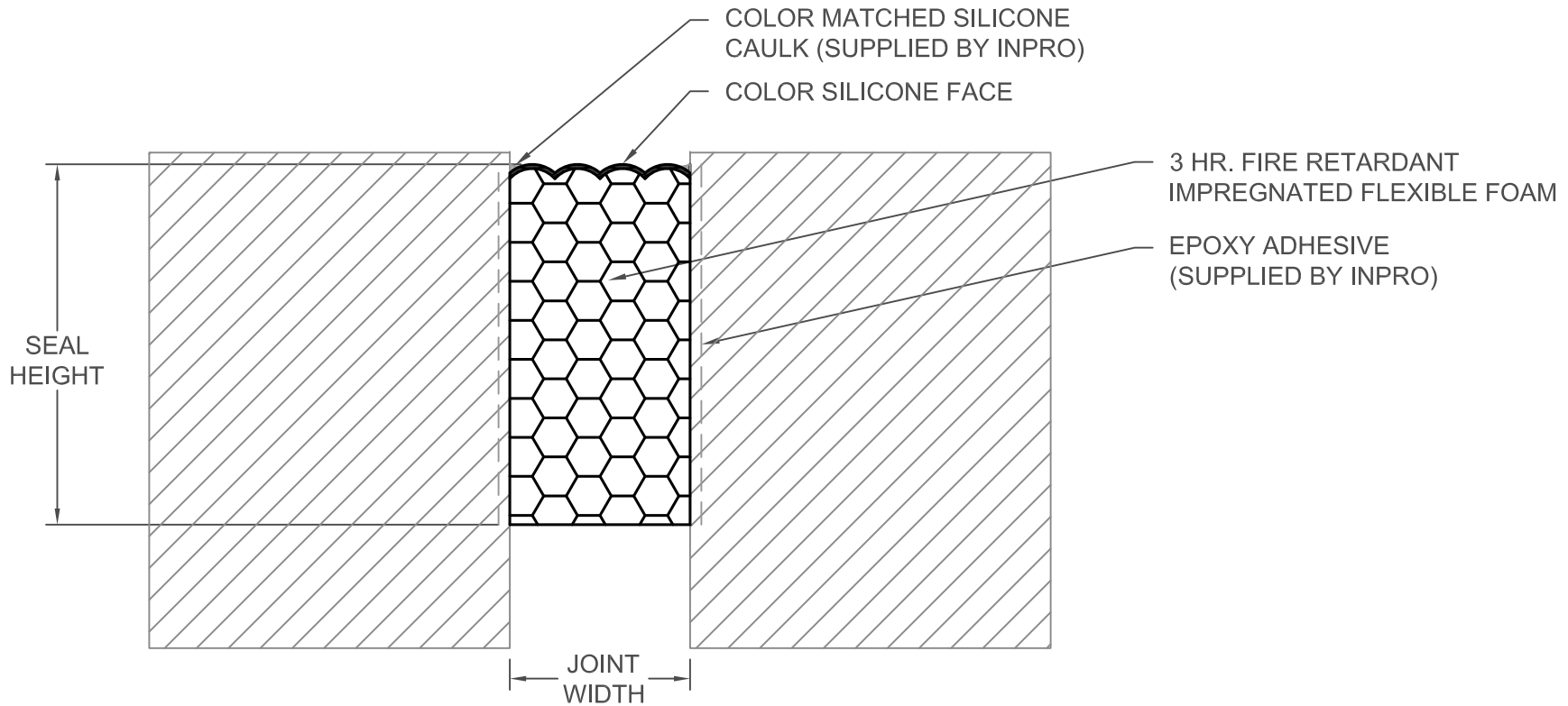

NOTE:
 SURROUNDING SUBSTRATE MUST MATCH OR EXCEED PERFORMANCE CAPABILITIES OF THE 990 FIRE RATED FOAM TO ACHIEVE FIRE RATING

990 FOAM LENGTH - 6' 6" [1981mm]
 PLATE LENGTH - 10' [3048mm]

SYSTEM	JOINT WIDTH		SEAL HEIGHT		MOVEMENT ±			
	US	mm	US	mm	COMPRESSION		EXPANSION	
	US	mm	US	mm	US	mm	US	mm
990H3-050	1/2"	13	4"	102	1/8"	3	1/8"	3
990H3-100	1"	25	4"	102	1/4"	6	1/4"	6
990H3-150	1 1/2"	38	4"	102	3/8"	10	3/8"	10
990H3-200	2"	51	4"	102	1/2"	13	1/2"	13
990H3-250	2 1/2"	64	4"	102	5/8"	16	5/8"	16
990H3-300	3"	76	4"	102	3/4"	19	3/4"	19
990H3-350	3 1/2"	89	4"	102	7/8"	22	7/8"	22

FINISH: N/A
PROJECT:
CUSTOMER:
LOCATION:

APPLICATION-
 FLOOR/FLOOR AND FLOOR/WALL
 3 HOUR FIRE RATED

DATE:	2-25-16
SCALE:	1:2
DOC:	CADJM.176/R3



For More Information Visit: Inprocorp.com

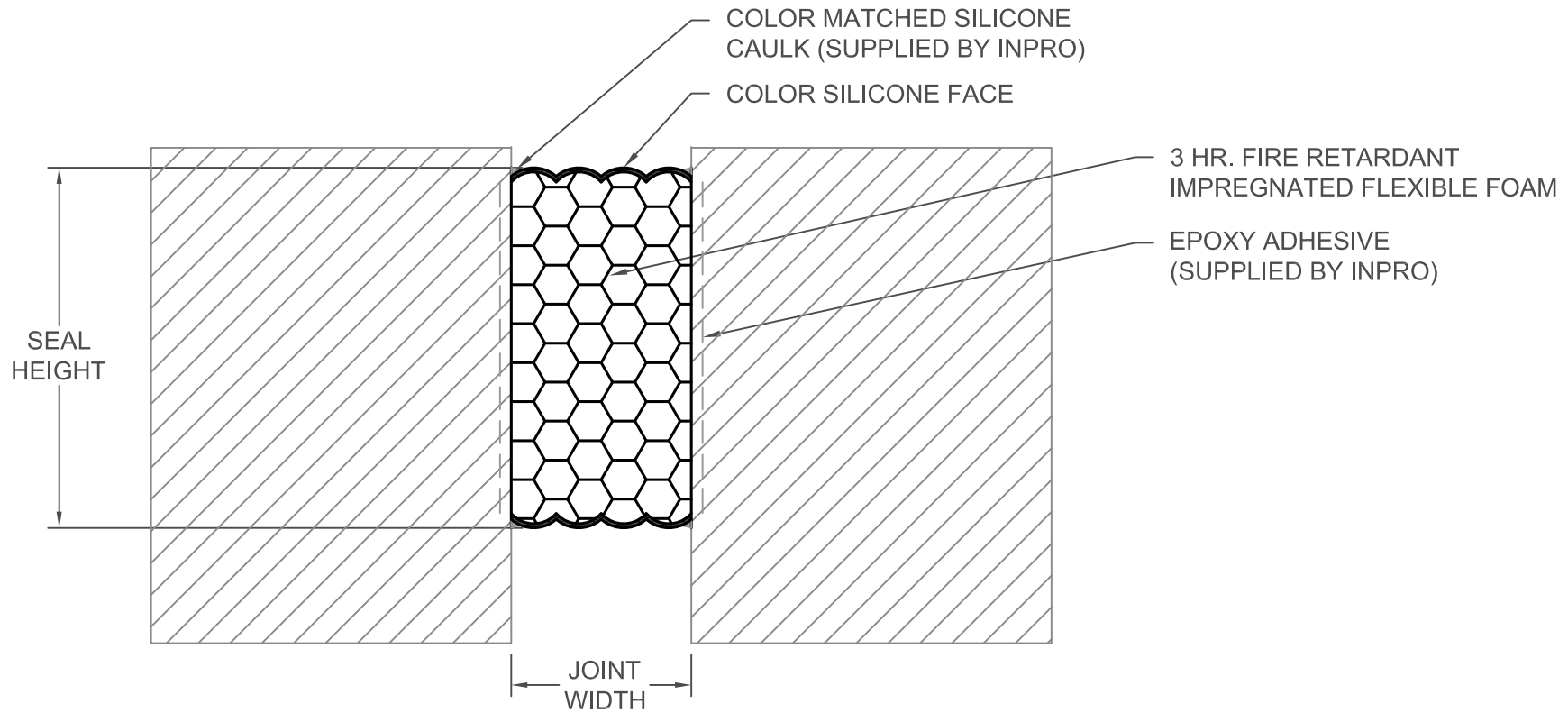

NOTE:
 SURROUNDING SUBSTRATE MUST
 MATCH OR EXCEED PERFORMANCE
 CAPABILITIES OF THE 990 FIRE
 RATED FOAM TO ACHIEVE FIRE
 RATING

990 FOAM LENGTH - 6' 6" [1981mm]
 PLATE LENGTH - 10' [3048mm]

SYSTEM	JOINT WIDTH		SEAL HEIGHT		MOVEMENT ±			
	US	mm	US	mm	COMPRESSION		EXPANSION	
	US	mm	US	mm	US	mm	US	mm
990H3-050 DS	1/2"	13	4"	102	1/8"	3	1/8"	3
990H3-100 DS	1"	25	4"	102	1/4"	6	1/4"	6
990H3-150 DS	1 1/2"	38	4"	102	3/8"	10	3/8"	10
990H3-200 DS	2"	51	4"	102	1/2"	13	1/2"	13
990H3-250 DS	2 1/2"	64	4"	102	5/8"	16	5/8"	16
990H3-300 DS	3"	76	4"	102	3/4"	19	3/4"	19
990H3-350 DS	3 1/2"	89	4"	102	7/8"	22	7/8"	22
990H3-400 DS	4"	102	4"	102	1"	25	1"	25

FINISH: N/A
PROJECT:
CUSTOMER:
LOCATION:

APPLICATION-
 FLOOR/FLOOR AND FLOOR/WALL
 3 HOUR FIRE RATED

DATE:	2-25-16
SCALE:	1:2
DOC:	CADJM.176/R3

inpro.

For More Information Visit: Inprocorp.com