

Continuum™ Rigid Sheet

Suggested Specifications

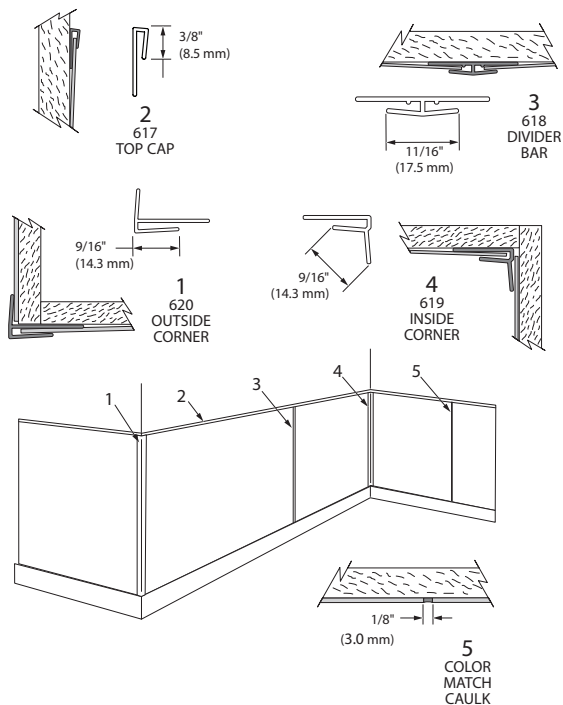

- W™ Rigid Sheet stands up to hot cold and high moisture environments.
- Fiberglass Free
- Impact Resistant
- Moisture Resistant
- Bacterial and Fungal Resistant
- Easy to Cut on Site
- Integrates seamlessly with Stainless Steel Cove Base to create a hygienic, water tight transition from floor to wall.
- Available in standard 4' (1.22m) x 8' (2.44m) & 4' (1.22m) x 10' (3.04m) (WxL) sheets.
- Thickness of .080 (2mm) available
- Top Cap, Divider Bar, Inside Corner and Outside Corner trim pieces available
- Has been tested and meets GREENGUARD Environmental Institute's and the state of California's requirements for low emitting products as tested by Air Quality Sciences
- Has been tested and meets the GREENGUARD Children & School chemical emissions levels

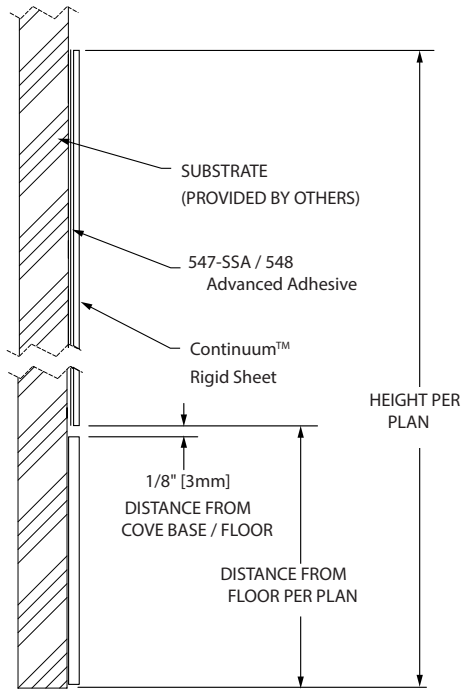

IPC.3219/REV.6

Continuum™ Rigid Sheet

Suggested Specifications

PART 1 - GENERAL

1.01 SUMMARY

A. Continuum™ Rigid Sheet for wall protection and decoration

1.02 SECTION INCLUDES

A. Continuum™ Rigid Sheet

1.03 REFERENCES

A. American Society for Testing and Materials (ASTM)

B. International Standards Organization for Standardization (ISO)

C. National Fire Protection Association (NFPA)

D. National Sanitation Foundation (NSF)

E. Society of Automotive Engineers (SAE)

F. International Standards Organization for Standardization (ISO)

1.04 SYSTEM DESCRIPTION

A. Performance Requirements: Provide Continuum™ Rigid Sheet systems that conform to the following requirements of regulatory agencies and the quality control of IPC Door and Wall Protection Systems™, InPro Corporation.

1. Fire Performance Characteristics: Provide Continuum™ Rigid Sheet conforming with NFPA Class A fire rating. Surface burning characteristics as determined by ASTM E84 shall be flame spread of 25 or less and smoke development of 450 or less.

2. Chemical and Stain Resistance: Provide material that shows resistance to stain when tested in accordance with ASTM D543. Continuum™ Rigid Sheet shall show "No Change" from reagents.

3. Effect of Household Chemicals: Provide material that is effective against reaction to household chemicals when tested in accordance with ASTM D1308. Continuum™ Rigid Sheet shall show "No Change" from reagents.

4. Mold Growth Resistance: Provide material that is resistant to mold growth when tested in accordance with ASTM D3273. Continuum™ Rigid Sheet shall show no growth.

5. Abrasion Resistance: Provide material that is resistant to abrasion when tested in accordance with ASTM D4060. Continuum™ Rigid Sheet shall have a 0.01 % weight loss; CS-17 wheels 1,000 gram weight at 25 cycles.

6. Impact Resistance: Provide material that is resistant to impact when tested in accordance to ASTM D4226. Continuum™ Rigid Sheet shall show a mean failure energy of 11.5 in-lbs.

7. Fungi Resistance: Provide material that is resistant to fungi when tested in accordance to ASTM G21 and ISO 846 method A. Continuum™ Rigid Sheet shall show no fungal growth.

8. Bacterial Resistance: Provide material that is resistant to bacteria when tested in accordance to ASTM G22 and ISO 846 method C. Continuum™ Rigid Sheet shall show no bacterial growth.

9. Effect of Liquids: Provide material that is effective against reaction to liquids when tested in accordance with ISO 2812. Continuum™ Rigid Sheet shall have a "0" rating (no effect) from reagents.

10. Cleanroom Particle Concentration: Provide Continuum™ Rigid Sheet that achieved an ISO class number of "Class 6" when evaluated using the test procedure outlined in VDI 2083-17 2013 section 6.2 (Particle Emission) and classified using ISO 14644.1-

2015. Provide Continuum™ Rigid Sheet that achieved a classification of "Class 5" when utilizing Federal Standard 209E for the determination for classification.

11. Indoor Air Quality: Provide material that passes the test requirements of ISO 16000-9. Continuum™ Rigid Sheet shall have a TVOC concentration of <5 µg/m³ and Styrene concentration was <1 µg/m³.

12. GREENGUARD Certified: Provide Continuum™ Rigid Sheet that has a GREENGUARD Gold Certification.

13. Color Consistency: Provide components matched in accordance with SAE J-1545 - (Delta E) with a color difference no greater than 1.0 units using CIE Lab, CIE CMC, CIE LCh, Hunter Lab or similar color space scale systems.

14. NSF Certified: Provide Continuum™ Rigid Sheet that is NSF certified.

1.05 SUBMITTALS

A. Product Data: Manufacturer's printed product data for each type of Continuum™ Rigid Sheet specified.

B. Detail Drawings: Mounting details with the appropriate adhesives for specific project substrates.

C. Samples: Verification samples of Continuum™ Rigid Sheet, 5" x 8" (127mm x 203mm) piece, of each type and color indicated.

D. Manufacturer's Installation Instruction: Printed installation instructions for Continuum™ Rigid Sheet.

1.06 DELIVERY, STORAGE AND HANDLING

A. Deliver materials in unopened factory packaging to the jobsite

B. Inspect materials at delivery to assure that specified products have been received.

C. Store in original packaging in a climate controlled location away from direct sunlight.

1.07 PROJECT CONDITIONS

A. Environmental Requirements: Products must be installed in an interior climate controlled environment.

1.08 WARRANTY

A. Standard IPC Limited Lifetime Warranty against material and manufacturing defects.

PART 2 - PRODUCTS

2.01 MANUFACTURER

A. Acceptable Manufacturer:
IPC Door and Wall Protection Systems, InPro Corporation, PO Box 406 Muskego, WI 53150 USA; Telephone: 800.222.5556, Fax: 888.715.8407, www.inprocorp.com

B. Substitutions: Not permitted

C. Provide all Continuum Rigid Sheet and wall protection from a single source.

2.02 MANUFACTURED UNITS

A. Continuum™ Rigid Sheet

1. Continuum™ Rigid Sheet Options

Item # Dimensions Thickness
610-XXXX: 4'x8' (1.22m x 2.44m) .080" = 5/64" (2mm) standard

61010-XXXX: 4'x10' (1.22m x 3.04m) .080" = 5/64" (2mm) available

B. Accessories:

1. Trim

61710 Top Cap; Length: 10' (3.04m)

61810 Vertical Divider Bar; Length: 10' (3.04m)

61910 Inside Corner; Length: 10' (3.04m)

62010 Outside Corner; Length: 10' (3.04m)

2. Color Matched Caulk

3. Two-Part Urethane Waterproof Sealant (Bright White)

2.03 MATERIALS

A. Vinyl: Continuum™ Rigid Sheet shall be made from chemical and stain-resistant unplasticized polyvinyl chloride (uPVC) with the addition of impact modifiers. No plasticizers shall be added (plasticizers may aid in bacterial growth).

2.04 ACCESSORIES

A. Top caps, inside corners, divider bars and outside corners shall be made of extruded PVC.

2.05 FINISHES

A. Continuum™ Rigid Sheet colors to be selected by the architect. Surface shall have a velvet texture.

B. Vinyl Accessories: Top caps, inside corners, divider bars and outside corners shall be of a color matching the IPC.

PART 3 - EXECUTION

3.01 EXAMINATION

A. Examine areas and conditions in which the Continuum™ Rigid Sheet will be installed.

1. Complete all finishing operations, including painting, before beginning installation of Continuum™ Rigid Sheet materials.

B. Wall surface shall be dry and free from dirt, grease and loose paint.

3.02 PREPARATION

A. General: Prior to installation, clean substrate to remove dust, debris and loose particles.

3.03 INSTALLATION

A. General: Locate the Continuum™ Rigid Sheet as indicated on the approved detail drawing for the appropriate substrate and in compliance with the IPC installation instructions. Install level and plumb at the height indicated on the drawings.

B. Installation of Continuum™ Rigid Sheet

1. Adhere to substrate with Titebond GREENchoice Fast Grab FRP Construction, a freeze-thaw stable, nonflammable, high strength, water based adhesive that trowels on and allows approximately 20 minutes working time before firming.

2. Adhere to substrate with Sani-Seal™ Advanced Adhesive, a freeze-thaw stable, nonflammable, high strength, water based adhesive that trowels on and allows approximately 20 minutes working time before firming.

3.04 CLEANING

A. At completion of the installation, clean surfaces in accordance with the IPC clean-up and maintenance instructions.