

# Installation Instructions

## Fireline™ Water Guard® Fire Barrier Floor to Floor/Wall to Wall Inside Mount

### Health & Safety

When working with this product, fibers that come in contact with skin may cause temporary irritation



Ventilate work area if possible



Cover exposed skin when working with product



Wear goggles when working with this product



Rinse all exposed skin with cold water before washing



Waste should be disposed of according to local regulations

STORE AND INSTALL BLANKETS SUCH THAT THE PRODUCT REMAINS DRY.

### NOTES:

1. Verify that the structural gap and blockout dimensions are in conformance with submittal data before beginning installation. Certification of this product was completed by Guardian and Intertek Testing Laboratories. Product must be installed in accordance with these Installation Instructions.
  2. If job site specific conditions exist, these general installation instructions do not take place of an Engineering Evaluation if required. Any modifications made to the product without documented manufacturing direction will void the warranty.
  3. F520 Water Guard® Fire Barrier is delivered pre-assembled. Factory transitions/directional changes must be installed first.
  4. Clean Water Guard® of all debris prior to installing expansion joint cover. If expansion joint cover is not immediately installed, the Water Guard® must be protected from damage with a temporary cover (by others).
- TIP:** If blanket assembly appears to wide to install, compress the sides of blanket by laying it on its side and, using a protective wood board, apply foot pressure. This will allow the blanket to regain its intended shape.

IPC.1996/REV.7

JOINTMASTER® Expansion Joint Systems

inpro.com • 800.222.5556 • 262.679.9010

World Headquarters S80 W18766 Apollo Drive, Muskego, WI 53150 USA

Installation Hotline: 866.394.6776

**inpro**®

# Installation Instructions

## Fireline™ Water Guard® Fire Barrier Floor to Floor/Wall to Wall Inside Mount

### Figure 1- End Dam and Intermediate Installation (If Dams are not specified on project proceed to fig. 2)

1. Verify in field the spacing and location of each End Dam/Intermediate Dam.
2. Prior to installation, lay the Water Guard® flat and silicone the flap of the dam to the desired location on the Water Guard® blanket. Dam must be centered (width wise) on blanket. Caulk perimeter of flap including to back of the Dam.
3. Flap should be positioned towards the expected flow of water.
4. Allow silicone to cure per directions on the tube.
5. Install Water Guard® into joint. Fold the Dam such that the convex side is facing to expected flow of water.
6. Liberally apply silicone caulk at both sides of the perimeter of Dam. Ensure enough caulk is used to create a water tight seal at full perimeter, leaving no openings.

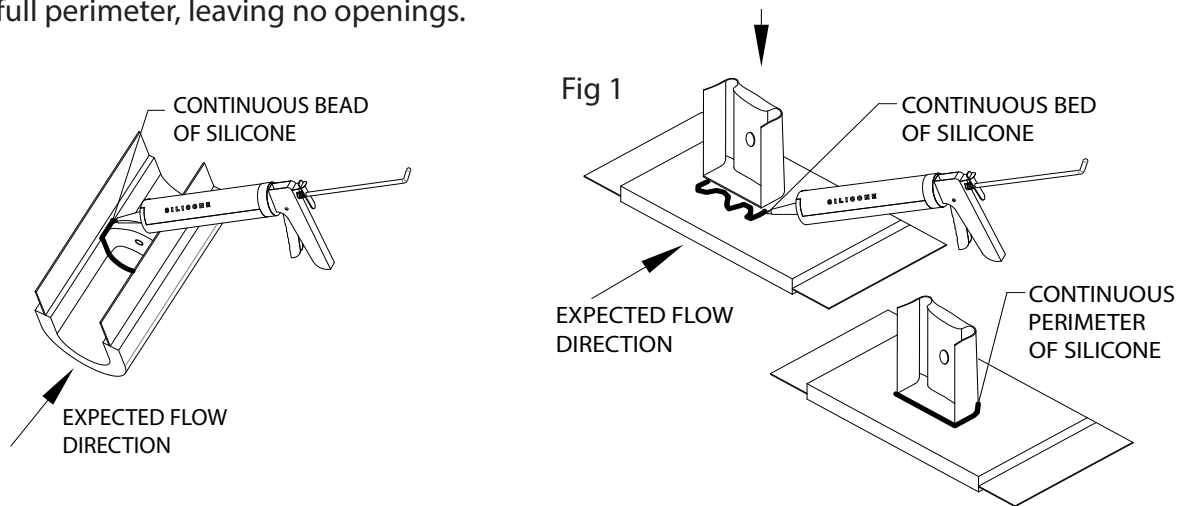

### Figure 2- Silicone Membrane Overlap Installation

7. Silicone has a recommended installation temperature range of -35°F (-37°C) to 140°F (60°C). Use discretion regarding installation of this product in extreme temperatures.
8. Apply a bead of silicone (provided by JointMaster) 1" (25mm) full width of the overlap and length.
9. Press the silicone membrane overlap on to the next section.
10. Apply another 1/2" (13mm) bead of silicone on the overlap seam and the next section.
11. Finally put a bead on the seam of the galvanized flanges.

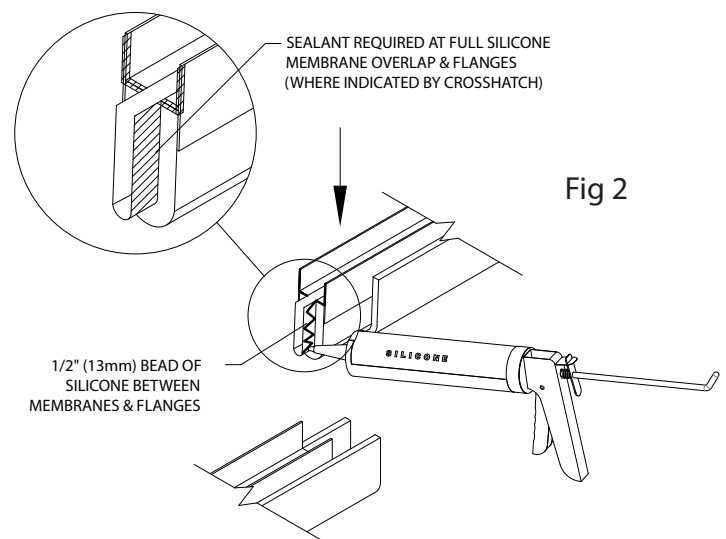

# Installation Instructions

## Fireline™ Water Guard® Fire Barrier Floor to Floor/Wall to Wall Inside Mount

### Figure 3- General Installation - Workflow

12. Apply a 1/2" (13mm) continuous bead or bed of substrate compatible sealant (supplied by others) underneath the flanges. The amount of sealant required will depend on the condition of substrate.
13. On the first section remove the male end and slide it into the wall. Install the next section, nesting the male into the female end tightly and secure the female with fasteners in each upper corner as depicted with hardware appropriate to the substrate.
14. Place the fire barrier into the expansion joint, F520 Fire Barrier has a 12" (305mm) overlap at each end. One end is the male and the other is the female. Always secure the female end with fasteners in each upper corner as depicted.
15. Flanges are galvanized metal. Ensure flanges are pressed tight and held flat to the substrate and silicone is fully engaged.
16. Utilize hardware appropriate to the substrate (supplied by others) with a maximum spacing of 12" (305mm) O.C. Examples of hardware for various conditions are:
  - Floor- Hilti# X-U 32 P8 S15 pin with washer x 1 1/4" (32mm) or 1/4" (6mm) x 1 1/4" (32mm) concrete/ wood screw with washer
  - Wall- Hilti# X-U 32 P8 S15 pin with washer x 1 1/4" (32mm) or Min 1/4" (6mm) x 1 1/4" (32mm) concrete/ self drilling screw with washer

Fig 3

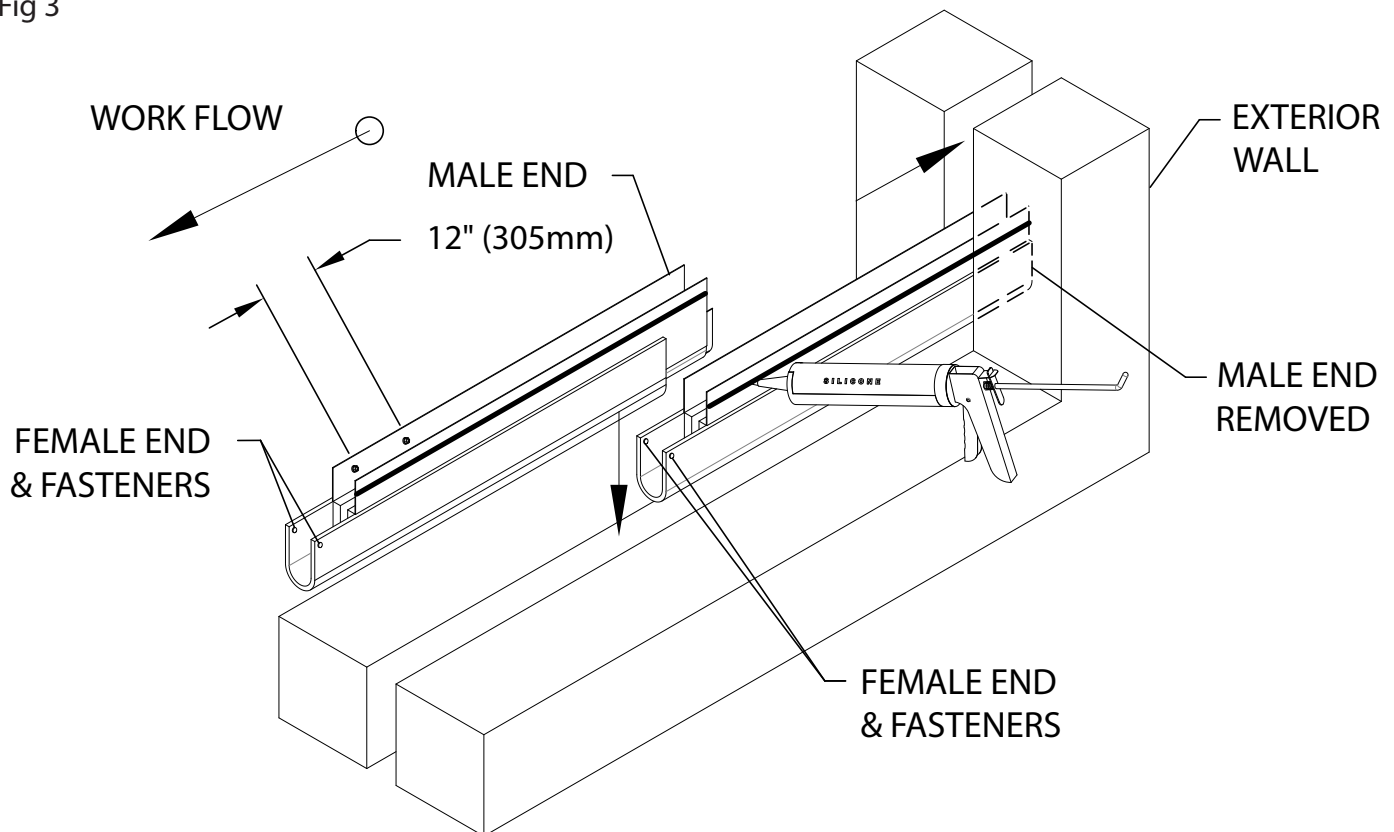

# Installation Instructions

## Fireline™ Water Guard® Fire Barrier Floor to Floor/Wall to Wall Inside Mount

### Figure 4- Continuous Horizontal Blanket With Vertical Termination (If Applicable)

17. Remove the male end of the fire barrier.

18. Next measure the depth of (Dim A) and the inside bellows (Dim B). Cut a "V" shape to match the space within the blanket.

19. Install the modified end into the throat of the floor and insert the fire barrier into the wall. Be sure there are no voids between the two. Fire caulk and silicone at connection point to ensure no air gap exists.

SEE FIG. 4a

19a. Once the vertical blanket has been successfully seated into the horizontal blanket and any voids have been fire caulked, seat a piece of silicone membrane as shown. Use the provided silicone caulk to seat the silicone membrane flashing. SEE FIG. 4b

Fig 4 TRANSITION INTERSECTION DETAIL

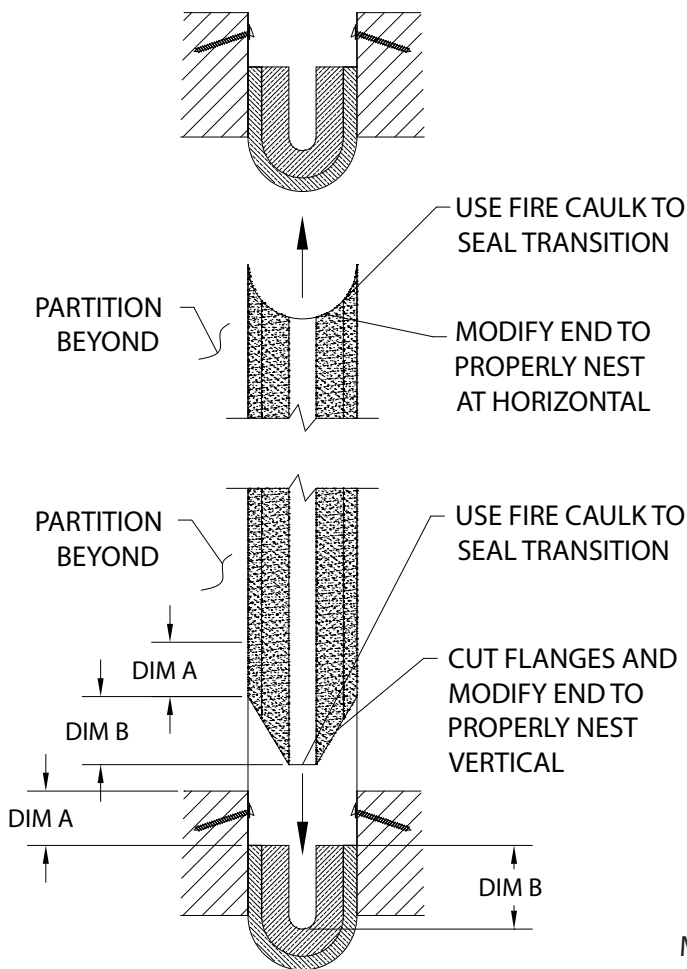

Fig 4a

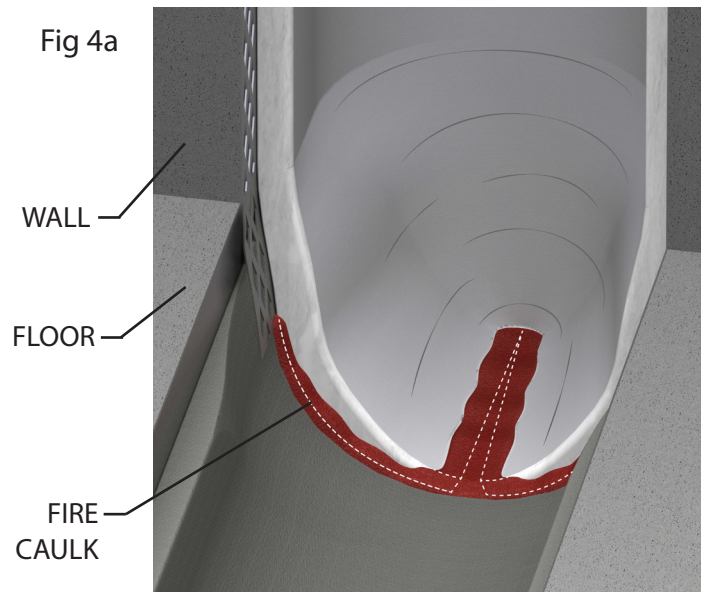
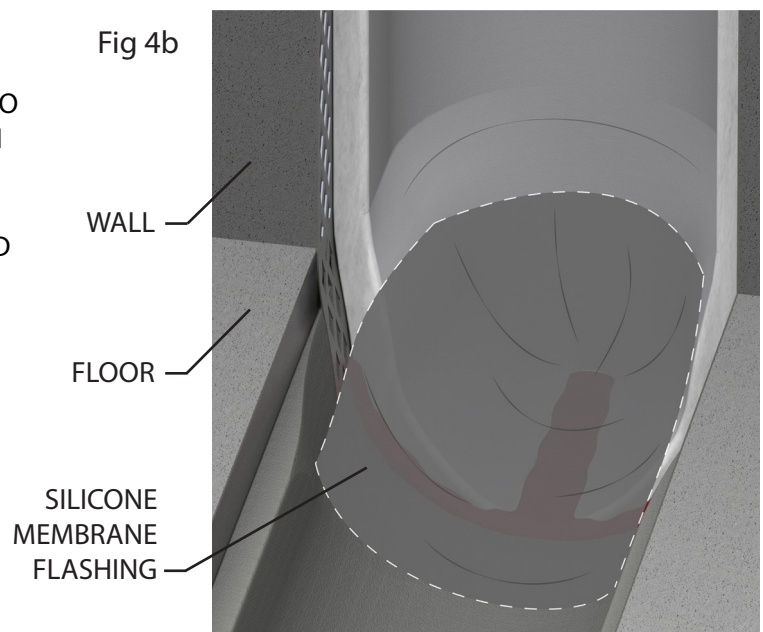

Fig 4b



# Installation Instructions

## Fireline™ Water Guard® Fire Barrier Floor to Floor/Wall to Wall Inside Mount

### Figure 5- Field Specific Lengths - Work Flow (If Applicable)

20. In the event a project requires a specific length, a female end can easily be recreated in the field to facilitate the next male end connection.

21. Measure the needed length from the edge of the flange to the other edge of the flange. Mark it on both sides.

22. Measure back 12" (305mm), using a razor remove the inside layer of white blanket material exposing the flanges (see Fig 6a). Remove the pins and cut the flanges off. The 1/2" (13mm) thick outer fire blanket will remain with the section.

23. In the female end install the 4 new pins/washers and bend the pins over.

24. Nest the 24" (610mm) male end into both female ends and fasten. Modify flanges to nest horizontal to fire blanket wall cavity to edge of slab.

Fig 5

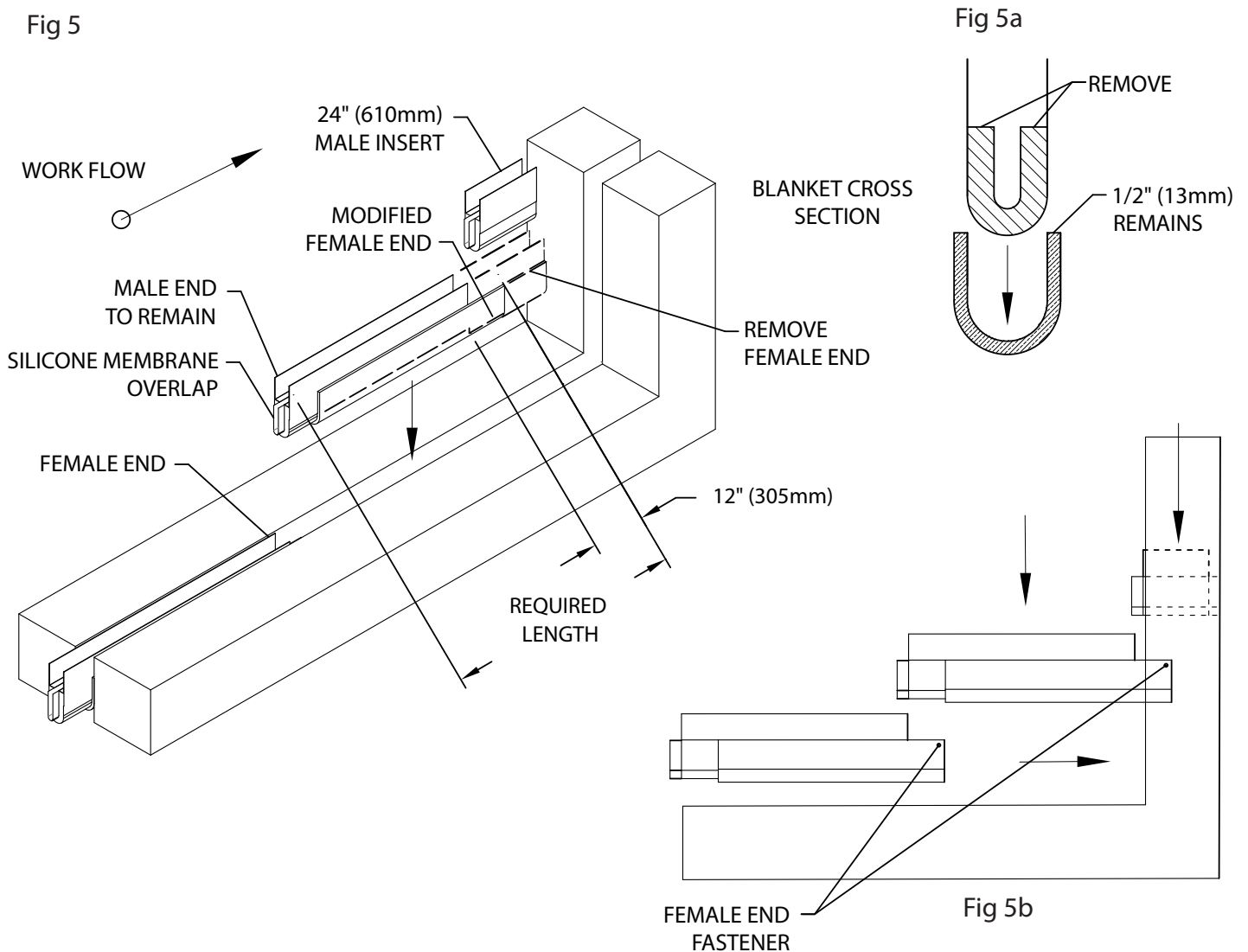

# Installation Instructions

## Fireline™ Water Guard® Fire Barrier Floor to Floor/Wall to Wall Inside Mount

### Figure 6 - Field Conditions Of Whole Fire Blanket Increments - Work Flow 4' (1.2m)

25. In these conditions you must remove the first male end and use it in the last female end. Cut silicone membrane such that end can be encapsulated with silicone caulk.
26. Remove the pins and cut the fire blanket in line with the edge of the flange. Set male end aside for later installation.
27. Install all the sections except for the last one.
28. Take the male end that is set aside and nest into the last female end.
29. Install the new pins/washers and bend the pins over.
30. Vacuum all debris from the fire barrier before the cover is installed.

Fig 6

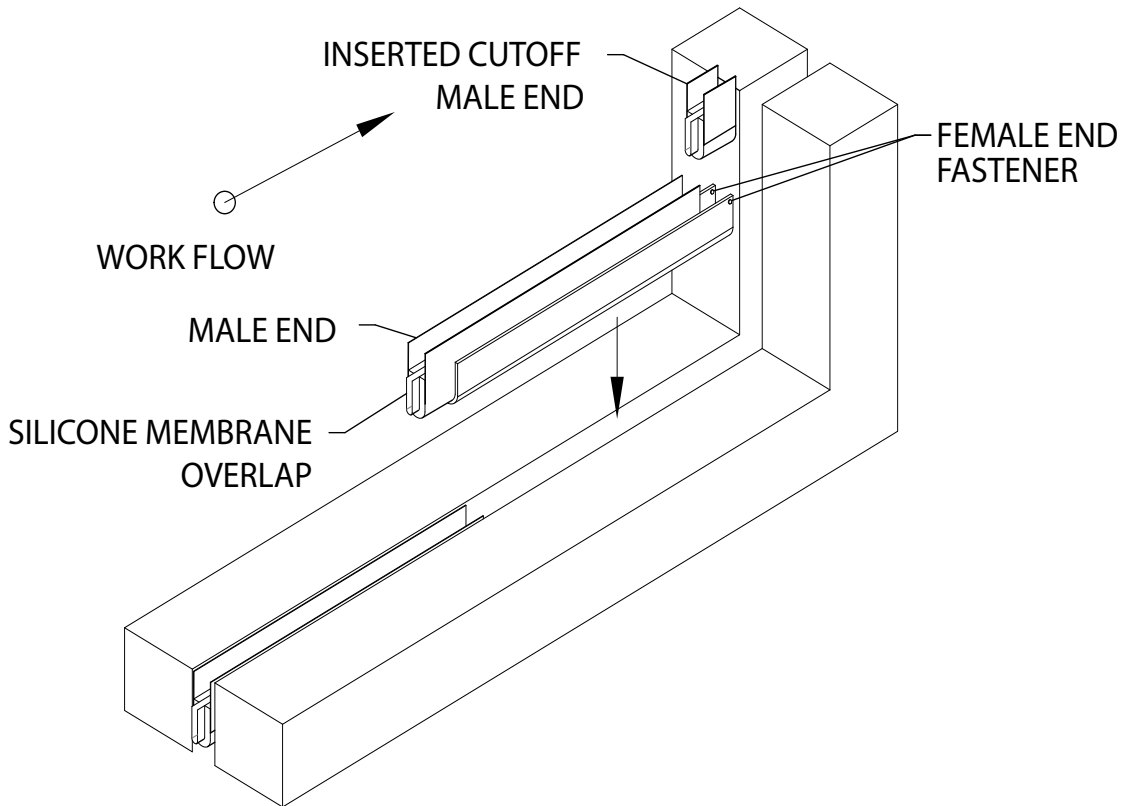

# Installation Instructions

## Fireline™ Water Guard® Fire Barrier Floor to Floor/Wall to Wall Inside Mount

### Figure 7 - Drain Connection

31. The optional drain is 1/2" (13mm) ID. Spacing to be determined prior to ordering by the Plumbing Engineer of record. The customer is responsible for drain attachment to project plumbing system.

32. Each drain tube is provided with a filter designed to prevent clogging. Ensure debris has been removed from Water Guard® blanket prior to the installation of the cover.

33. Filter to be installed, centered over the drain tube in the field. Install the filter with white silicone caulk (provided by Inpro) over the drain prior to installing the blanket assembly into the joint.

34. Adhere filter directly to the existing silicone cloth while the blanket system lies flat. Allow for the silicone caulk to cure before installing the blanket assembly into the joint.

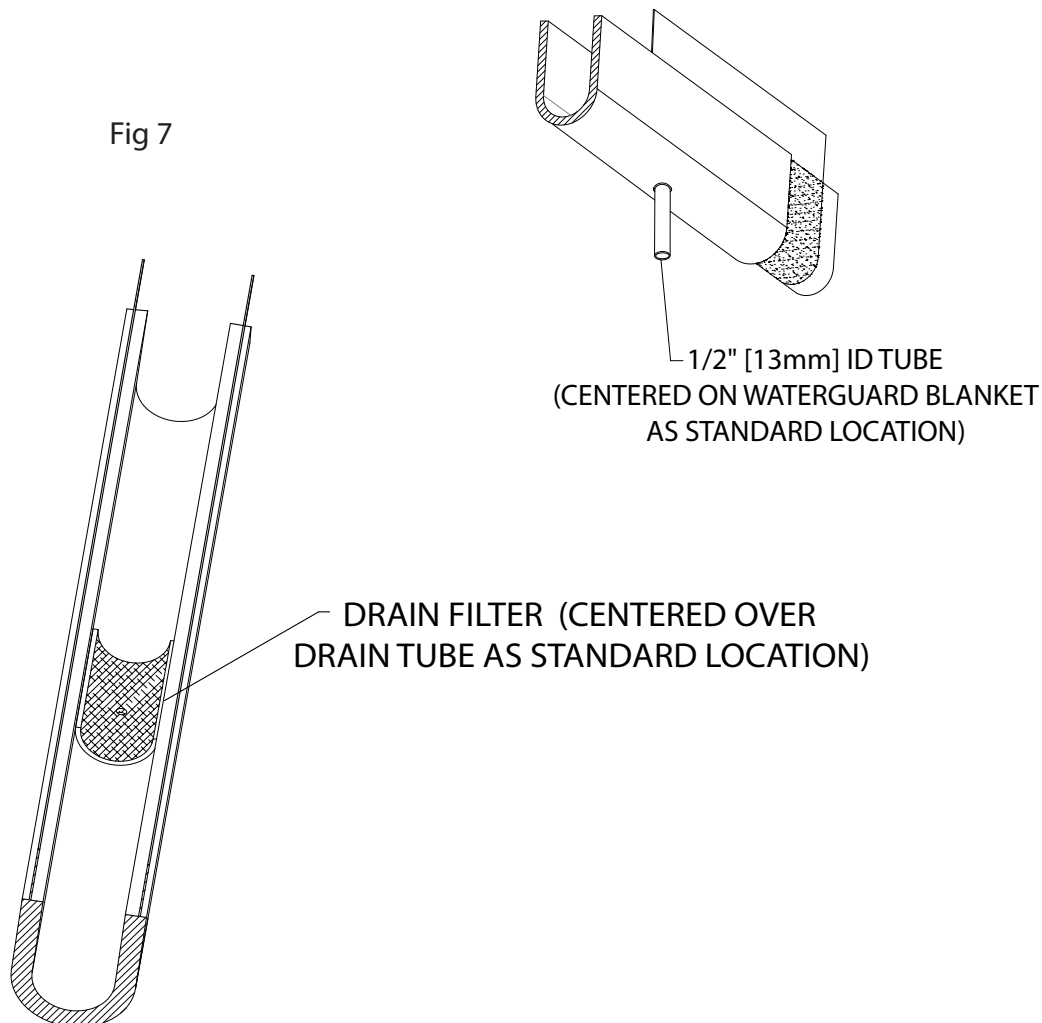

# Installation Instructions

## Fireline™ Water Guard® Fire Barrier Floor to Floor/Wall to Wall Inside Mount

### Figure 8 - Field Fabricated In-Plane 90 Deg Turn

35. Ensure the previously installed blanket has the female end towards the transition location.
36. Make blanket "A" by cutting next blanket to proper length making sure the measurement is taken from the male side of the blanket. This will be a straight cut through the blanket, avoiding the assembly pin locations. Use a utility knife to cut through blanket material and a tin snip or angle grinder for the flanges.
37. Install an end dam at the end of the blanket, on the end with the straight cut. See Figure 1 for install method of end dam.
38. Install blanket "A", ensuring the male end fits snugly into the female section and the butt end (with end dam) fits tightly into the corner of the directional change (Fig 8a). Install fire caulk at any visible openings, see tip below.
39. Install a temporary fastener affixing the "floating" flange to the substrate. This will need to be removed in a later step.
40. Use the remainder of the previously cut blanket assembly (if enough remains) to make blanket "B". Cut the butt end into an arch pattern (Fig 8b). Measure roughly 4" [102mm] back on the flanges to begin the cut. Blanket "B" should consist of an arch cut on one end and a female end on the other.
41. Install another end dam at the end of the blanket with the arch cut. See Figure 1 for install method of end dam.
42. Install blanket "B" into the corner, tightly pressing the end with the arch cut and end dam against the side wall of blanket "A". The arch cut should hug the side wall of blanket "A" snugly (Fig 8c). Install fire caulk at all visible openings at the seam, see tip below.
43. Remove the temporary fastener in step 39 and continue with installation of flashing over the transition.

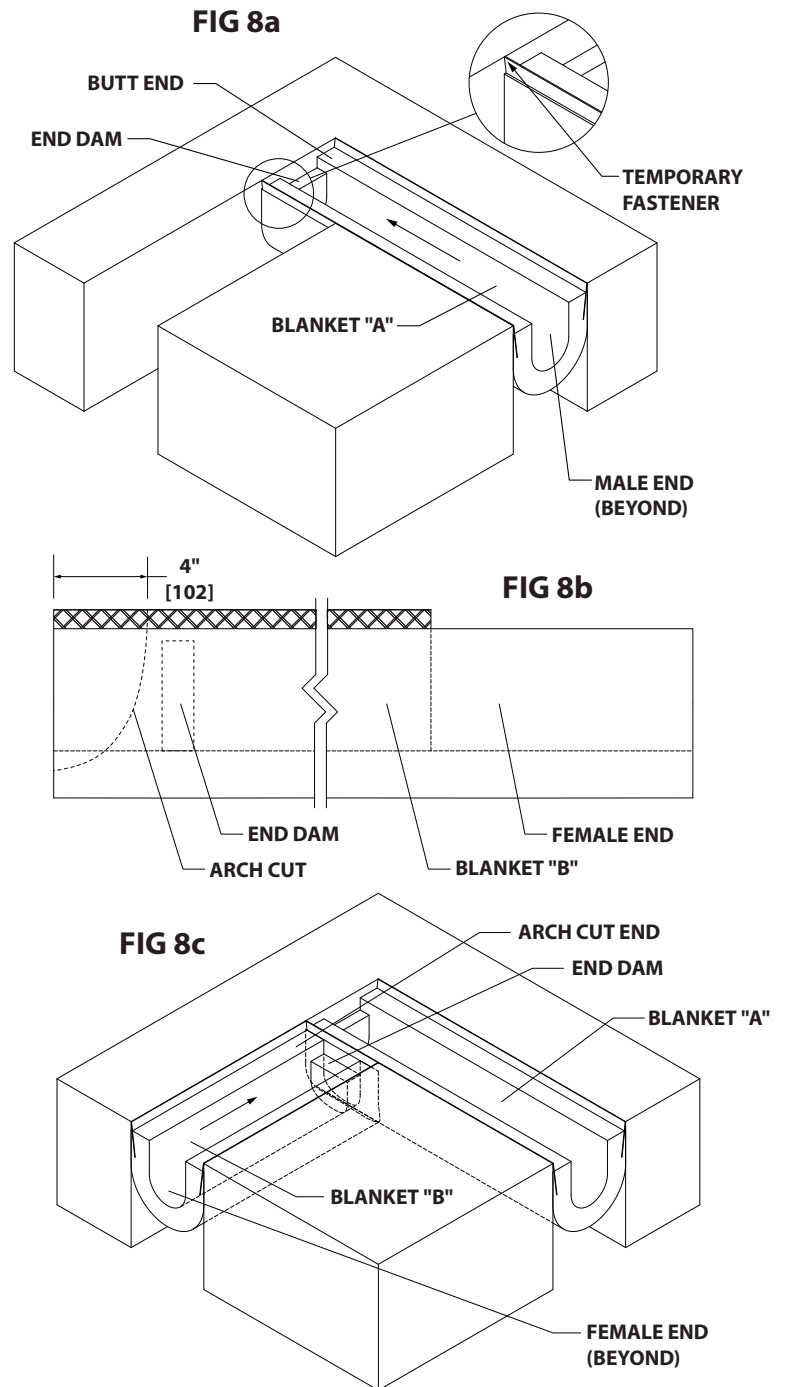

**FIRE CAULK TIP:** Apply fire caulk to the face of the butt end you are installing into the corner, and to the arch cut end you are installing against the other blanket. Then apply additional fire caulk at any visible openings.



# Installation Instructions

## Fireline™ Water Guard® Fire Barrier Floor to Floor/Wall to Wall Inside Mount

### Figure 9 - Flashing the Transition

44. Allow time for the applied fire caulk to cure. Read directions on fire caulk tube for cure times.
45. Cut a silicone cloth patch to the proper size to cover the area shown in Fig. 9a. Adhere the flashing patch in a bed of silicone caulk in the locations shown, making sure to tuck the extra material into the opening of the blanket. Silicone caulk supplied by Inpro.
46. Attach the flashing patch to the adjacent substrate with a term bar, cut to roughly 1/3 the joint opening and secure with fasteners.
47. Cut a second silicone cloth patch, reference Fig. 9b for sizing. Cut 4" [102mm] slits in the locations shown.
48. Fold the second flashing patch into a "Z" shape and silicone caulk the patch into place as shown in Fig 9c. Make sure to only adhere the "wings" of the folded flashing patch. The folded style allows for expansion during joint movement.
49. Tuck the remaining 4" [102mm] of material after the slits into the opening of the blanket, this does not need to be adhered.
50. Continue with the general installation as referenced in Fig. 1.

FIG 9a

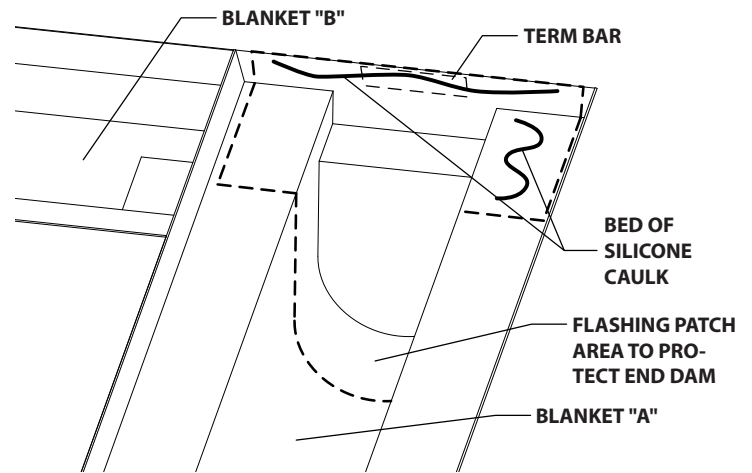

FIG9b

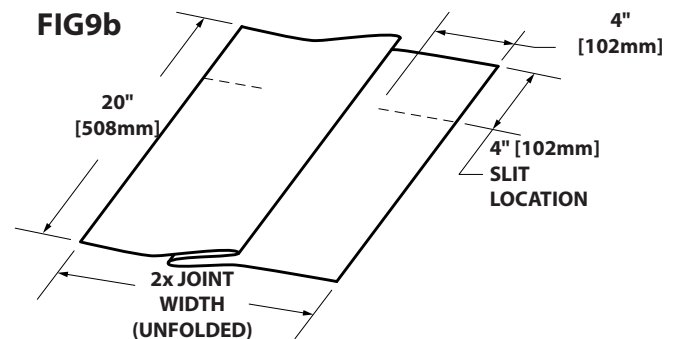

FIG 9c

