

EnviroGT G2-150

Corner Guard

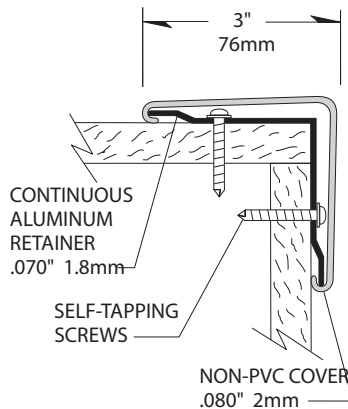

- Non-PVC cover is manufactured with G2 BioBlend™, InPro's exclusive blend of PETG and biopolymer
- Features a continuous aluminum retainer that has pre-slotted holes for quick installation
- 100 standard colors and 11 Global Colours to coordinate with your project
- Meets the most rigorous standards and criteria of chemical emissions as prescribed by the GREENGUARD Environmental Institute
- Has been tested and meets GREENGUARD Environmental Institute's and the state of California's requirements for low emitting products as tested by Air Quality Sciences
- Has been tested and meets the GREENGUARD Children & School chemical emissions levels



IPC.1136/REV.4

EnviroGT G2-150 Corner Guard

Suggested Specifications

PART 1 - GENERAL

1.01 SUMMARY

- A. Non PVC corner guard system for wall protection and decoration

1.02 SECTION INCLUDES

- A. G2-150 High Impact Corner Guard Systems

1.03 REFERENCES

- A. American National Standards Institute (ANSI)
B. American Society for Testing and Materials (ASTM)
C. National Fire Protection Association (NFPA)
D. Society of Automotive Engineers (SAE)

1.04 SYSTEM DESCRIPTION

- A. Performance Requirements: Provide corner guard systems that conform to the following requirements of regulatory agencies and the quality control of IPC Door and Wall Protection Systems, InPro Corporation.

1. Fire Performance Characteristics: Provide material conforming with the NFPA Class A fire rating. Surface burning characteristics, as determined by ASTM E-84, shall be flame spread of 25 or less and smoke development of 450 or less.
2. Impact Strength: Provide materials that have been tested in accordance with the applicable provisions of ASTM D-256, Impact Resistance of Plastics.
3. Chemical and Stain Resistance: Provide material that shows resistance to stain when tested in accordance with applicable provisions of ASTM D-543.
4. Fungal and Bacterial Resistance: Provide material that does not support fungal or bacterial growth as tested in accordance with ASTM G-21 and ASTM G-22.
5. GREENGUARD Certified: Provide GREENGUARD Certified material. Profiles shall meet the requirements of GREENGUARD Certification Standards for Low-Emitting Products and GREENGUARD Product Emission Standard for Children & Schools.
6. Color Consistency: Provide components matched in accordance with SAE J-1545 - (Delta E) with a color difference no greater than 1.0 units using CIE Lab, CIE CMC, CIE LCh, Hunter Lab or similar color space scale systems.

1.05 SUBMITTALS

- A. Product Data: Manufacturer's printed product data for each product indicated in this section.
B. Detail Drawings: Mounting details with the appropriate fasteners for specific project substrates.
C. Samples: Verification samples of corner guard, 8" (203mm) long, in full size profiles of each type and color indicated.
D. Manufacturer's Installation Instructions: Printed installation instructions for each corner guard.

1.06 DELIVERY, STORAGE AND HANDLING

- A. Deliver materials in unopened factory packaging to the jobsite
B. Inspect materials at delivery to assure that specified products have been received.

- C. Store in original packaging in a climate controlled location away from direct sunlight.

1.07 PROJECT CONDITIONS

- A. Environmental Requirements: Install products in an interior climate controlled environment.

1.08 WARRANTY

- A. Standard IPC Limited Lifetime Warranty against material and manufacturing defects.

PART 2 - PRODUCTS

2.01 MANUFACTURER

- A. Acceptable Manufacturer: IPC Door and Wall Protection Systems™, InPro Corporation, PO Box 406, Muskego, WI 53150, USA; Telephone: 800.222.5556, Fax: 888.715.8407, www.inprocorp.com
B. Substitutions: Not permitted
C. Provide all corner guard and wall protection from a single manufacturer.

2.02 LEED CRITERIA

- A. Provide corner guard systems with components that have recycled content.

1. MR Credit 4.1, 10%(post-consumer + ½ pre-consumer), 1 credit
2. MR Credit 4.2, 20%(post-consumer + ½ pre-consumer), 1 credit

2.03 MANUFACTURED UNITS

- A. Corner Guard Profile
1. G2-150 High Impact Corner Guard Profile
3" (76mm) x 3" (76mm), 90 degree
4' (1.22m), 8' (2.44m) and 9' (2.74m) 12'(3.66m) standard heights.

Options: Custom heights available.

2.04 MATERIALS

- A. G2 BioBlend™, a blend of PETG and biopolymer: Snap on cover of .080" (2mm) thickness shall be extruded from chemical and stain resistant G2 BioBlend™.
B. Aluminum: Continuous aluminum retainer of .070" (1.8mm) thickness shall be fabricated from 6063-T5 aluminum with a mill finish.

2.05 COMPONENTS

- A. Top Caps shall be made of injection molded thermoplastics.
B. Fasteners: All mounting system accessories appropriate for substrates indicated on the drawing shall be provided.

2.06 FINISHES

- A. Corner Guard Covers: Corner guard colors to be selected by the architect from the IPC finish selection.
B. Molded components: Top Caps shall be of a color matching the corner guards. Surface shall have a pebblette texture.

PART 3 - EXECUTION

3.01 EXAMINATION

- A. Examine areas and conditions in which the corner

guard system will be installed.

1. Complete all finishing operations, including painting, before beginning installation of corner guard system materials.
2. Wall surface shall be dry and free from dirt, grease and loose paint.

3.02 PREPARATION

- A. General: Prior to installation, clean substrate to remove dust, debris and loose particles.

3.03 INSTALLATION

- A. General: Locate corner guard as indicated on approved detail drawings for the appropriate substrate and in compliance with the IPC installation instructions. Install corner guard level and plumb at the height indicated on the drawings.

- B. Installation of G2-150 High Impact Corner Guard:

1. Position the aluminum retainer against the wall, allowing 5/16" (8mm) from the bottom of the aluminum to the top of the cove base or baseboard for the bottom cap.

2. Aluminum Retainer Installation

Drywall installation: Secure the aluminum retainer to the wall using 1-1/4" Phillips round head self-tapping screws. Use 4 screws per 6 screws per 4' (1.22m) length, 10 screws per 8' (2.44m) length, or 12 screws per 9' (2.74m) length. The aluminum retainer is pre-slotted to aid in the installation.

Concrete installation: Drill 1/4" holes into the ends of the retainer for top and bottom caps. Use the slotted tabs of the top caps as a template for hole location. Transfer the location of all mounting holes to the wall. Drill 1/4" (6.5mm) holes and position ALLIGATOR anchors into the holes on the wall. Mount the retainer with #10 x 1-3/4" Phillips pan head screws and tighten to secure the retainer to the wall.

3. Top and Bottom Cap Installation

Drywall installation: Overlap the aluminum with the mounting tabs of the top cap and attach them to the aluminum retainer using two, 1-3/4" Phillips flat head self tapping screws per cap.

Concrete installation: Overlap the aluminum with the mounting tabs of the top and bottom caps and attach them to the aluminum retainer using two, #8 x 1-1/2" Phillips flat head screws per cap.

4. Position the cover on the aluminum retainer to check the fit. Adjust the top cap on the aluminum retainer to obtain a tight fit with the cover. Starting at the top, push the cover over the aluminum, by pressing over the length until the cover snaps securely into place.

3.04 CLEANING

- A. At completion of the installation, clean surfaces in accordance with the IPC clean-up and maintenance instructions.