

EnviroGT G2-5000

Wall Guards

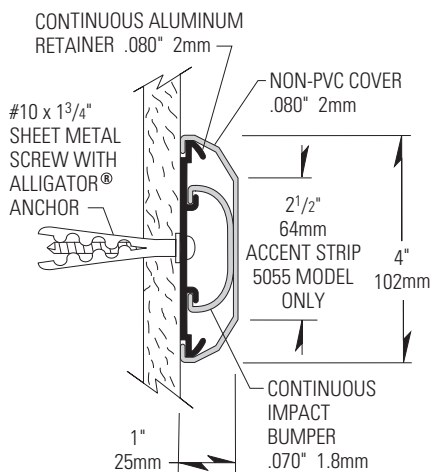

- Non-PVC cover is manufactured with BioPolyPETG+, InPro's exclusive reformulated PETG made with a corn-based biopolymer and recycled content; available in 100 standard colors and 11 Global Colours
- Unique, chiseled shape provides a sleek, innovative look
- Meets the most rigorous standards and criteria of chemical emissions as prescribed by the GREENGUARD Environmental Institute
- Has been tested and meets GREENGUARD Environmental Institute's and the state of California's requirements for low emitting products as tested by Air Quality Sciences
- Has been tested and meets the GREENGUARD Children & School chemical emissions levels



IPC.1171/REV.1

EnviroGT G2-5000 Wall Guard

Suggested Specifications

PART 1 – GENERAL

1.01 SUMMARY

- A. Non PVC Wall Guard system for wall protection and decoration

1.02 SECTION INCLUDES

- A. G2-5000 Wall Guard Systems

1.03 REFERENCES

- A. American National Standards Institute (ANSI)
B. American Society for Testing and Materials (ASTM)
C. National Fire Protection Association (NFPA)
D. Society of Automotive Engineers (SAE)

1.04 SYSTEM DESCRIPTION

- A. Performance Requirements: Provide wall guard systems that conform to the following requirements of regulatory agencies and the quality control of IPC Door and Wall Protection Systems, InPro Corporation.
1. Fire Performance Characteristics: Provide wall guard conforming with the NFPA Class A fire rating. Surface burning characteristics, as determined by ASTM E-84, shall be flame spread of 25 or less and smoke development of 450 or less.
2. Impact Strength: Provide materials that have been tested in accordance with the applicable provisions of ASTM D-256, Impact Resistance of Plastics.
3. Chemical and Stain Resistance: Provide material that shows resistance to stain when tested in accordance with applicable provisions of ASTM D-543.
4. Fungal and Bacterial Resistance: Provide material that does not support fungal or bacterial growth as tested in accordance with ASTM G-21 and ASTM G-22.
5. GREENGUARD Certified: Provide GREENGUARD Certified profiles. Profiles shall meet the requirements of GREENGUARD Certification Standards for Low-Emitting Products and GREENGUARD Product Emission Standard for Children & Schools.
6. Color Consistency: Provide components matched in accordance with SAE J-1545 - (Delta E) with a color difference no greater than 1.0 units using CIE Lab, CIE CMC, CIE LCh, Hunter Lab or similar color space scale systems.

1.05 SUBMITTALS

- A. Product Data: Manufacturer's printed product data for each product indicated in this section.
- B. Detail Drawings: Mounting details with the appropriate fasteners for specific project substrates.
- C. Samples: Verification samples of wall guard, 8" (203mm) long, in full size profiles of each type and color indicated.
- D. Manufacturer's Installation Instructions: Printed installation instructions for each wall guard.

1.06 DELIVERY, STORAGE AND HANDLING

- A. Deliver materials in unopened factory packaging to the jobsite
- B. Inspect materials at delivery to assure that specified products have been received.
- C. Store in original packaging in a climate controlled location away from direct sunlight.

1.07 PROJECT CONDITIONS

- A. Environmental Requirements: Install products in an

interior climate controlled environment.

1.08 WARRANTY

- A. Standard IPC Limited Lifetime Warranty against material and manufacturing defects.

PART 2 – PRODUCTS

2.01 MANUFACTURER

- A. Acceptable Manufacturer: IPC Door and Wall Protection Systems™, InPro Corporation, PO Box 406, Muskego, WI 53150, USA; Telephone: 800.222.5556, Fax: 888.715.8407, www.inprocorp.com
- B. Substitutions: Not permitted
- C. Provide all wall guard and wall protection from a single manufacturer.

2.02 LEED CRITERIA

- A. Provide wall guard systems with components that have recycled content.
1. MR Credit 4.1, 10%(post-consumer + ½ pre-consumer), 1 credit
2. MR Credit 4.2, 20%(post-consumer + ½ pre-consumer), 1 credit

2.03 MANUFACTURED UNITS

- A. Wall Guard Profile
1. G2-5000 Wall Guard, 4" (152mm) height x 1" (25mm) depth

2.04 MATERIALS

- A. Reformulated PETG with Biopolymer Blend: Snap on cover of .080" (2mm) thickness shall be extruded from chemical and stain resistant PETG. Inner snap-on impact bumper of .070" (1.8mm) thickness shall be extruded from chemical and stain resistant PETG.
- B. Aluminum: Continuous aluminum retainer of .080" (2mm) thickness shall be fabricated from 6063-T5 aluminum with a mill finish.

2.05 COMPONENTS

- A. End Caps, inside corners and outside corners shall be made of injection molded thermoplastics.
- B. Fasteners: All mounting system accessories appropriate for substrates indicated on the drawing shall be provided.

2.06 FINISHES

- A. Wall Guard Covers: Wall guard colors to be selected by the architect from the IPC finish selection. Color of the inner impact bumper to be black.
- B. Molded components: End Caps, inside corners and outside corners shall be of a color matching the wall guards. Surface shall have a pebble texture.

PART 3 – EXECUTION

3.01 EXAMINATION

- A. Examine areas and conditions in which the wall guard system will be installed.
1. Complete all finishing operations, including painting, before beginning installation of wall guard system materials.
2. Wall surface shall be dry and free from dirt, grease and loose paint.

3.02 PREPARATION

- A. General: Prior to installation, clean substrate to remove dust, debris and loose particles.

3.03 INSTALLATION

- A. General: Locate wall guard as indicated on approved detail drawings for the appropriate substrate and in compliance with the IPC installation instructions. Install wall guard level and plumb at the height indicated on the drawings.
- B. Installation of G2-5000 Wall Guard:
G2-5000 Wall Guard
Material must be stored, installed and used in environmentally controlled conditions.
1. Cut the wood retainer to the required length, allowing 15/16" (24mm) for end caps, 1/4" (6.5mm) for outside corners and 1-5/16" (33mm) for inside corners. Allow 1/16" (1.5mm) between the end caps/corners and the retainer for adjustments when attaching the cover.
2. Drill 5/16" (8mm) holes on the centerline of the mounting grooves of the wood retainer, 4" (102mm) from each end in a zigzag pattern and spaced evenly over the entire length (6 anchors per 12' (3.66m) length). If rubber spacers, are used attach them behind the retainer by putting the screw through the hole in the spacer (6 rubber spacers per 12' (3.66m) length). NOTE: If mounting on concrete or brick, drill 1/4" (6mm) holes, 3/8" (9.5mm) from each end of the retainer at the correct centerline location for end caps or corners.
3. Position and level the wood retainer on the wall, allowing for end caps and corners, and transfer the mounting holes to the wall with a marker. Drill 1/4" (6mm) holes at each mark and position the ALLIGATOR anchors into the holes on the wall. Mount the retainer with #10 x 1-3/4" Phillips pan head screws. If rubber spacers are used, attach them behind the wood retainer. When used, rubber spacers are required at all mounting holes, and behind end caps and corners.
4. Slide the end caps and corners onto the wood, leaving a 1/16" (1.5mm) gap for adjustments and secure them with two #10 x 3/8" Phillips pan head screws per end cap or four per corner.
5. Cut the cover to the distance between the end caps and corners. NOTE: Trim all factory edges square before installation. Position the cover on the wood retainer to check the fit. Adjust the end caps and corners, in order to obtain a tight fit with the cover. Position the cover on the retainer and push over the retainer until it snaps into place.

3.04 CLEANING

- A. At completion of the installation, clean surfaces in accordance with the IPC clean-up and maintenance instructions.