

# Installation Instructions

## IVB (Insulated Vapor Barrier)

Note: Verify that the structural gap and blockout dimension is in conformance with submittal data before beginning installation. If this is a Fire Rated Assembly, the fire barrier must be installed before the Architectural Joint System. Refer to the fire barrier / insulated vapor barrier instructions for specific system installation.

Figure 1

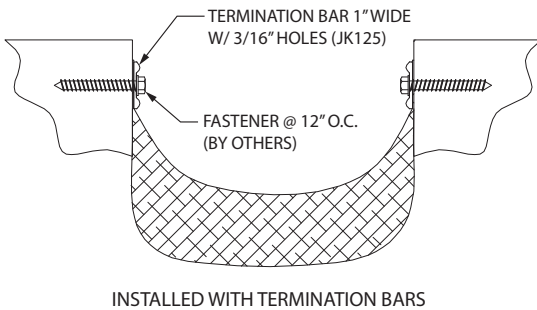
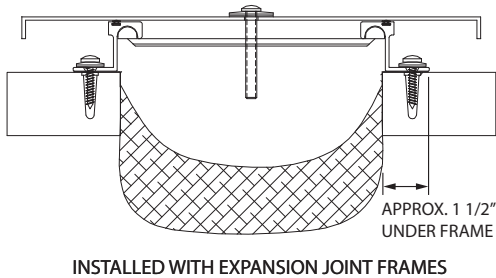
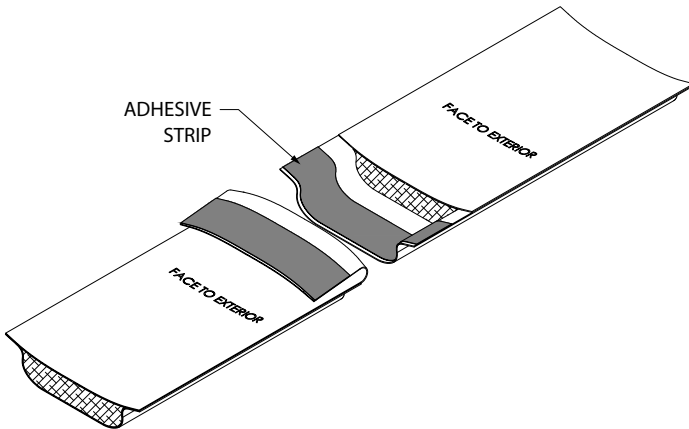

Figure 2



### Mounting

Before installing vapor barrier into joint system, pre-assemble section runs remembering to allow for extra length on each end. Clean ends with EPDM primer. (See Fig 2-6)

Figure 1

1. When installing insulated vapor barrier using expansion joint cover frames, place butyl caulk/EPDM tape (by others) against substrate free of dirt, oil and loose debris.

2. When installing insulated vapor barrier with termination bars, Place vapor barrier edges in butyl caulk/tape and secure with termination bar or base of expansion joint cover frame and use appropriate fastener (by others) for substrate.

### Seams

Figure 2

3. When butt joining sections together, prepare splicing area with EPDM primer (by others) and allow to dry.

4. Remove film from bottom adhesive strip.

IPC.1097 /REV.5

JOINTMASTER® Expansion Joint Systems

inpro.com • 800.222.5556 • 262.679.9010

World Headquarters S80 W18766 Apollo Drive, Muskego, WI 53150 USA

Installation Hotline: 866.394.6776

**inpro**®

# Installation Instructions

## IVB (Insulated Vapor Barrier)

Figure 3

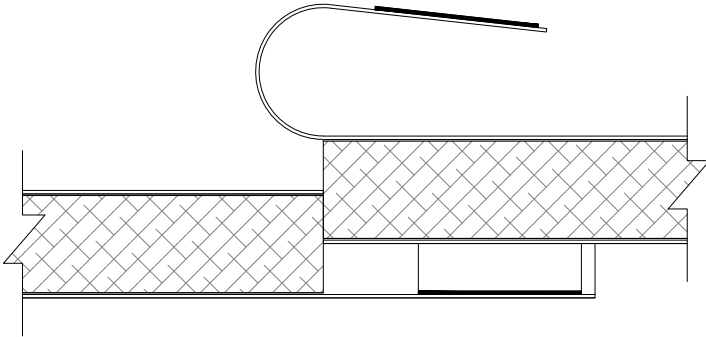

Figure 3

4. Ensure the butt ends of both mating sections are snug against each other.

5. Attach sections together pressing firmly where the adhesive strip attaches to the mating section.

Figure 4

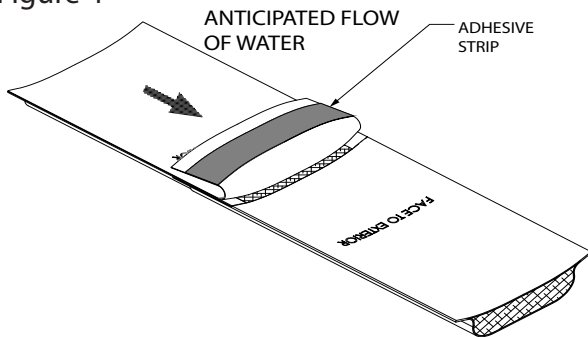
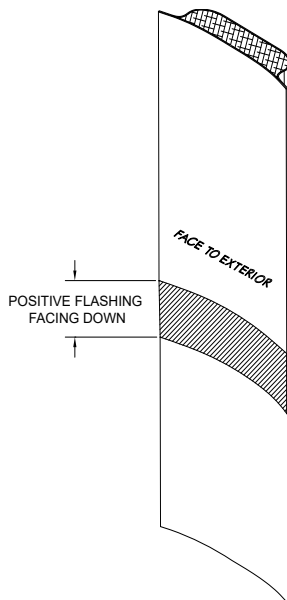

Figure 4

6. Prime surface where adhesive strip will contact EPDM surface.

7. Remove protective coating from adhesive strip on top sheet, and attach to mating section.

8. Once splice is complete, apply pressure with hand roller to area ensuring the adhesive strips are uniformly adhered and form a water tight seal.



# Installation Instructions

## IVB (Insulated Vapor Barrier)

Figure 6

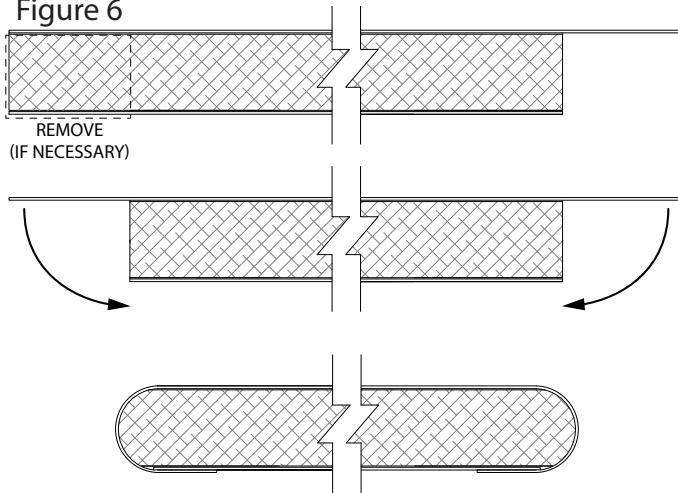

### End Caps

Figure 6

9. Once run section is the proper length remove 6" of material from ends underneath the top sheet to create flaps to seal end section.

10. Apply adhesive sealant to underside of flaps and fold over end condition. Seal the flanged edges and any open areas with adhesive to ensure a watertight seal.

Figure 7

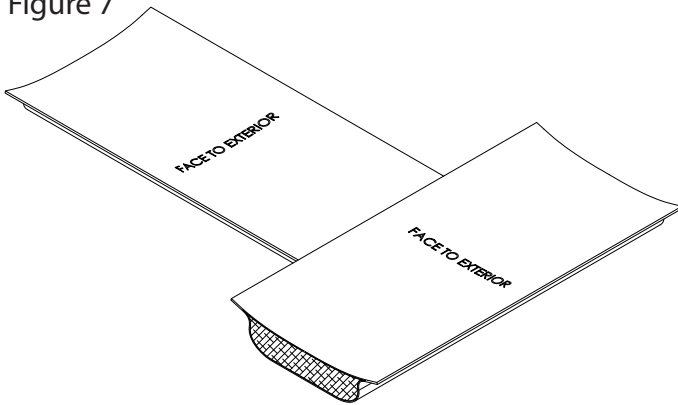

### Transitions

Figure 7

11. At intersections, terminate blanket per figure 6. Create butt splice as shown in figure 7.

Figure 8

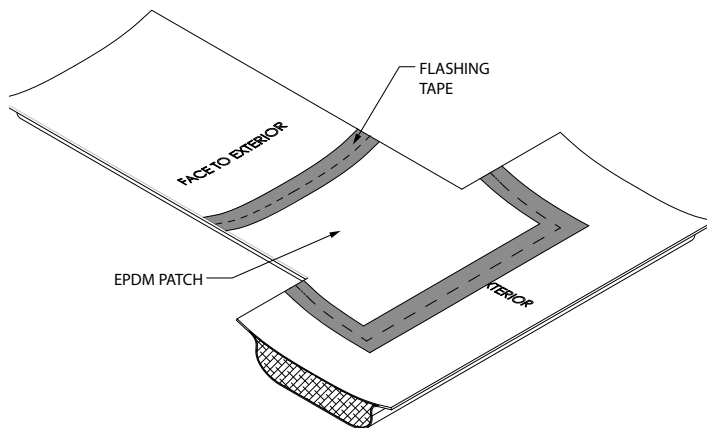

Figure 8

12. Using supplied EPDM sheet, cut a transitional patch which will fit over the entire seam created by the intersection. Ensure EPDM sheet flashing is captured by the frames or termination bar.

13. Apply EPDM patch to the intersection. Overlap seams with flashing tape (by others).

# Installation Instructions

## IVB (Insulated Vapor Barrier)

---

Figure 9

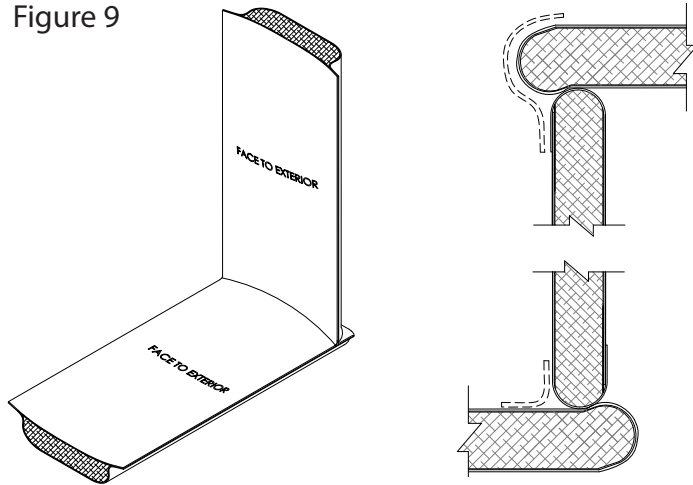

Figure 9

14. At transitions where vertical and horizontal runs intersect, always run the horizontal segment past the vertical segment.

15. Clean with EPDM primer. Install EPDM peel and stick flashing over joint min. 4" (102mm) both directions.

Figure 10

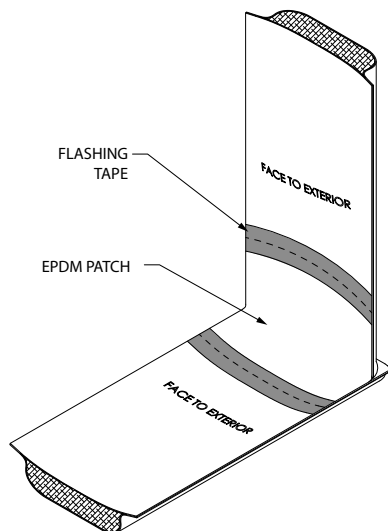

Figure 10

16. Using supplied EPDM sheet, cut a transitional patch which will fit over the entire seam created by the intersection. Ensure EPDM sheet flashing is captured by the frames or termination bar.

17. Attach double stick adhesive to edges of patch and apply to the intersection. Overlap seams with flashing tape.