

# Installation Instructions

## JOS-TrStp

Read all installation instructions before installing product. If retrofitting a parking area, always use cones, barrels or other means to secure the area and alert motorists.

Fig.1

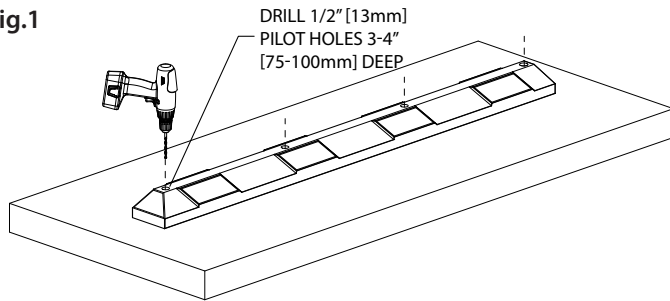

Fig.2

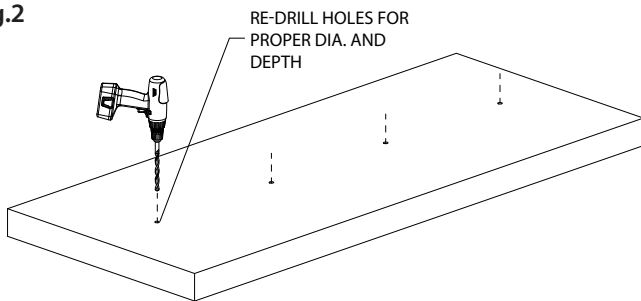

Fig.3

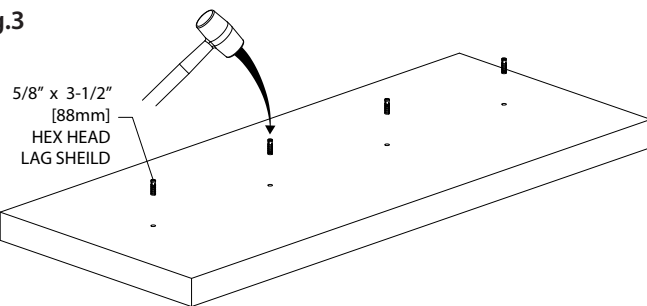

Fig.4

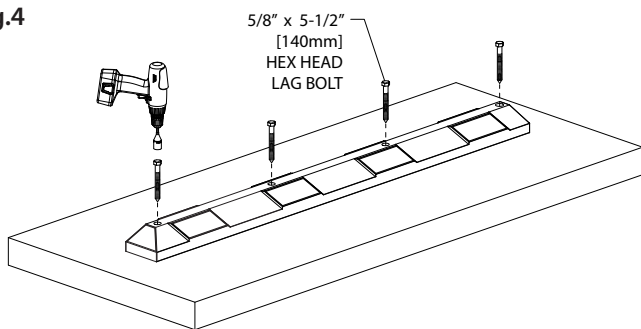

Figure 1

1. Position tire stop at the proper location to be installed. Using pre-made holes, drill pilot holes using 1/2" [13mm] dia. drill bit. Drill the pilot holes to be 3-4" [75-100mm] deep.

Figure 2

2. Remove the tire stop; re-drill the pilot holes for the diameter and depth required by the supplied metal shields.

Figure 3

3. Using a 10 lb. hammer (or similar) drive supplied metal shields (Hardware pack JK181) into the drilled holes, until the head of the shield is flush with driving surface.

Figure 4

4. Return tire stop to position over the installed metal lag shields and secure in place using the supplied 5/8" x 5-1/2" [140mm] hex head lag screws (Hardware pack JK181).

IPC.1613/REV.1