

L-Shaped Folding Bench Seat Installation Instructions

Please read all instructions before installing products

Local codes vary from state to state. Check your local codes before installing the L-Shaped Folding Bench Seat. Consult the ADA Standards for any ADA Compliant installs.

FIG.1

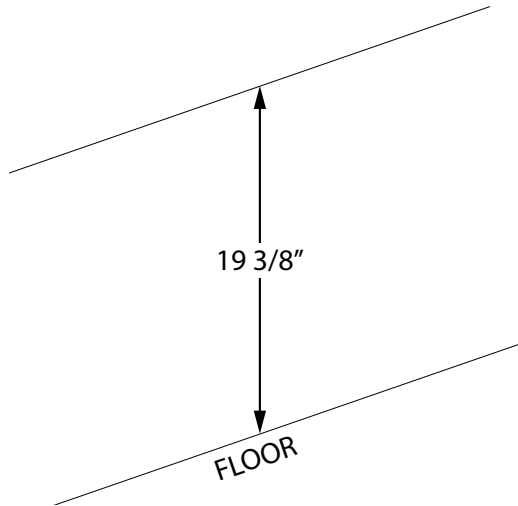

FIG.2

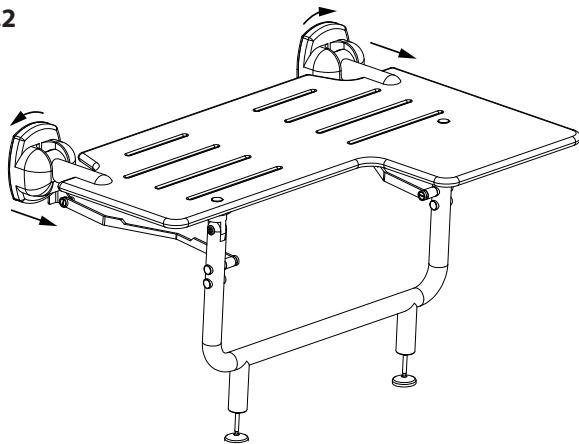
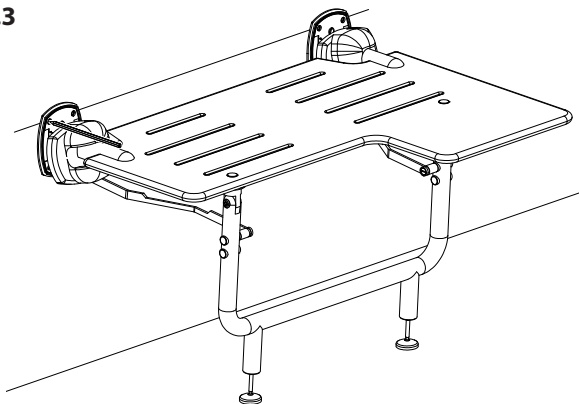

FIG.3



Note:

- Install bench seats into solid wall sub-structure or backing plates.
 - These instructions are intended for wood stud walls and/or blocking. If wall conditions vary use fasteners suitable for the wall conditions on which the product will be installed.
1. Using a level, draw a line on the wall, 19 3/8" above the floor, where the L-Shaped Folding Seat will be installed. *See Figure 1.*
 2. Remove the Folding Bench Seat from the box and place on a flat surface.
 3. Unclip the hinge covers, slide them back towards the bench top and rotate them 90° to the outside. *See Figure 2.*
 4. Position the bench seat against the wall with the top mounting holes lined up with the line on the wall and place a mark at each hole location. *See Figure 3.*
 5. Drill 7/32" pilot holes 2 1/2" deep into the wall at each hole location. *See Figure 4.*

Note: If installing onto wall cladding such as BioPrism® or tile, holes slightly larger than the fastener are needed through the wall cladding to prevent damage to the wall cladding.

FIG.4

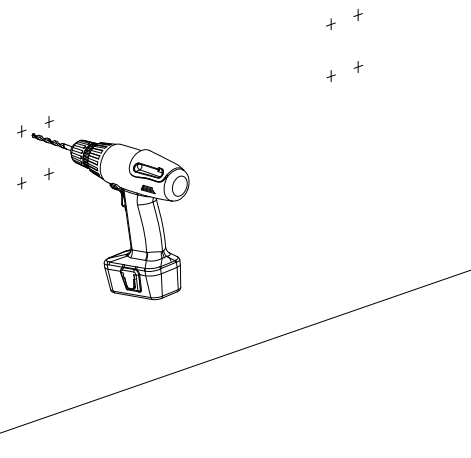

IPC.3098/REV.1

ENDURANT® Washroom Systems

inpro.com • 800.222.5556 • 262.679.9010

World Headquarters S80 W18766 Apollo Drive, Muskego, WI 53150 USA

Installation Hotline: 866.394.6776

inpro®

L-Shaped Folding Bench Seat Installation Instructions

FIG.5

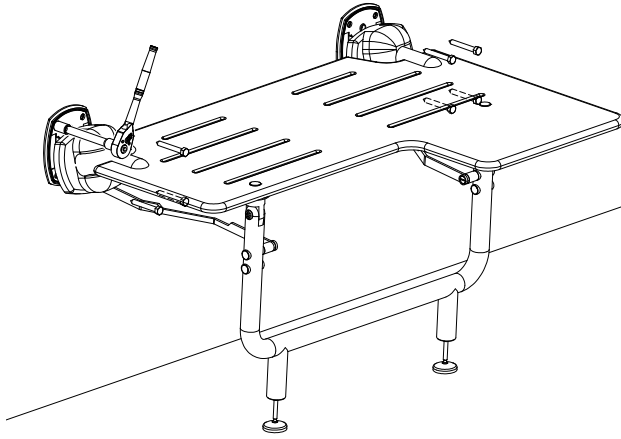

6. Attach the L-Shaped Folding Bench Seat to the wall with the provided M8 x 70mm lag screws and a 13mm socket. *See Figure 5.*

Caution: Hand tighten mounting bolts to avoid damaging wall cladding. DO NOT TIGHTEN WITH POWER TOOLS.

7. Slide the hinge covers down the frame and rotate them inwards 90°. Snap them into place on the wall plates. *See Figure 6.*
8. Rotate the bench down into its finished position.
9. Adjust the feet up or down to the desired height, the seat should tilt back approximately 1-2°. Once the feet are adjusted tighten the jam nut with a 19mm combination wrench. *See Figure 7.*

FIG.6

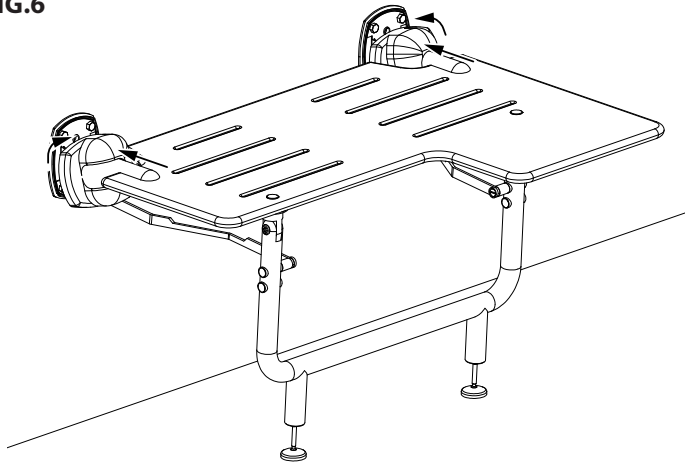
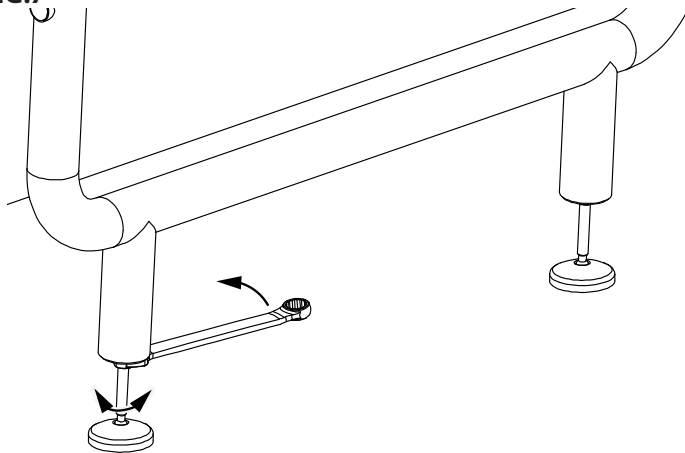

FIG.7



ENDURANT® Washroom Systems

inpro.com • 800.222.5556 • 262.679.9010

World Headquarters S80 W18766 Apollo Drive, Muskego, WI 53150 USA

Installation Hotline: 866.394.6776

inpro®