

Installation Instructions

Prism™ Solid Surface Partition Trim

- See shop drawings for trim locations.
- For the PARTIAL TRIM package, trim is not applied inside the stalls.
- Trim will need to be trimmed/notched around brackets/hardware for proper fitment.
- Notch trim with a rotary cutting tool such as a dremel or hand held router.
- If screw heads interfere with the fitment of the trim, use a router to create clearance for the screw heads.
- Install trim after all partition panels and hardware have been installed.

FIG. 1

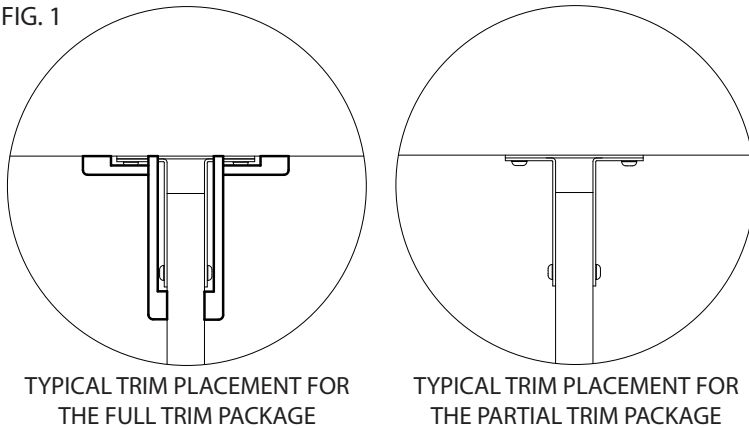

TYPICAL TRIM PLACEMENT FOR THE FULL TRIM PACKAGE

TYPICAL TRIM PLACEMENT FOR THE PARTIAL TRIM PACKAGE

FIG. 2

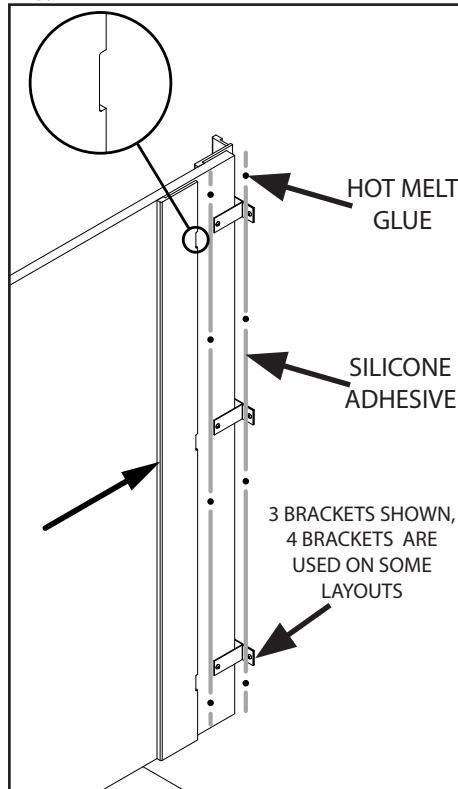

TRIM FOR TWO EAR BRACKETS

1. See Figure 1 for typical trim placement on two ear brackets.
2. For the full trim package follow the below steps, for the partial trim package skip to the next bracket type.
3. Test fit the bigger L-Shaped trim piece. Notch the trim piece where it intersects the wall brackets, so it fits tight up against the wall. *See Figure 2.*
4. Clean all mating surfaces with denatured alcohol.
5. Apply 3/8" beads of silicone where the trim contacts the wall and wall panel. *See Figure 2.*
6. Apply small pea sized drops of hot melt glue where the trim contacts the wall and wall panel. *See Figure 2.*
7. Press the trim into place and hold for 60 seconds or until the hot melt glue cures.

IPC.3122/Rev.3

ENDURANT® Washroom Systems

inpro.com • 800.222.5556 • 262.679.9010

World Headquarters S80 W18766 Apollo Drive, Muskego, WI 53150 USA

Installation Hotline: 866.394.6776

inpro®

Installation Instructions

Prism™ Solid Surface Partition Trim

FIG. 3

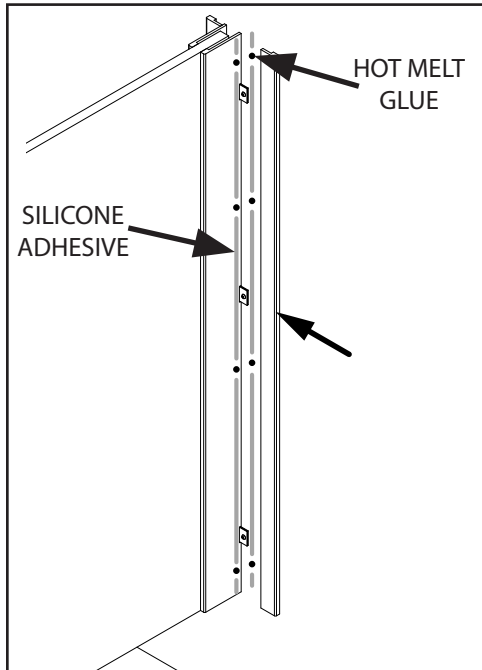
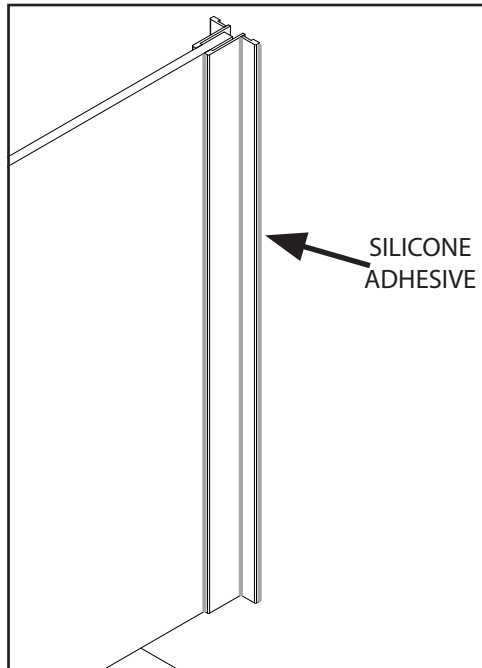

FIG. 4



8. Test fit the smaller L-Shaped trim piece.
9. Clean all mating surfaces with denatured alcohol.
10. Apply 3/8" beads of silicone where the trim contacts the wall and the previous trim piece. *See Figure 3.*
11. Apply small pea sized drops of hot melt glue where the trim contacts the wall and previous trim piece. *See Figure 3.*
12. Press the trim into place and hold for 60 seconds or until the hot melt glue cures.
13. Apply silicone to the perimeter of where the trim pieces meet the wall, the wall panel, and each other. *See Figure 4.*

Note:

If you are using pick resistant color coordinated caulk (FastFill) please refer to the FastFill Installation Addendum.

14. Clean up excess silicone with denatured alcohol and a clean rag.
15. Repeat this process on the opposite side of the wall panel.

Installation Instructions

Prism™ Solid Surface Partition Trim

FIG. 5

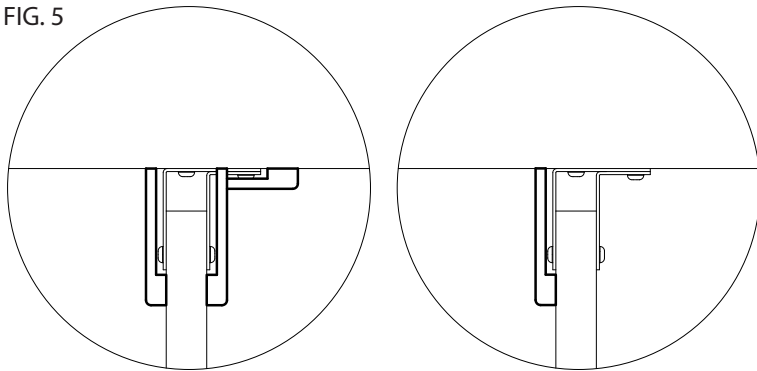

TYPICAL TRIM PLACEMENT FOR THE FULL TRIM PACKAGE

TYPICAL TRIM PLACEMENT FOR THE PARTIAL TRIM PACKAGE

FIG. 6

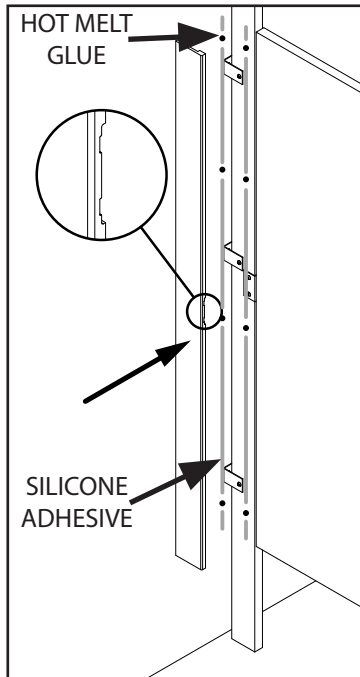
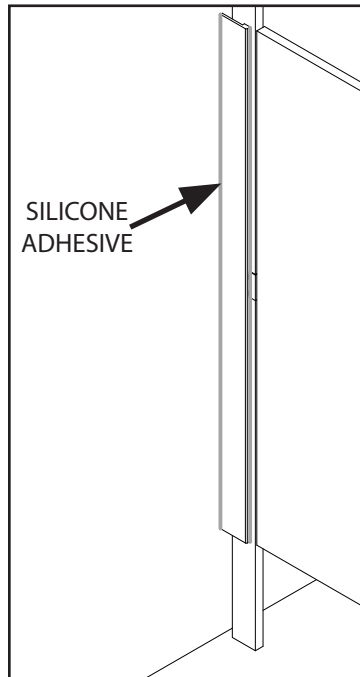

FIG. 7



TRIM FOR ONE EAR BRACKETS

1. See Figure 5 for typical trim placement on one ear brackets.
 2. Test fit the L-Shaped trim piece for the outside of the pilaster. Notch the trim piece where it contacts any brackets or hardware so it fits tight up against the wall. *See Figure 6.*
 3. Clean all mating surfaces with denatured alcohol.
 4. Apply 3/8" beads of silicone where the trim contacts the wall and pilaster. *See Figure 6.*
 5. Apply small pea sized drops of hot melt glue where the trim contacts the wall and wall panel. *See Figure 6.*
 6. Press the trim into place and hold for 60 seconds or until the hot melt glue cures.
 7. Apply silicone to the perimeter of where the trim piece meet the wall and the pilaster. *See Figure 7.*
- Note:**
If you are using pick resistant color coordinated caulk (FastFill) please refer to the FastFill Installation Addendum.
8. Clean up excess silicone with denatured alcohol and a clean rag.

FIG. 8

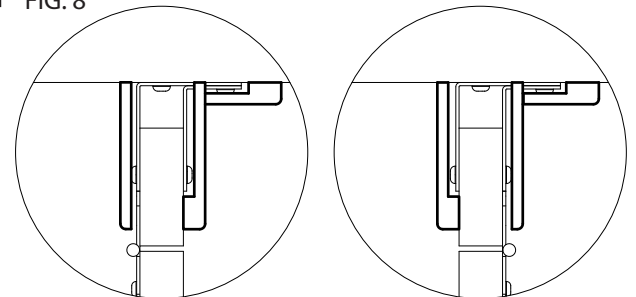

ALTERNATE TRIM
OUTSWING

ALTERNATE TRIM
INSWING

ALTERNATE TRIM

Some layouts, which use a door attached to a 3" pilaster, will need alternate trim. The longer L-Shaped trim piece on the hinge side is replaced by a Flat trim piece. *See Figure 8.*

Installation Instructions

Prism™ Solid Surface Partition Trim

FIG. 9

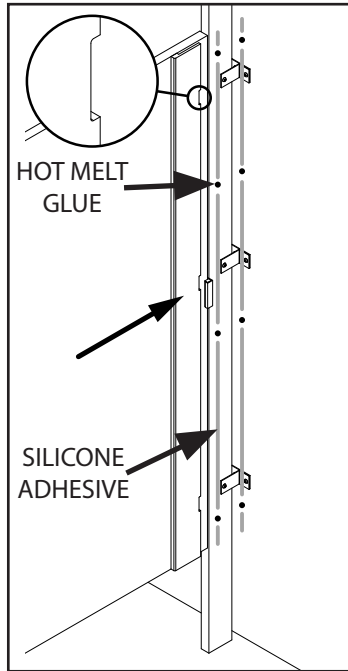

FIG. 10

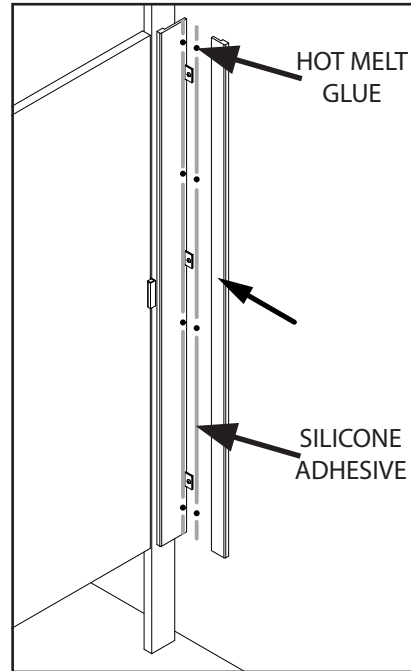
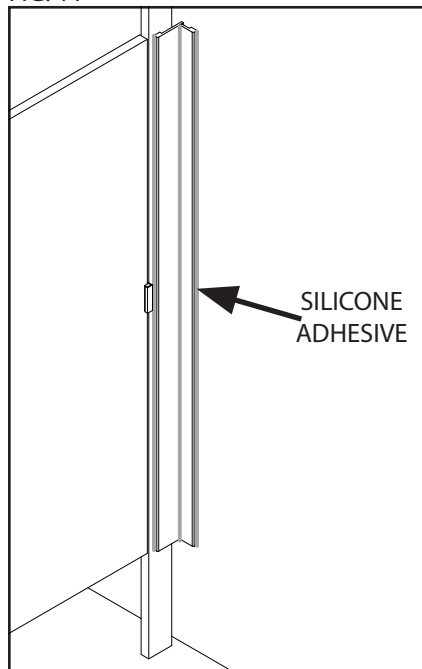

FIG. 11



If you are using the full trim package continue below, if you are using the partial trim package skip to the next section.

9. Test fit the bigger L-Shaped trim piece. Notch the trim piece where it intersects the wall brackets, so it fits tight up against the wall. *See Figure 9.*
 10. Clean all mating surfaces with denatured alcohol.
 11. Apply 3/8" beads of silicone where the trim contacts the wall and wall panel. *See Figure 9.*
 12. Apply small pea sized drops of hot melt glue where the trim contacts the wall and wall panel. *See Figure 9.*
 13. Press the trim into place and hold for 60 seconds or until the hot melt glue cures.
 14. Test fit the smaller L-Shaped trim piece.
 15. Clean all mating surfaces with denatured alcohol.
 16. Apply 3/8" beads of silicone where the trim contacts the wall and the previous trim piece. *See Figure 10.*
 17. Apply small pea sized drops of hot melt glue where the trim contacts the wall and previous trim piece. *See Figure 10.*
 18. Press the trim into place and hold for 60 seconds or until the hot melt glue cures.
 19. Apply silicone to the perimeter of where the trim pieces meet the wall, the wall panel, and each other. *See Figure 11.*
- Note:**
If you are using pick resistant color coordinated caulk (FastFill) please refer to the FastFill Installation Addendum.
20. Clean up excess silicone with denatured alcohol and a clean rag.

Installation Instructions

Prism™ Solid Surface Partition Trim

FIG. 12

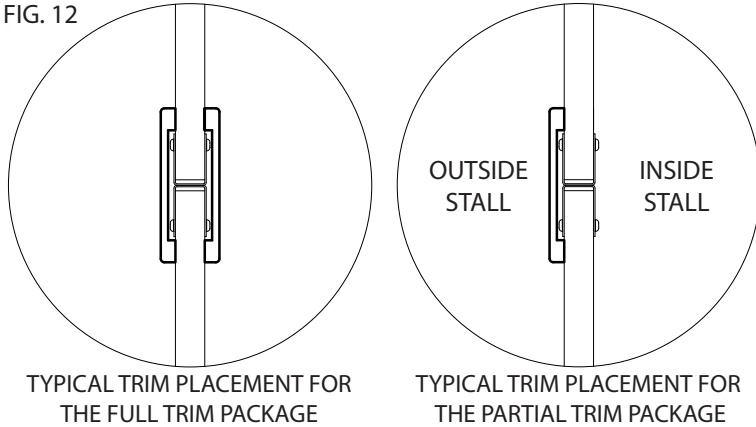

TRIM FOR H-BRACKETS

1. See Figure 12 for typical trim placement on H-Brackets.
2. Test fit the U-Shaped trim piece over the H-bracket on the outside of the stall.
See Figure 13.
3. Clean all mating surfaces with denatured alcohol.
4. Apply 3/8" beads of silicone where the trim contacts the wall panel and pilaster.
See Figure 13.
5. Apply small pea sized drops of hot melt glue where the trim contacts the wall and wall panel. *See Figure 13.*
6. Press the trim into place and hold for 60 seconds or until the hot melt glue cures.
7. Apply silicone to the perimeter of where the trim piece meet the pilaster and wall panel. *See Figure 14.*

FIG. 13

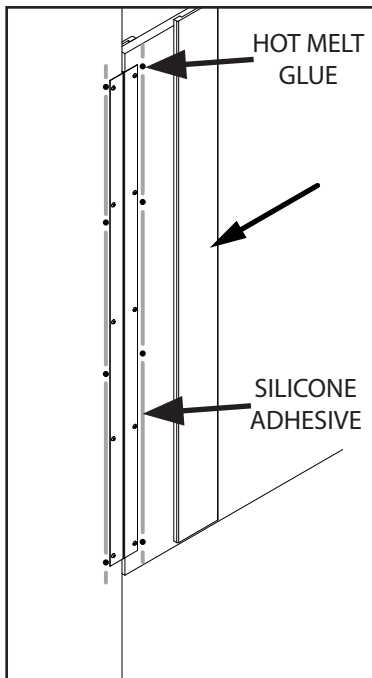
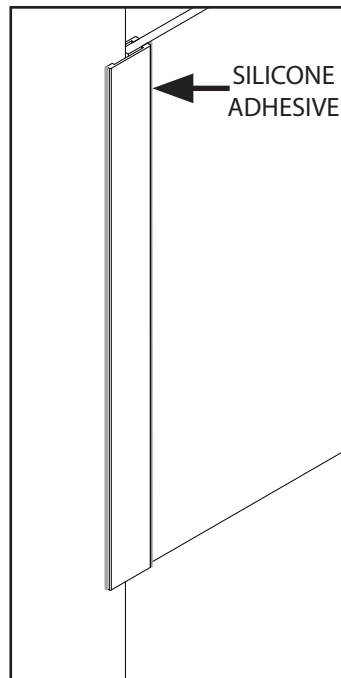

FIG. 14



Note:

If you are using pick resistant color coordinated caulk (FastFill) please refer to the FastFill Installation Addendum.

8. Clean up excess silicone with denatured alcohol and a clean rag.
9. If you are using the full trim package repeat on the opposite face of the pilaster and wall panel, inside the stall.

Installation Instructions

Prism™ Solid Surface Partition Trim

FIG. 15

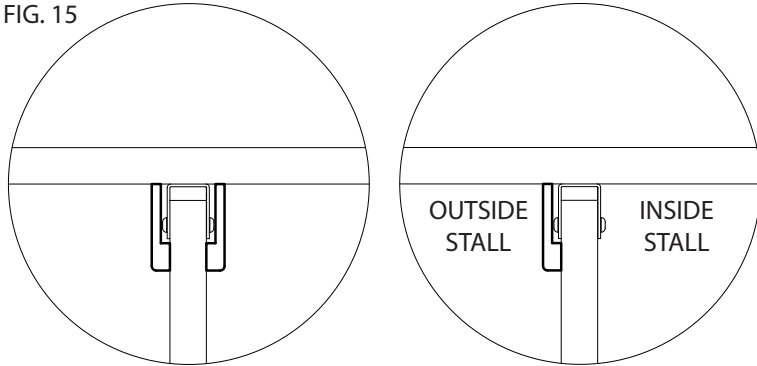

TYPICAL TRIM PLACEMENT FOR THE FULL TRIM PACKAGE

TYPICAL TRIM PLACEMENT FOR THE PARTIAL TRIM PACKAGE

FIG. 16

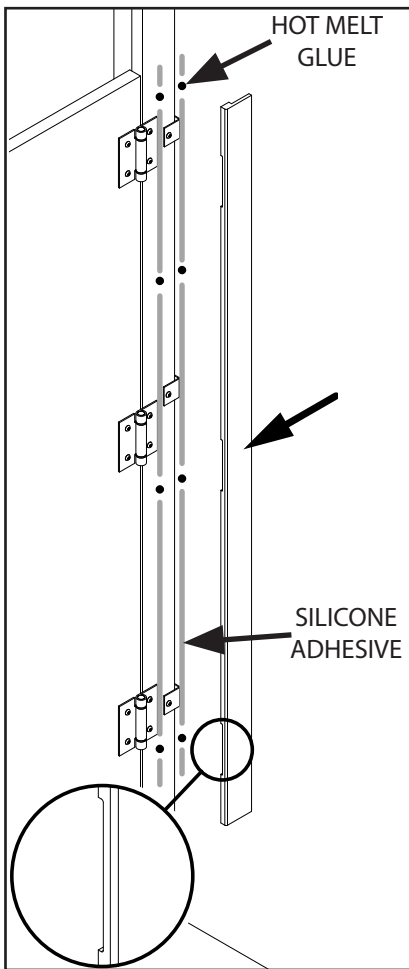
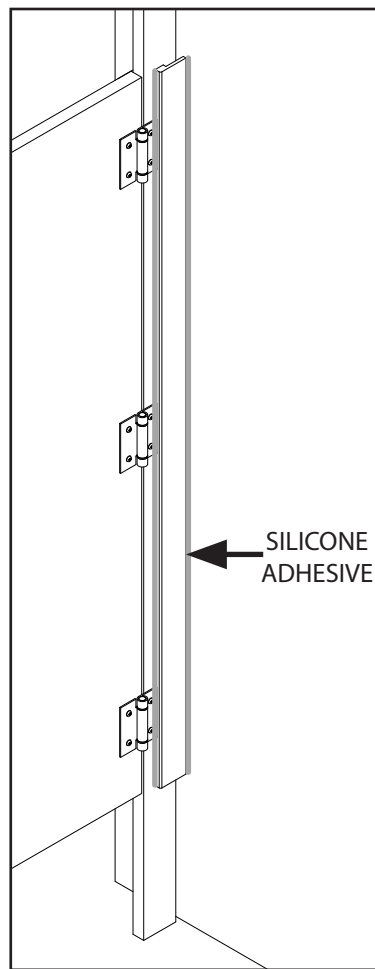

FIG. 17



TRIM FOR U-BRACKETS

1. See Figure 15 for typical trim placement on U-Brackets.
 2. Test fit the L-Shaped trim piece for the outside of the pilaster. Notch the trim piece where it contacts any brackets or hardware so it fits tight up against the wall. *See Figure 16.*
 3. Clean all mating surfaces with denatured alcohol.
 4. Apply 3/8" beads of silicone where the trim contacts the wall panel and pilaster. *See Figure 16.*
 5. Apply small pea sized drops of hot melt glue where the trim contacts the wall panel and pilaster. *See Figure 16.*
 6. Press the trim into place and hold for 60 seconds or until the hot melt glue cures.
 7. Apply silicone to the perimeter of where the trim piece meet the wall panel and the pilaster. *See Figure 17.*
- Note:**
If you are using pick resistant color coordinated caulk (FastFill) please refer to the FastFill Installation Addendum.
8. Clean up excess silicone with denatured alcohol and a clean rag.
 9. If you are using the using the full trim package repeat on the opposite face of the pilaster, inside the stall.

Installation Instructions

Prism™ Solid Surface Partition Trim

FIG. 18

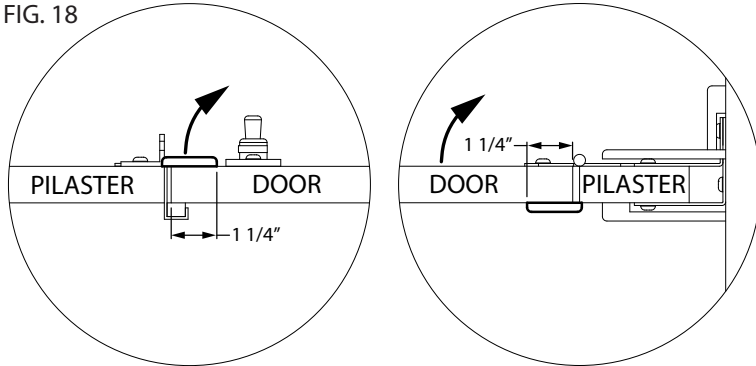

TYPICAL TRIM PLACEMENT FOR LATCH SIDE OF DOORS

TYPICAL TRIM PLACEMENT FOR HINGE SIDE OF DOORS

FIG. 19

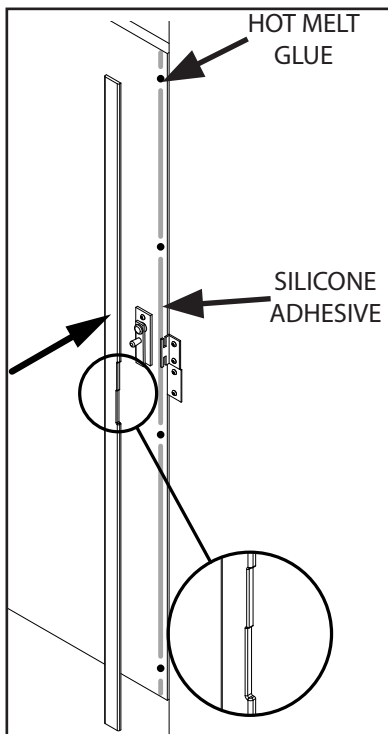

FIG. 20

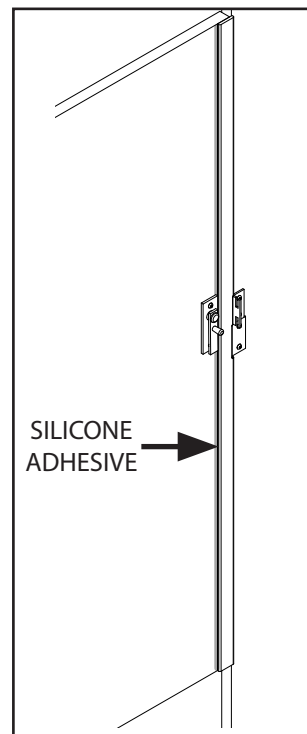
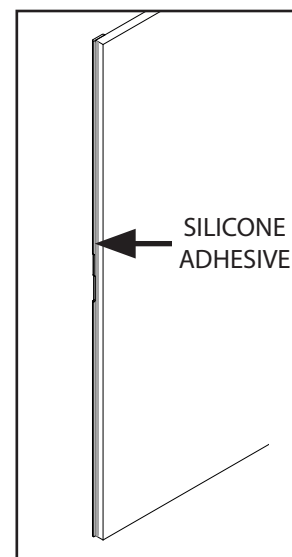

FIG. 21



TRIM FOR DOOR GAPS

1. See Figure 18 for typical trim placement on doors.
 2. Test fit the trim piece on the door. Notch the trim piece where it contacts any brackets or hardware so it fits tight up against the door. *See Figure 19.*
 3. Clean all mating surfaces with denatured alcohol.
 4. Apply 3/8" beads of silicone where the trim contacts the door. *See Figure 19.*
 5. Apply small pea sized drops of hot melt glue where the trim contacts the door. *See Figure 19.*
 6. Press the trim into place and hold for 60 seconds or until the hot melt glue cures.
 7. Apply silicone to the perimeter of where the trim piece meet the door. *See Figures 20 & 21.*
- Note:**
If you are using pick resistant color coordinated caulk (FastFill) please refer to the FastFill Installation Addendum.
8. Clean up excess silicone with denatured alcohol and a clean rag.