

# Prism™ Solid Surface Installation Instructions Toilet Partitions

Please read all instructions before installing products.

These instructions are intended for use with InPro's "standard" toilet partitions, which include 58" high doors and wall panels, when deviating from the standard product, Inpro may supply a supplement to these instructions.

**Please refer to the shop drawings provided by Inpro® for hardware placement and counts.**

**All hardware is sold in kits which include the appropriate fasteners.**

## Recommended Tool List

- Tape Measure
- Electric or battery-powered drill
- Drill bits (1/4", 17/64", 15/64", 5/16", 3/8", 7/16" for concrete/masonry)
- T-27 Pin-in head Torx driver
- 6" or 12" (spacer depending on wall panel height)
- Level
- Laser Level
- Chalk Line
- Miter saw
- Adjustable wrench
- Caulk Gun

Height	Bracket QTY
less than 64"	3 Brackets & Hinges
64" and up	4 Brackets & Hinges

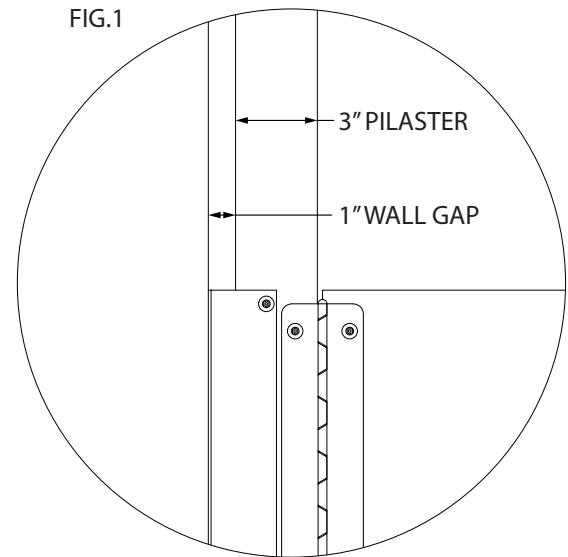

**APPLY SILICONE TO ALL HOLES DRILLED INTO THE PILASTERS, DOORS, WALL PANELS, OR URINAL SCREENS, BEFORE HARDWARE IS INSTALLED, TO PREVENT MOISTURE DAMAGE.**

## Tips from the Pros:

When installing a 3" pilaster with a continuous hinge, pay close attention to the wall gap. Deviating from a 1" wall gap, as noted in the shop drawings, will cause hinge fitment issues. (See Figure 1.)

When calculating distances to center lines -- pilasters, panels, and doors are all 1" (25.4mm) thick.

Do not drill holes at an angle. Make sure to drill perpendicular to material.

Pilot Holes should be 15/64" (6.0mm) diameter and drilled approximately 1/4" (6.4mm) deep.

Through-drilled holes should be 1/4" (6.4mm) diameter. Drill completely through material. Do not drill through brackets.

In-wall bracing is not furnished by InPro® Corporation. Confirm adequate structural support exists in walls prior to installation.

Where ceiling mount is required, structure in ceiling is not furnished by InPro® Corporation. Actual mounting system, including additional structural bracing, if required, must be designed by the architect or structural engineer, and furnished by others.

IPC.1328/REV.11

ENDURANT® Washroom Systems

inpro.com • 800.222.5556 • 262.679.9010

World Headquarters S80 W18766 Apollo Drive, Muskego, WI 53150 USA

Installation Hotline: 866.394.6776

**inpro®**

# Prism™ Solid Surface Installation Instructions Toilet Partitions

## Step 1 - Drilling Holes for Pilaster Floor Anchors (See Figure 2A.)

1. Using the layout drawings (supplied by InPro®) and a tape measure, confirm actual room dimensions.
2. Determine physical layout of parts in relationship to the room. If there is a discrepancy, please contact your InPro® sales rep at 800-222-5556.
3. Using the layout drawing as your guide, mark the center lines for pilasters and panels on the floor where they meet the structural walls. Since walls in the room may not be square, confirm layout dimensions parallel to the back wall with those measured from the perpendicular side walls.  
**Tip:** All parts are 1" (25.4 mm) thick.
4. Once measurements and layout has been confirmed, snap a chalk line between marks, made in the previous step, to mark partition center lines on the floor.
5. Starting from the side wall, measure and mark all hole drilling locations for pilaster anchors.  
**Tip:** There are two holes per anchor—the distance between the two holes is always 1-1/2" [38.1 mm]. There will be two "Floor Brackets" for pilasters 8" and larger, the brackets should be evenly spaced (See Figure 2B).

## Step 2 - Install Pilaster Floor Anchors (See Figure 2B.)

1. Drill a 5/16" (7.9mm) holes to 2" (50.8mm) minimum depth.
2. Blow out all dust inside hole.
3. Insert plastic anchor into hole. Using a hammer, gently tap the anchor into the hole until it reaches full depth.
4. Position floor bracket over anchors.
5. Insert pin-in torx screws and secure floor bracket.
6. To compensate for pitched floors, peel and stick red Silicone Rubber shims onto top of screw heads to desired height. Shims are 1/4" (6.4mm) thick and fit inside the floor bracket, use as necessary.

FIG. 2A

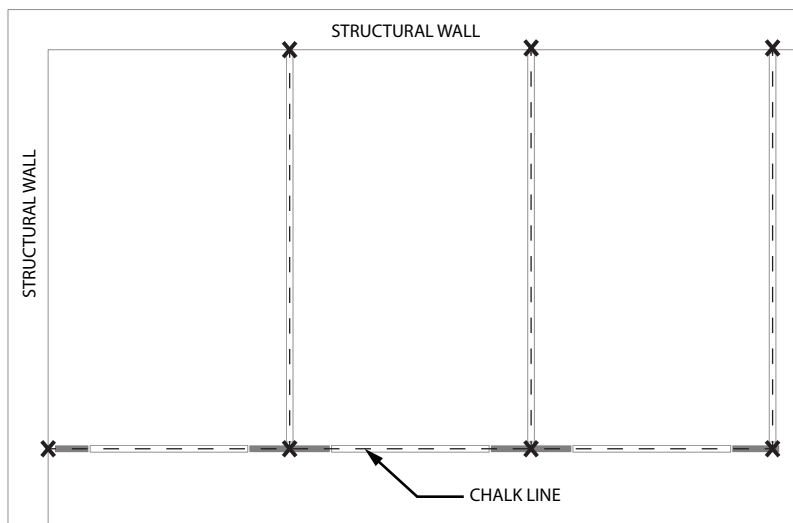
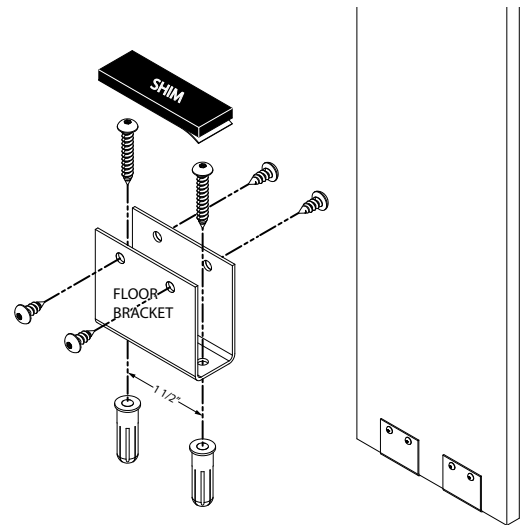
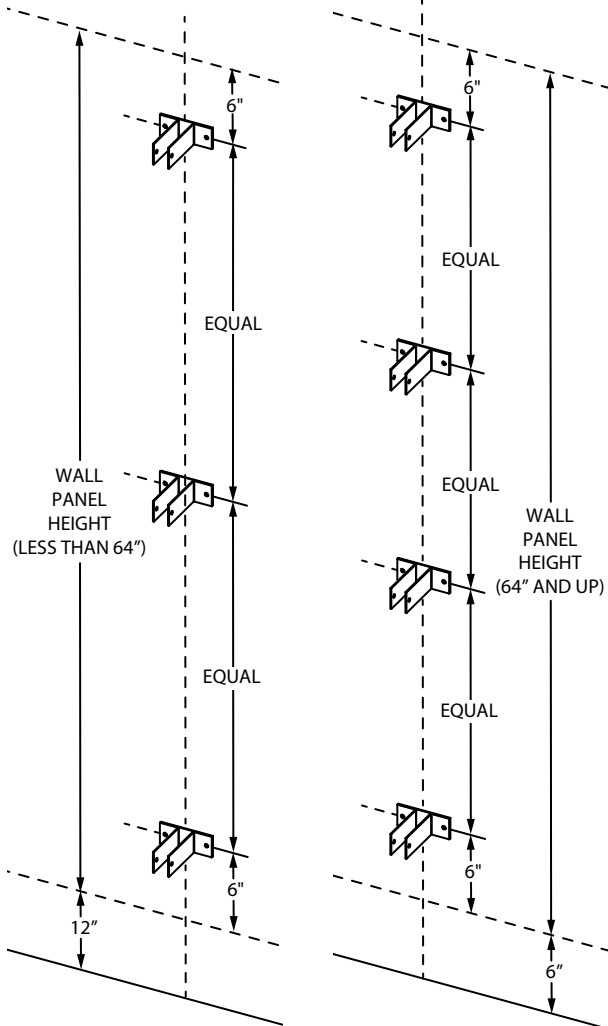

FIG. 2B



# Prism™ Solid Surface Installation Instructions Toilet Partitions

FIG. 3A



### Step 3 - Installing Wall Brackets

1. Use tape measure and level to measure, plumb, and mark center lines of all pilasters and panels on the structural walls.
2. From the highest point of the finished floor, measure up 12" (30.5cm) for wall panels less than 64" high or 6" (15.2cm) for wall panels 64" high and up, and add a mark to the structural wall where the bottom of the wall panel will be located. Then measure up from this mark the height of the wall panel and place a mark on the wall. Transfer these measurements to all other plumb lines in the room.
3. Measure in 6" (15.2cm) from each of the wall panel locating lines and place a mark on the wall at each location. The remaining wall brackets (total of 3 for less than 64", total of 4 for 64" and up) are to be evenly spaced between the top and bottom brackets. Transfer all wall bracket locations to each plumb line. (See Figure 3A). For continuous brackets, center the bracket vertically on the wall panel height.
4. Use the appropriate bracket as a template for marking the locations of all mounting holes (on exposed end panel, position the bracket with the ear facing toward the inside of the stall). (See Figure 3C)
5. Drill a 5/16" (7.9mm) hole (min. 2" [50.8mm] deep) at each location.
6. Insert the plastic anchors in all holes and secure the brackets to the wall with the #14 x 2" pin-in torx screws.

FIG. 3B

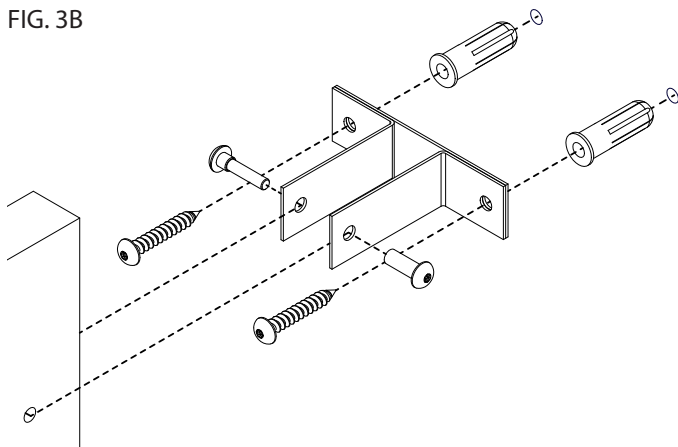
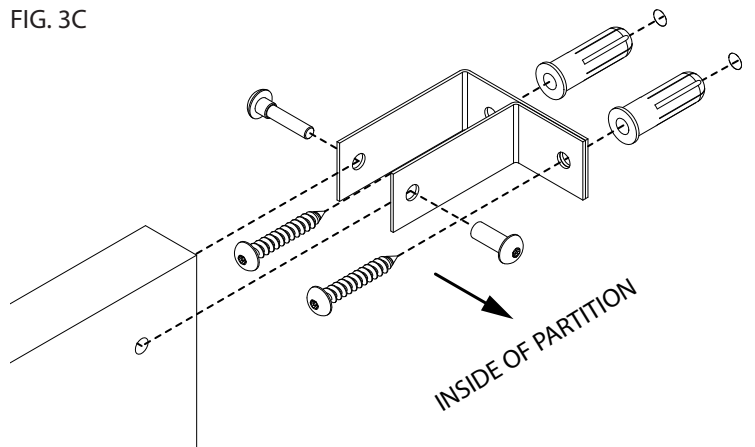

FIG. 3C



# Prism™ Solid Surface Installation Instructions Toilet Partitions

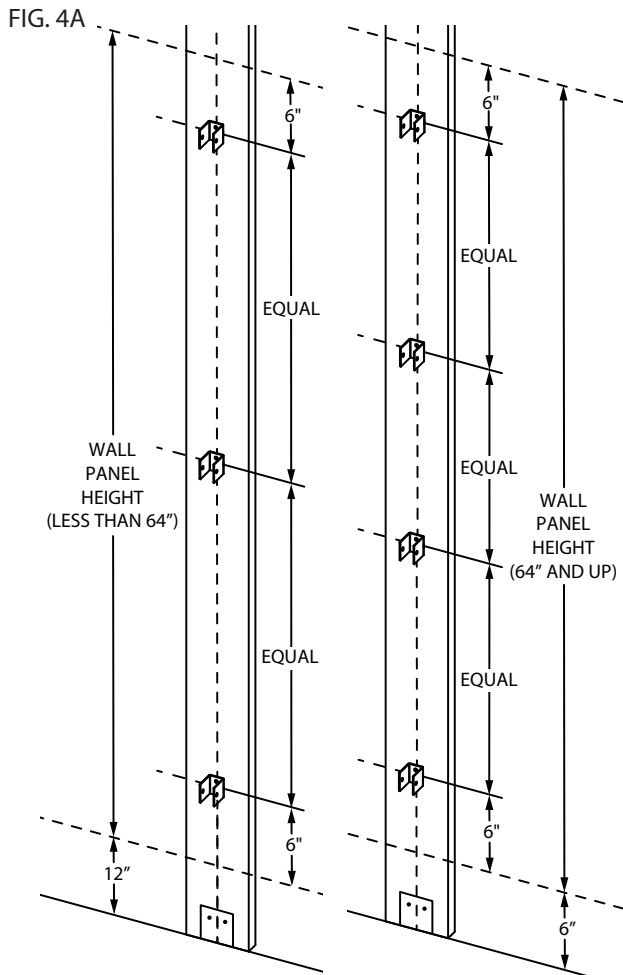
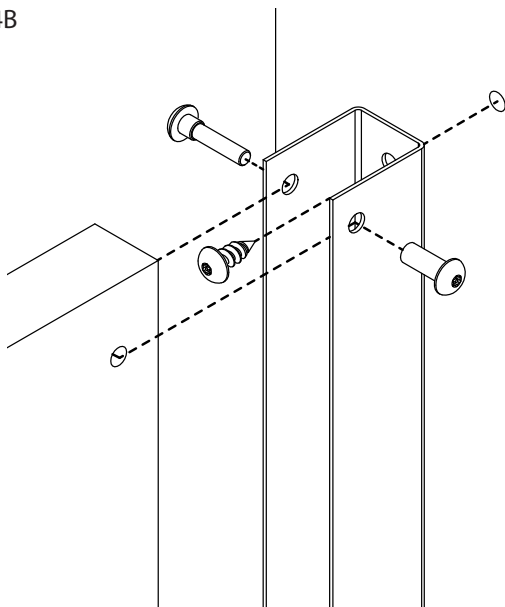

FIG. 4B



## Step 4 - Installing Pilaster "U-style" Brackets (Floor Mounted and Floor to Ceiling Only)

1. From the highest point of the finished floor, measure up 12" (30.5cm) for wall panels less than 64" high or 6" (15.2cm) for wall panels 64" high and up, and add a mark on the panel center line (on pilaster). Then measure up from this mark the height of the wall panel and place a mark on the wall.
2. Measure in 6" (15.2cm) from each of the wall panel locating lines and place a mark on the pilaster at each location. The remaining u-brackets (total of 3 for less than 64"; total of 4 for 64" and up) are to be evenly spaced between the top and bottom brackets. (See Figure 4A).

**Tip:** Refer to layout drawing for offset panel placements. For continuous brackets see #6-9 below.

3. Place center of each bracket on the mark, using the bracket as a template, mark the hole locations on the pilaster.
4. Drill a 15/64" (6.0mm) pilot hole, 1/4" [6.4mm] deep, at each location.
5. Secure the bracket using the #14 x 3/4" pan head screws provided. Skip #6-9 below.
6. For continuous brackets, center the the bracket vertically on the wall panel and mark the bottom edge location of the continuous bracket on the pilaster. **Tip:** Refer to layout drawing for offset panel placements.
7. Place continuous bracket on panel centerline, using the bracket as a template, mark the hole locations on the pilaster.
8. Drill a 15/64" (6.0mm) pilot hole, 1/4" [6.4mm] deep, at each location.
9. Secure the bracket using the #14 x 3/4" pan head screws provided. (See Figure 4B).

# Prism™ Solid Surface Installation Instructions Toilet Partitions

FIG. 5A

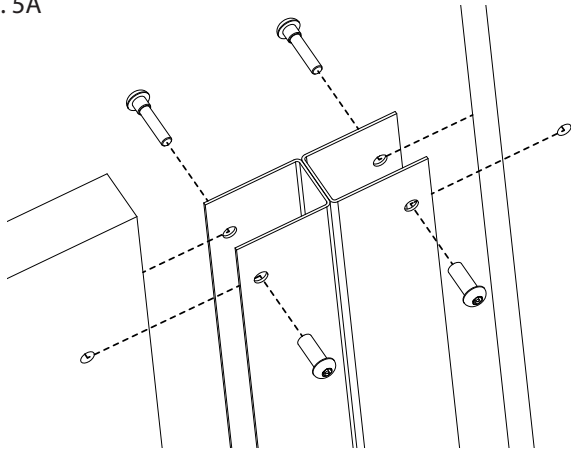

## Installing Inline Panel "H-Style" Brackets

10. Center the the bracket vertically on the wall panel and mark the bottom edge location of the continuous bracket on the pilaster.
11. Place "H-Style" bracket on the pilaster, use the bracket as a template to mark the hole locations on the pilaster.
12. Drill 1/4" (6.4mm) holes through the pilaster, where marked.
13. Secure the bracket using the barrel nuts and shoulder screws provided. (See Figure 5A).

FIG. 5B

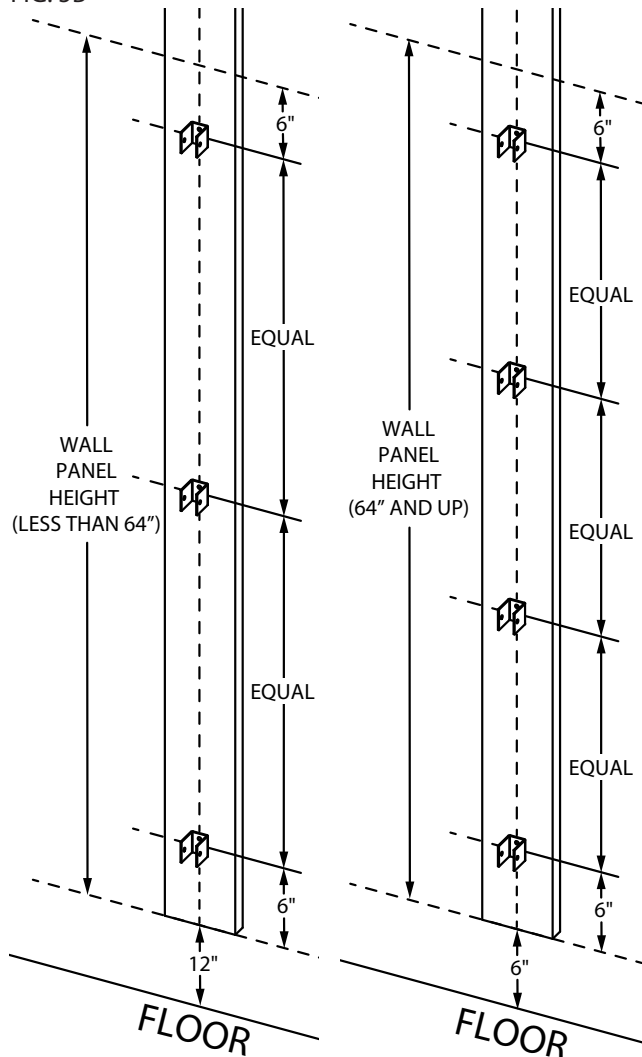

## Installing Pilaster "U-style" Brackets (Ceiling Hung Only)

14. Measure up the wall panel height from the bottom of the pilaster and place a mark on the pilaster at this height. Transfer this measurement to all other pilasters.
15. Measure up 6" (15.2cm) from the bottom of the pilaster and 6" (15.2cm) down from the previous mark and place a mark on the pilaster at each location. The remaining brackets are to be evenly spaced between the outside brackets. Transfer all bracket locations to each pilaster. (See Figure 5B).

**Tip:** Refer to layout drawing for offset panel placements. For continuous brackets see #19-22 below.

16. Place center of each bracket on the mark, using the bracket as a template, mark the hole locations on the pilaster.
17. Drill a 15/64" (6.0mm) pilot hole, 1/4" [6.4mm] deep, at each location.
18. Secure the bracket using the #14 x 3/4" pan head screws provided. Skip #19-22 below.
19. For continuous brackets, center the the bracket vertically on the wall panel and mark the bottom edge location of the continuous bracket on the pilaster. **Tip:** Refer to layout drawing for offset panel placements.
20. Place continuous bracket on panel centerline, using the bracket as a template, mark the hole locations on the pilaster.
21. Drill a 15/64" (6.0mm) pilot hole, 1/4" [6.4mm] deep, at each location.
22. Secure the bracket using the #14 x 3/4" pan head screws provided.

# Prism™ Solid Surface Installation Instructions Toilet Partitions

FIG. 6

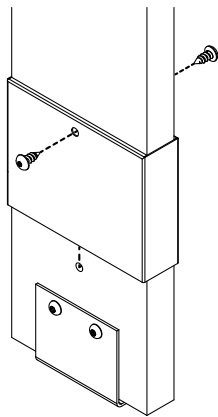
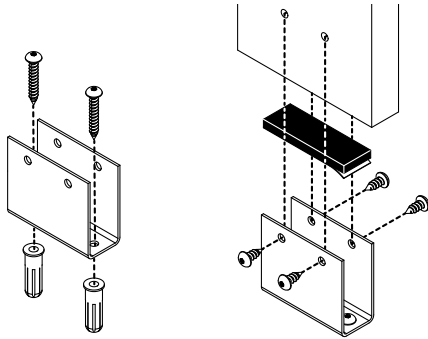
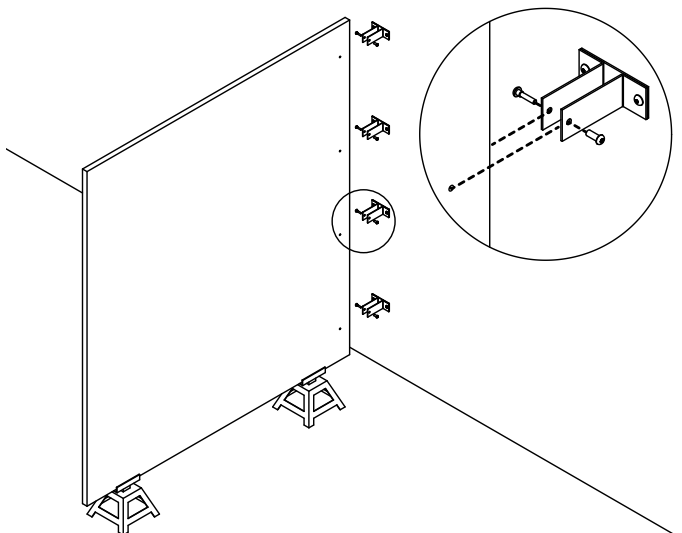

FIG. 7



## Step 5 - Installing Panels and Pilasters (Figures 6 and 7)

**Tip:** Pilasters located at structural walls should be mounted first. Before installing pilasters, slide shoe up from the bottom and temporarily secure with tape. Solid Surface shoes may need to be cut down slightly when pilaster is located by a wall.

Where ceiling mount is required, structure in ceiling is not furnished by InPro® Corporation. Actual mounting system must be designed by the architect or structural engineer and furnished by others. See Installation Instructions – Step Eleven.

Start at one end of the layout and install a wall panel, then a pilaster. Continue this sequence until all wall panels and pilasters are installed. Refer to Layout Drawing and leave the appropriate gaps (standard gap is 1" [25.4mm] between wall panel and structural wall, and ½" [12.7mm] between the wall panel and the pilaster).

Ensure that the pilasters are plumb and level to each other. The pilaster height can be adjusted by applying peel and stick red silicone rubber shims onto top of screw heads to desired height, before the mounting holes are drilled. Shims are ¼" (6.4mm) thick and fit inside the floor bracket, use as necessary.

1. Place a panel onto the appropriate spacers, and insert the panel into the wall brackets.
2. Slide shoe up the pilaster from the bottom and temporarily secure with tape.
3. Peel and stick the necessary number of shims to make level.
4. Set the pilaster onto the floor anchor shim while placing the pilaster bracket around the panel.
5. Confirm all parts are level and plumb.
6. Using brackets as a template, drill ¼" (6.4mm) holes through panels for each bracket hole.
7. Secure the panels to the brackets using the barrel nuts and shoulder screws provided.
8. Slide the pilaster shoe down over the floor bracket and transfer the shoe mounting holes to the pilaster.
9. Slide the shoe back up the pilaster and secure with tape.
10. Drill a 15/64" (6.0mm) pilot hole, ¼" [6.4mm] deep at this location.
11. Slide the shoe down over the floor anchor bracket, and secure with Pan 6-lobe screws. Silicone top perimeter of shoe using color match silicone, if desired.
12. Repeat steps for each partition unit.

# Prism™ Solid Surface Installation Instructions Toilet Partitions

FIG. 8A

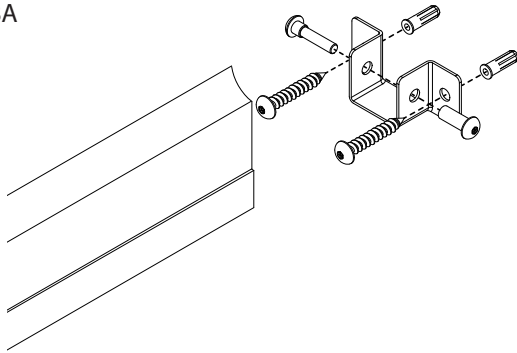

FIG. 8B

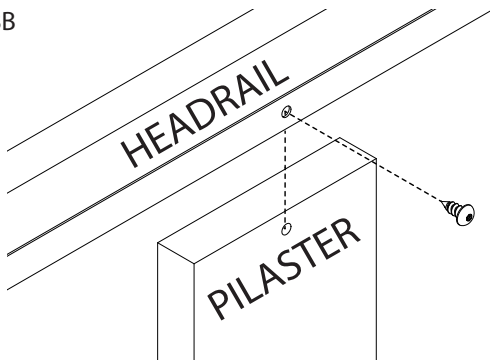

FIG. 9A

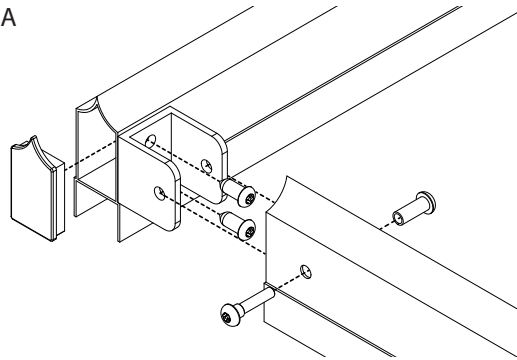
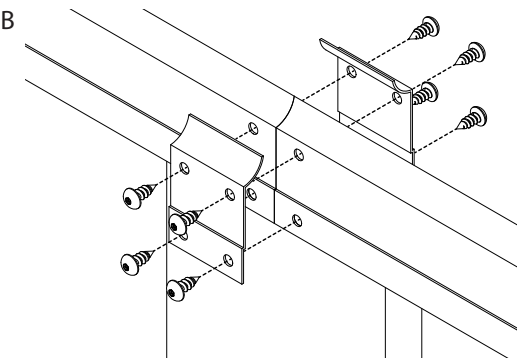

FIG. 9B



## Step 6 - Installing Headrail (*Figures 8 and 9*)

**Tip:** Make sure the pilasters are plumb and that all shoulder bolts and barrel nuts are tight. Leave the appropriate door spacing between pilasters (refer to the Layout Drawings). Some headrail sections may need to be cut to length on site (refer to the Layout Drawings). Head rail sections that need to be joined in-line should meet and be connected over a pilaster support (#8 x 1/2" screws and head rail connector pack provided).

1. Place head rail over the top of each pilaster and slide it tight against the side wall.
2. Position head rail bracket and mark the bracket mounting holes on the wall.
3. Drill 5/16" (7.9mm) hole (min. 2" [5.1cm] deep) at each location.
4. Secure each bracket to the wall with screws and plastic anchors provided.
5. Place head rail back into position and using the head rail bracket as a template, drill a 1/4" (6.4mm) hole through the head rail.
6. Fasten the head rail to the bracket using barrel nuts and screws provided. (*See Figure 8A*)
7. On the inside of each pilaster (starting at one end), drill a 1/4" (6.4mm) hole through one face of the headrail only.
8. Using this hole as a template, drill a 15/64" (5.9mm) pilot hole into the pilaster 1/4" (6.4mm) deep. Secure the headrail to the inside of the pilaster with #14 x 3/4" screws provided.
9. For outside corner layouts, cut both head rails to correct length.
10. Attach the corner pack bracket to the first headrail with the provided screws.
11. Slide the remaining headrail into the corner pack bracket and drill a 1/4" (6.4mm) hole through the headrail at the mounting hole location.
12. Attach the headrail to the bracket with the provided shoulder bolt and barrel nut.
13. Install the headrail end plug into the exposed end of the headrail. (*See Figure 9A*)
14. Attach the other end of the headrail to the wall with a wall bracket as shown above.
15. When two pieces of headrail must be spliced in-line, center the seam over a pilaster.
16. Using the headrail connector plates as a template mark and drill 1/4" (6.4mm) holes through the headrails and 1/4" (6.4mm) deep into the pilaster.
17. Attach the connector plates with the #14 x 5/8" pan head screws provided. (*See Figure 9B*)

# Prism™ Solid Surface Installation Instructions Toilet Partitions

FIG. 10

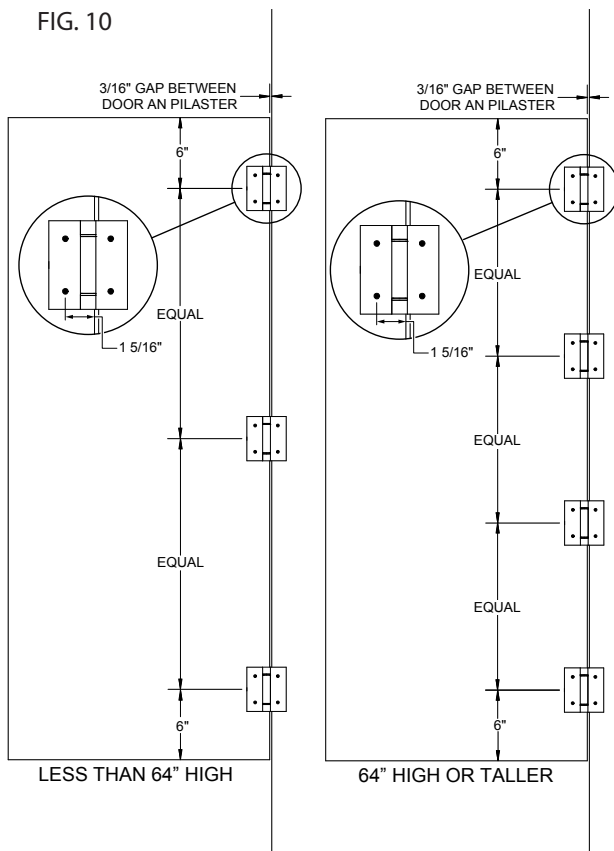

## Step 7 - Installing Surface-Mounted Hinges (Figure 10)

**Tip:** Before installing hinges, make sure the door openings are the correct size, all pilasters are plumb and that the head rail is installed.

Determine the door swing by facing the stall from the outside. Refer to your Layout Drawings to determine each specific door swing. (See Figure 12)

1. Mark the hinge hole locations. (See Figure 10)
2. Drill 15/64" (6.0mm) pilot holes approximately 1/4" (6.4mm) deep at each hole location.
3. Attach the hinges to the door with the #14 x 3/4" Pan 6-lobe screws.
4. Place the door on the same spacer used for the wall panels, and move it into position (when the door is in the closed position, the standard gap at the hinge and latch sides should be 3/16" (4.8 mm) and the bottom of the door should be the same height as the wall panels).
5. Using the hinges as templates, mark and drill 15/64" (6.0mm) pilot holes approximately 1/4" (6.4mm) deep in the pilaster.
6. Secure the hinges to the pilaster with the #14 x 3/4" Pan 6-lobe screws.
7. Adjust the pintle in the top hinge to determine the "at rest" position of the door.

FIG. 11

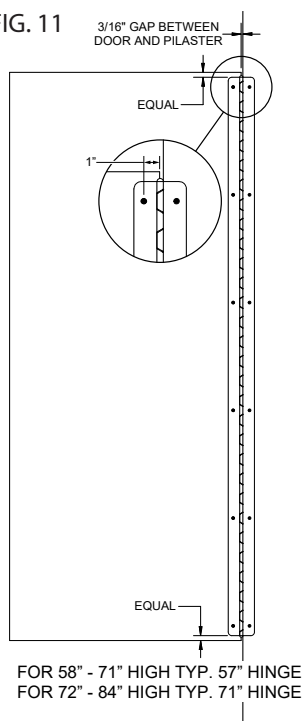

## Step 8 - Attaching Piano Hinge

1. Mark the hinge hole locations. (See Figure 11)
2. Drill 15/64" (6.0mm) pilot holes approximately 1/4" (6.4mm) deep at each hole location.
3. Attach the continuous piano hinge to door with the #14 x 3/4" Pan 6-lobe screws.
4. Place the door on the same spacer used for the wall panels, and move into position (when the door is in the closed position, the standard gap at hinge and latch sides should be 3/16" (4.8mm) and the bottom of the door should be the same height as the wall panels).
5. Using the hinge as a template, mark and drill 15/64" (6.0mm) pilot hole approximately 1/4" (6.4mm) deep in the pilaster.
6. Secure the hinge to the pilaster with the #14 x 3/4" Pan 6-lobe screws.

FIG. 12

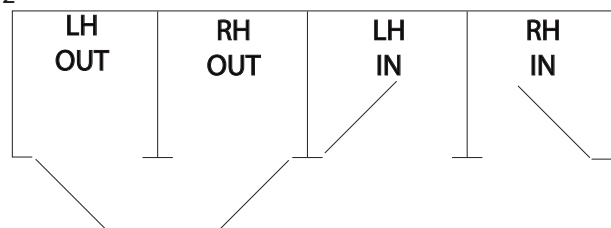



# Prism™ Solid Surface Installation Instructions Toilet Partitions

FIG. 13 - SLIDE LATCH

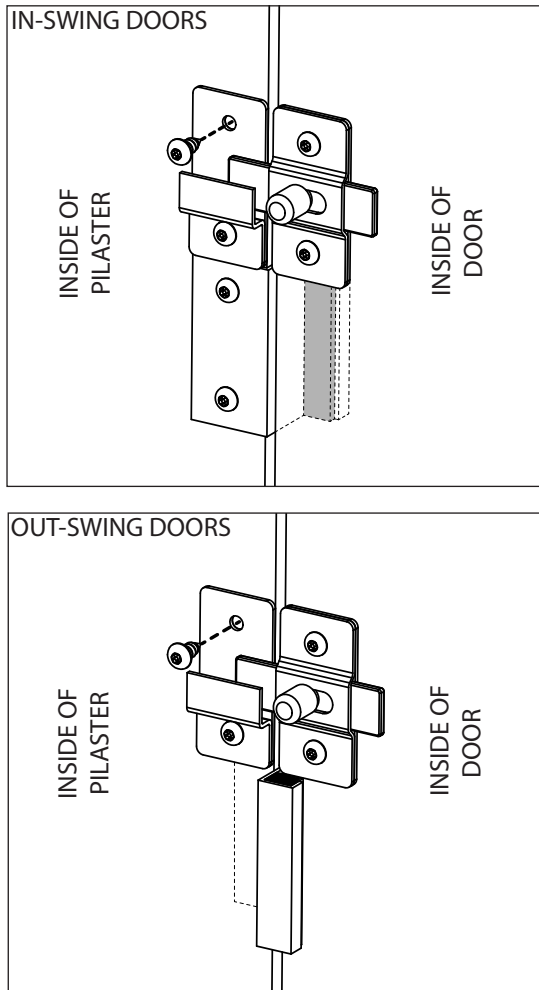

Step 9 - Installing Latch, Strike, and Keeper (*Figures 13 & 14*)

**Tip:** Local codes vary from state to state. Check your local codes before installing the coat hook and door pulls. Consult the ADA Standards for any ADA Compliant Stalls.

**In-Swing:**

1. Position the latch on the inside of the door at the desired location.
2. Using the latch as a template mark the hole locations on the door.
3. Drill a 15/64" (6.0mm) pilot hole approximately 1/4" (6.4mm) deep at each location.
4. Position the latch on the inside of the door, over the pilot holes.
5. Secure the latch to the door with the #14 x 3/4" Pan 6-lobe screws.
6. With the door in the closed position, place the keeper on the inside of the pilaster and align with the latch so th latch fits within the opening of the keeper and operates freely.
7. Using the keeper as a template, mark the hole locations on the pilaster and drill two 15/64" (6.0mm) pilot holes approximately 1/4" (6.4mm) deep.
8. Using the strike as a template, mark the hole locations on the pilaster (The strike plate will be on the inside of the pilaster while the bumper will be on the outside of the door). Drill a 15/64" (6.0mm) pilot hole approximately 1/4" (6.4mm) deep at each location.
9. Secure the strike & keeper to the pilaster with the #14 x 3/4" Pan 6-lobe screws.

**Out-Swing:**

- The instructions are the same as for an In-Swing except that the strike plate will be on the outside of the pilaster and the bumper will be on the inside of the door.

FIG. 14 - THROW LATCH

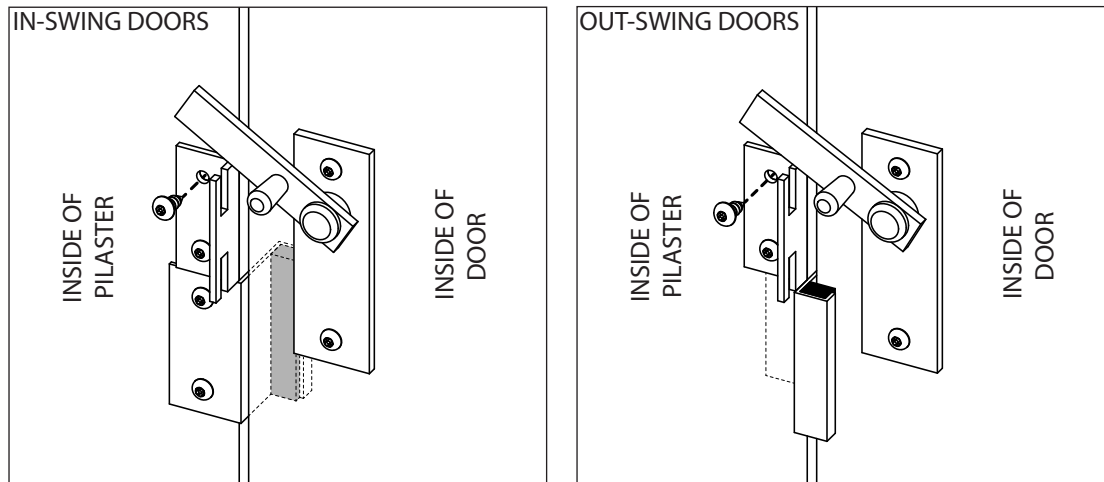

# Prism™ Solid Surface Installation Instructions Toilet Partitions

FIG. 15

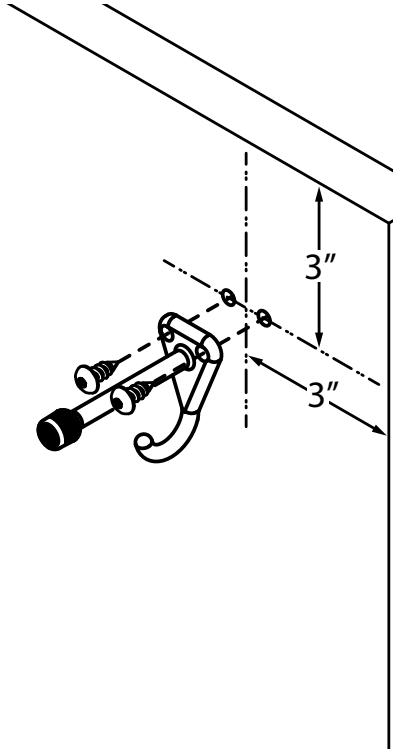

## Step 10 - Installing Door Pulls and Coat Hooks

**Tip:** Local codes vary from state to state. Check your local codes before installing the coat hook and door pulls. Consult the ADA Standards for any ADA Compliant Stalls.

### Coat Hook: (Figures 15)

1. On the inside (latch side) of the door measure down 3" (76.2mm) and place a mark on the door, measure over 3" (76.2mm) from the edge of the door and make a mark.
2. Center the coat hook on the marks created in the previous step. Using the coat hook as a template mark the mounting holes on the door.
3. Drill 15/64" (6.0mm) pilot holes approximately 1/4" (6.4mm) deep at each location.
4. Secure the coat hook to the door with #14 x 3/4" Pan 6-lobe screws.

### Door Pull: (Figures 16) Only provided for outswing doors unless noted.

1. Place the door pull in the desired location on the inside (latch side) of the door and place a mark on the door for the top hole. Measure down 3 1/2" (88.9mm) and place a mark for the second hole.
2. Drill 1/4" (6.4mm) holes through the door at the each location.
3. Secure the door pull, to the door, by inserting the screws through the inside handle and door. Then thread them into the outside handle and tighten.

FIG. 16

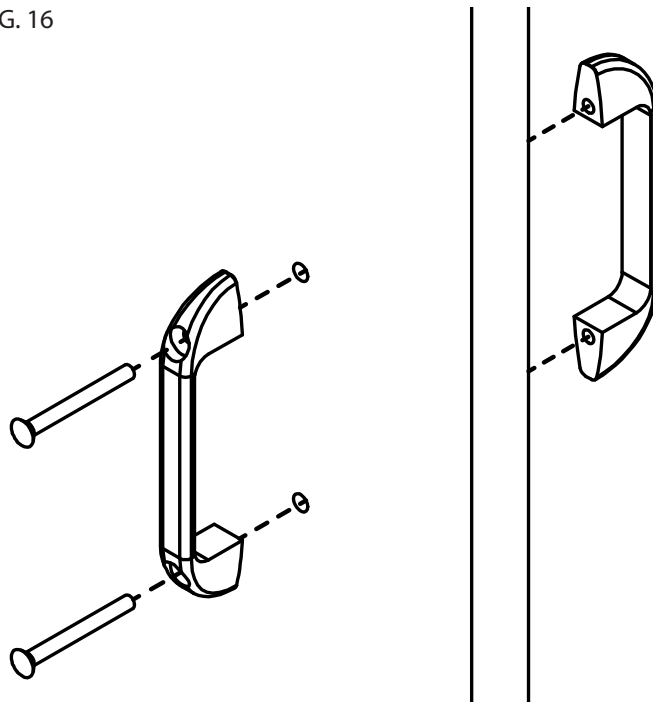

# Prism™ Solid Surface Installation Instructions Toilet Partitions

## FLOOR TO CEILING AND CEILING MOUNTED PARTITIONS

FIG. 17A

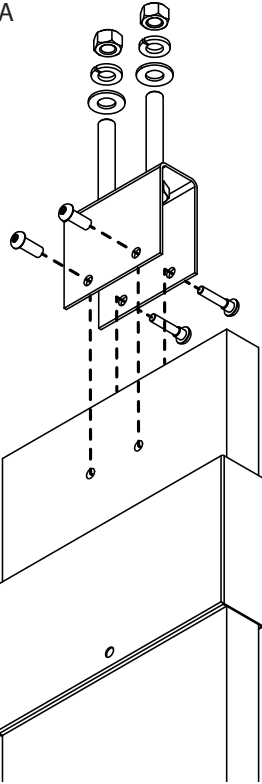
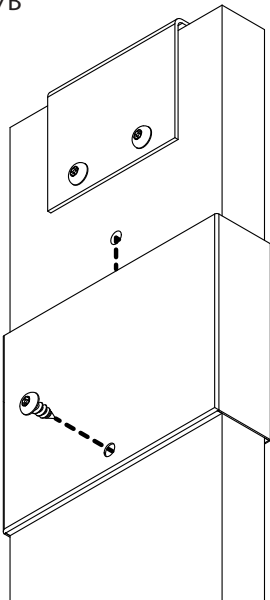

FIG. 17B



### Step 11 - Installing Floor to Ceiling and Ceiling Mounted Pilasters

Where ceiling mount is required, steel structure in ceiling is not furnished by InPro® Corporation. Actual mounting system must be designed by the architect or structural engineer, and furnished by others.

Ceiling anchors are to be installed before finished ceiling is applied if working with a finished ceiling.

**Tip:** There will be two "Ceiling Anchors" for pilasters 8" and larger, the brackets should be evenly spaced.

1. Drill 7/16" (11mm) holes through structural steel where mounting brackets are required.
2. Install flat washer, lock washer and hex nut. Tighten hex nut to secure. *(See Figure 17A)*
3. Slide shoe down the pilaster from the top and temporarily secure with tape.
4. Insert pilaster into ceiling anchor and adjust to desired height so all pilasters are plumb and level to each other.
5. Using the brackets as a template, drill 1/4" (6.4mm) holes through pilasters at each bracket hole location.
6. Secure the pilasters to the brackets using the barrel nuts and shoulder bolts provided. *(See Figure 17A)*
7. Slide the shoe up over the ceiling anchor bracket and mark mounting hole location.
8. Drill a 15/64" (6.0mm) pilot holes approximately 1/4" (6.4mm) deep at this location. *(See Figure 17B)*
9. Secure with the a #14 x 3/4" Pan 6-lobe screw.
10. Repeat steps for each partition unit.

# Prism™ Solid Surface Installation Instructions Toilet Partitions

## CEILING MOUNTED PARTITIONS - LATERAL BRACE

FIG. 18

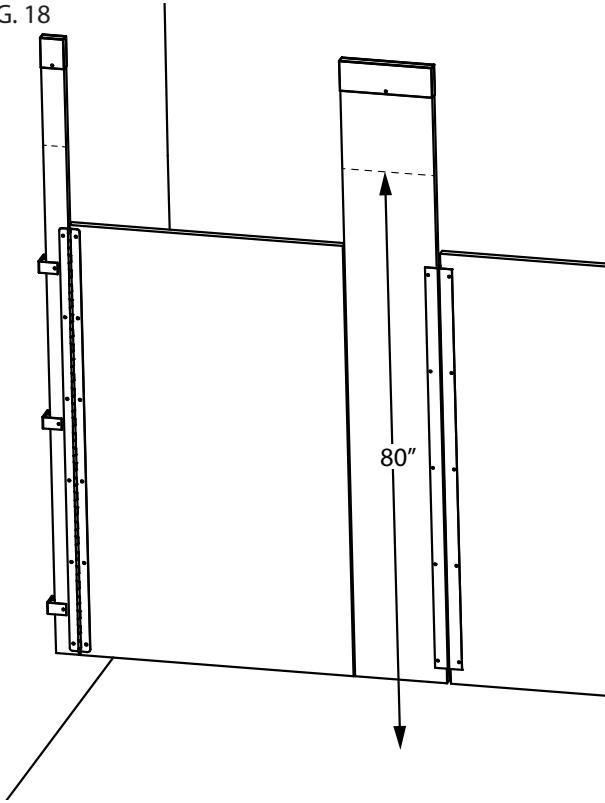

### Step 12 - Installing Pilaster Lateral Brace

1. Mark a level line, at least 80" (203.2cm) above the finish floor, on the backside of every Pilaster. (See Figure 18)
2. Cut lateral brace to required length with a typical fit for a wall-to-wall placement. Plan to place this cut against a wall during installation.
3. Measure the location of every pilaster from a fixed point or wall.
4. Transfer those measurements, identifying the vertical edges of the pilasters, to the lateral brace. Mark with a pencil.
5. After identifying pilaster locations on the lateral brace, mark two pilot holes centered on each pilaster. The pilot holes should be 1 1/2" from the top and bottom edges of the lateral brace.
6. Using a 1/4" (6.4mm) drill bit, drill pilot holes completely through lateral brace. Confirm vertical alignment.
7. Position lateral brace on pilasters, above the line marked in step 1, and make sure pilot holes are centered on the pilasters.
8. Transfer pilot holes from the lateral brace to the pilasters.
9. Drill 1/4" (6.4mm) through holes at each location.
10. Secure the lateral brace to the pilasters with the provided barrel nuts and shoulder bolts. (See Figure 19)

FIG. 19

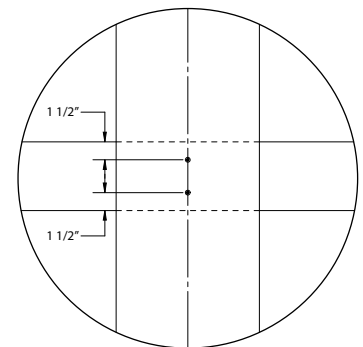
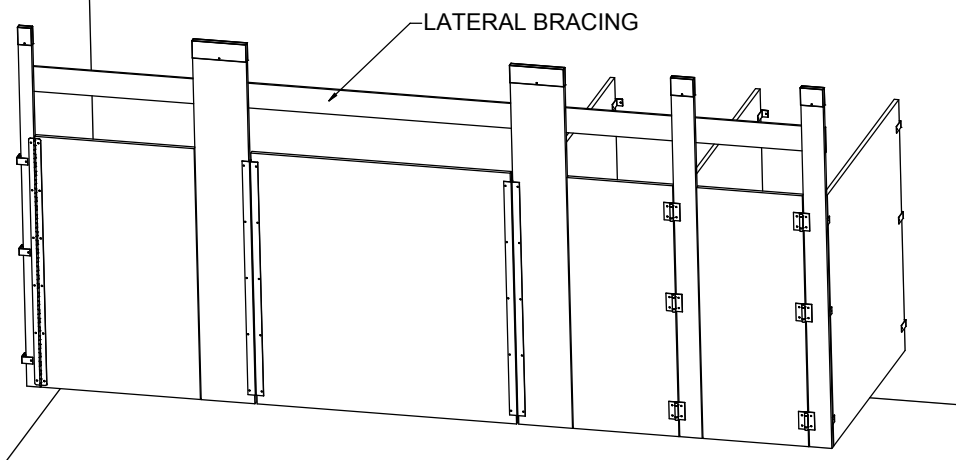

TYPICAL LATERAL BRACE BOLT HOLE PATTERN

# Prism™ Solid Surface Installation Instructions Toilet Partitions

## PARTITION HARDWARE - Standard Package Brackets

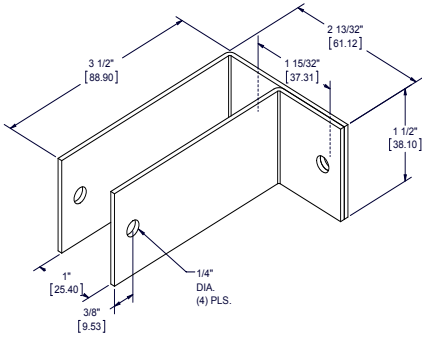

WALL BRACKET, ONE EAR  
DSPPH601279

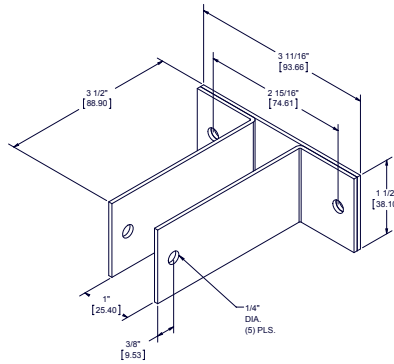

WALL BRACKET, TWO EAR  
DSPPH601269

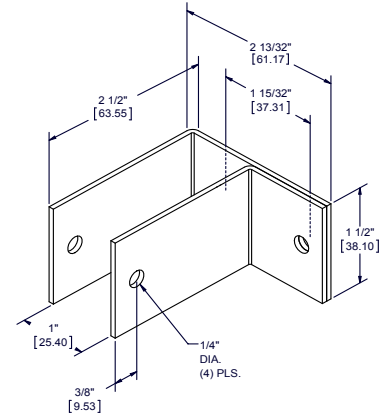

WALL BRACKET, ONE EAR  
DSPPH601769

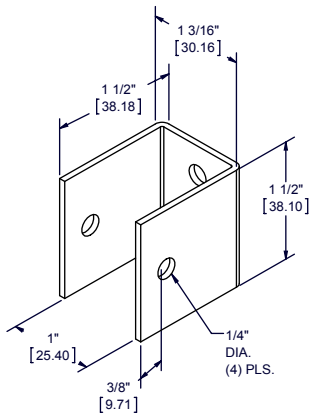

U-BRACKET  
DSPPH192339

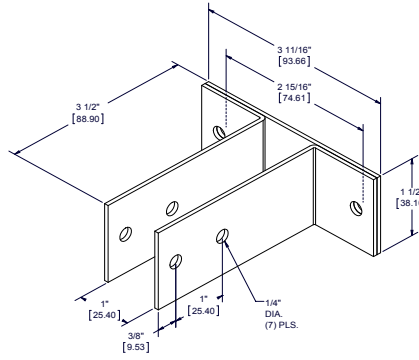

URINAL SCREEN BRACKET  
DSPPH601289

## PARTITION HARDWARE - Standard and Continuous Package Brackets

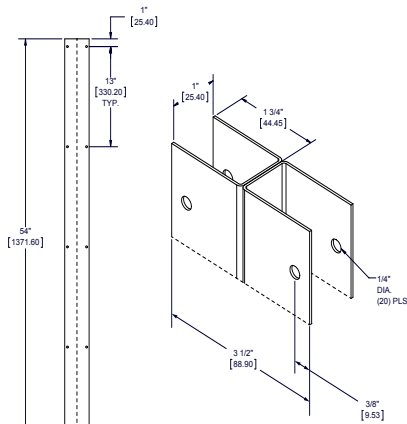

H-BRACKET, 54"  
DSPPH602859

ENDURANT® Washroom Systems

inpro.com • 800.222.5556 • 262.679.9010

World Headquarters S80 W18766 Apollo Drive, Muskego, WI 53150 USA

Installation Hotline: 866.394.6776

**inpro**®

# Prism™ Solid Surface Installation Instructions Toilet Partitions

## PARTITION HARDWARE - Continuous Package Brackets

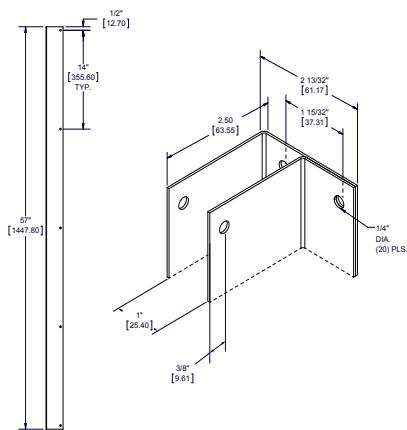

WALL BRACKET, ONE EAR, 57"  
DSPPH602339

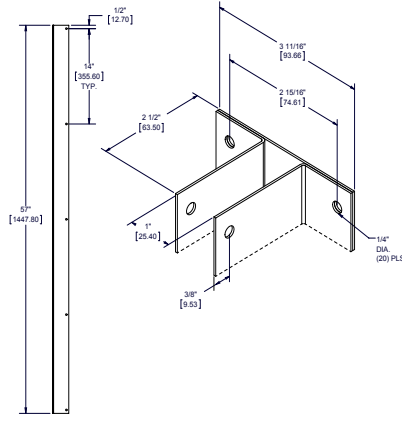

WALL BRACKET, TWO EAR, 57"  
DSPPH602349

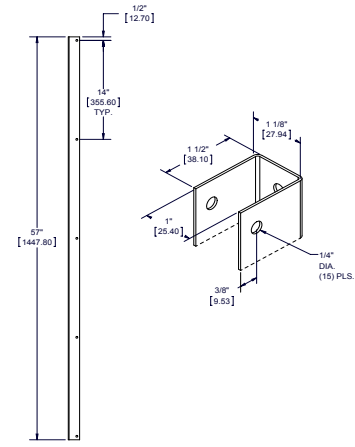

U-BRACKET, 57"  
DSPPH192359

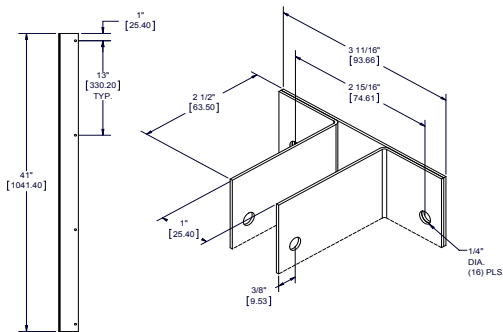

URINAL SCREEN BRACKET, 41"  
DSPPH602609

### LATERAL BRACE HARDWARE KIT (T-27 Pin-in Torx Typical)

- DSPPH188019**
- 1/4" FENDER WASHERS
- 1 5/16" SHOULDER BOLTS
- 5/8" BARREL NUTS

## PARTITION HARDWARE - Typical Fasteners (T-27 Pin-in Torx Typical)

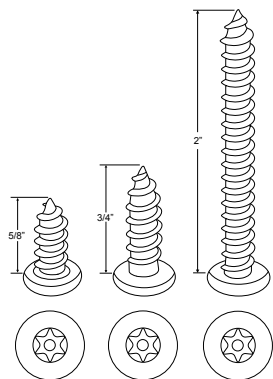

#14 SCREWS  
5/8" - DSPPH250092199  
3/4" - DSPPH250090929  
2" - DSPPH250092389

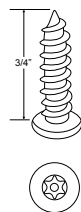

#10 SCREWS  
3/4" - DSPPH250090949

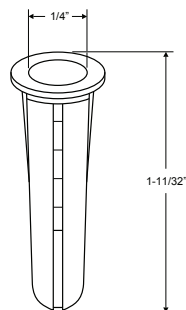

1/4" CONICAL ANCHOR  
DSPPH250009015

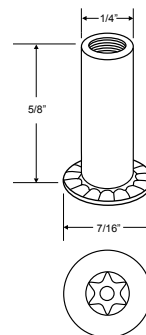

BARREL NUT  
DSPPH250088219

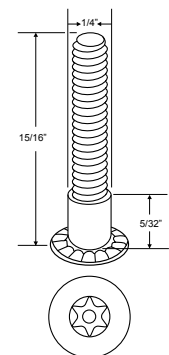

SHOULDER BOLT, 15/16"  
DSPPH25008259



# Prism™ Solid Surface Installation Instructions Toilet Partitions

## PARTITION HARDWARE - Anchors, Bracing and Shoes

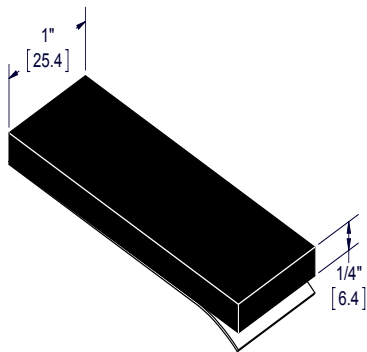

RUBBER SHIM,  
ADHESIVE BACKED  
DSPPHW2614T85

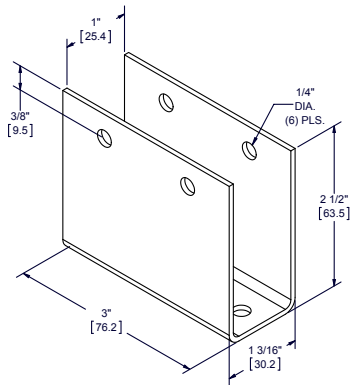

FLOOR BRACKET  
DSPPH192349

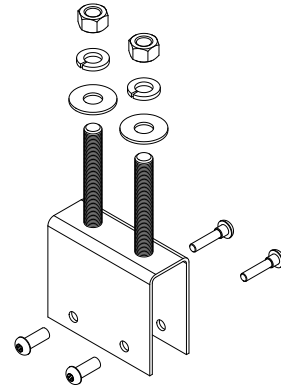

ANCHOR PACK  
DSPPH192279

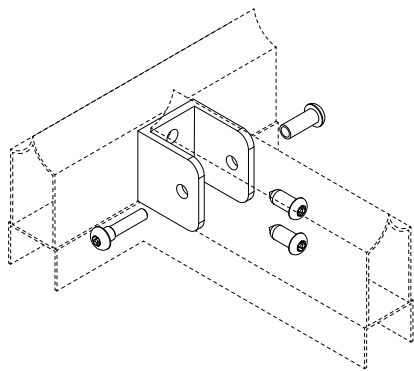

CORNER PACK,  
OVERHEAD BRACING  
DSPPH615803

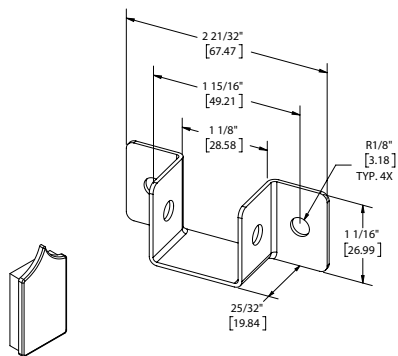

HEADRAIL WALL BRACKET  
DSPPH602169

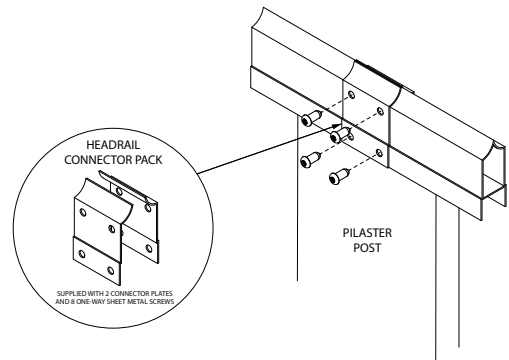

HEADRAIL CONNECTOR PACKS  
DSPPH192282

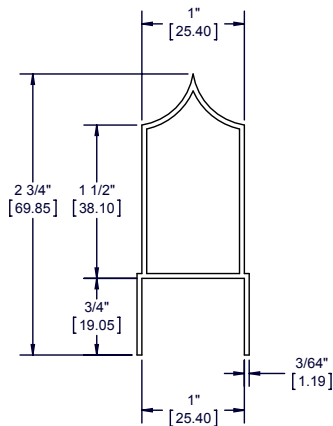

HEADRAILS  
DSPPH192432, DSPPH192452

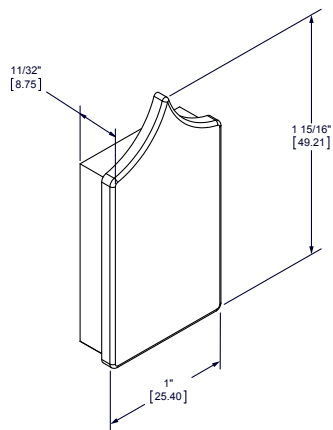

END PLUG, OVERHEAD BRACING  
DSPPHW6675

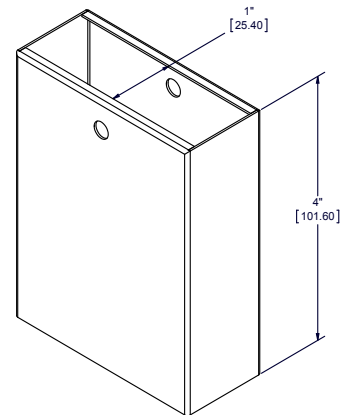

PILASTER SHOE  
WIDTH WILL VARY BASED ON PILASTER WIDTH  
DSPPH193XX9

ENDURANT® Washroom Systems

inpro.com • 800.222.5556 • 262.679.9010

World Headquarters S80 W18766 Apollo Drive, Muskego, WI 53150 USA

Installation Hotline: 866.394.6776

**inpro**®