

Installation Instructions

Stainless Steel Cove Base

Please read all instructions before installing cove base

Important

1. Acclimate materials 24 hrs. before installation. Maintain temperature controlled environment after installation.
2. Install in accordance with manufacturer's installation instructions. Failure to do so will void the warranty.

Installation Tips

1. Use a carbide toothed compound miter saw blade or angle grinder with stainless steel cutting disc when cutting stainless base components.
2. Lubricate blades when cutting to reduce burrs.
3. Clean all cuts using a file or de-burring tool.

Cove Base - Section

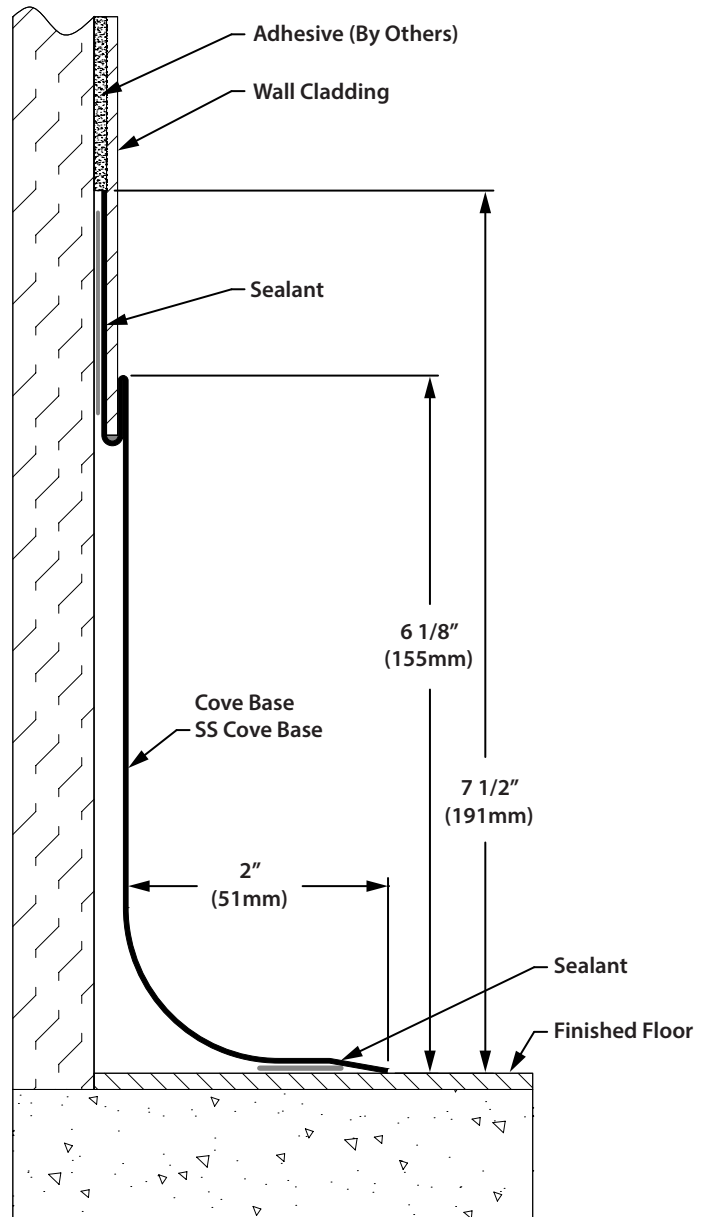

Recommended Tools:

Safety glasses, gloves, tape measure, high adhesion duck tape, square, chalk line, laser level, 10' straight edge, caulk gun, angle grinder with stainless cut off wheels, deburring flap disc, deburring tool and a set of metal files for stainless steel, solvent, cloth rags.

IPC.3231/REV.3

IPC® Door + Wall Protection

inpro.com • 800.222.5556 • 262.679.9010

World Headquarters S80 W18766 Apollo Drive, Muskego, WI 53150 USA

Installation Hotline: 866.394.6776

inpro®

Installation Instructions

Please read all instructions
before installing cove base

Stainless Steel Cove Base

Standard
Hygienic
Cove Base
Components

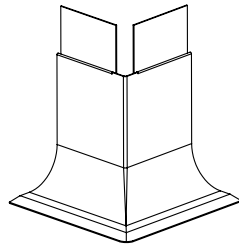
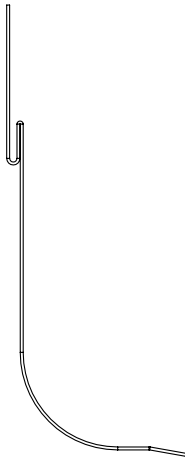

Outside
Corner
(90° & 135°)

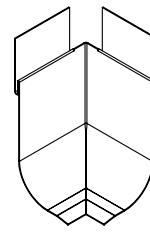

Inside
Corner



End
Cap



Splice

Prism
Hygienic
Cove Base
Components

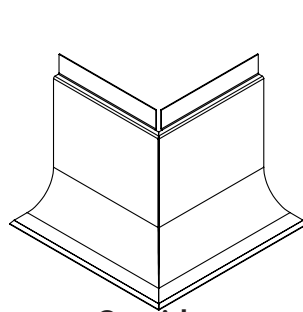
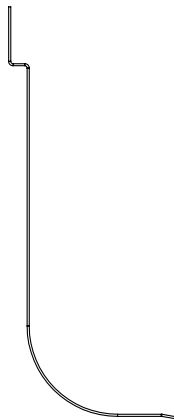

Outside
Corner
(90° & 135°)

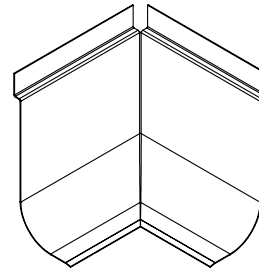

Inside
Corner

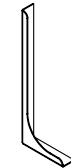

End
Cap



Splice

Long Toe Base
Components

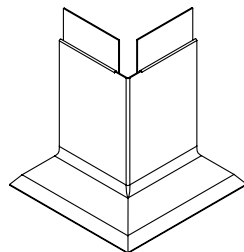
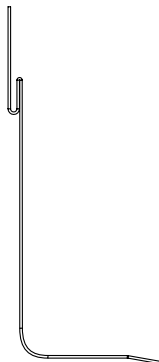

Outside
Corner
(90° & 135°)

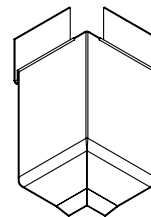

Inside
Corner

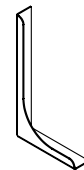

End
Cap



Splice

IPC® Door + Wall Protection

inpro.com • 800.222.5556 • 262.679.9010

World Headquarters S80 W18766 Apollo Drive, Muskego, WI 53150 USA

Installation Hotline: 866.394.6776

inpro®

Installation Instructions

Please read all instructions
before installing cove base

Stainless Steel Cove Base

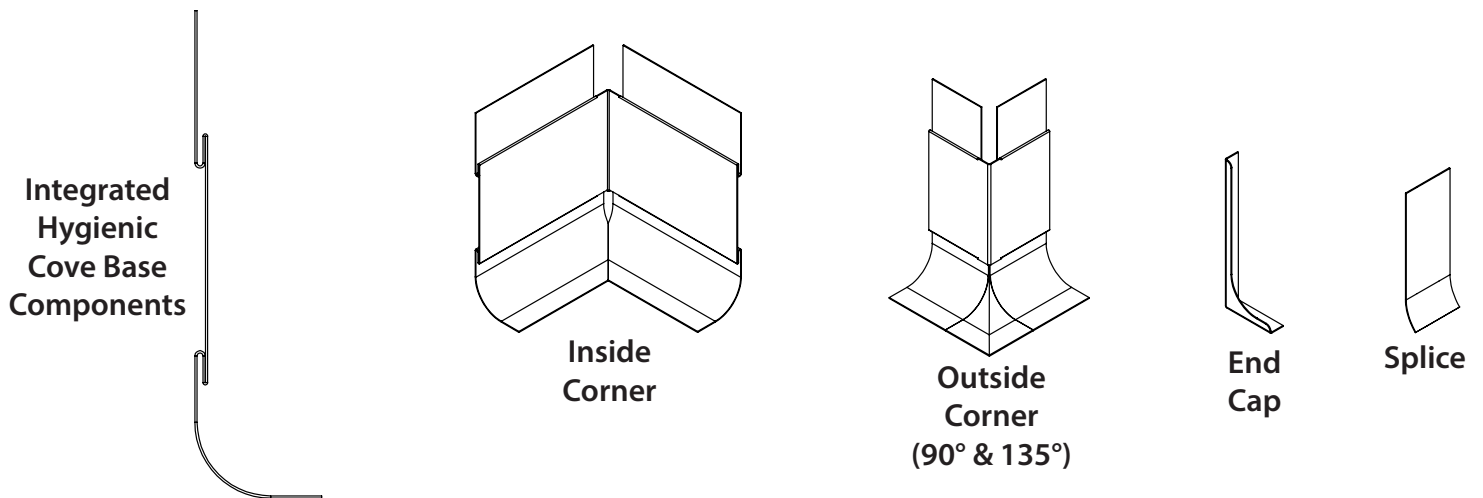
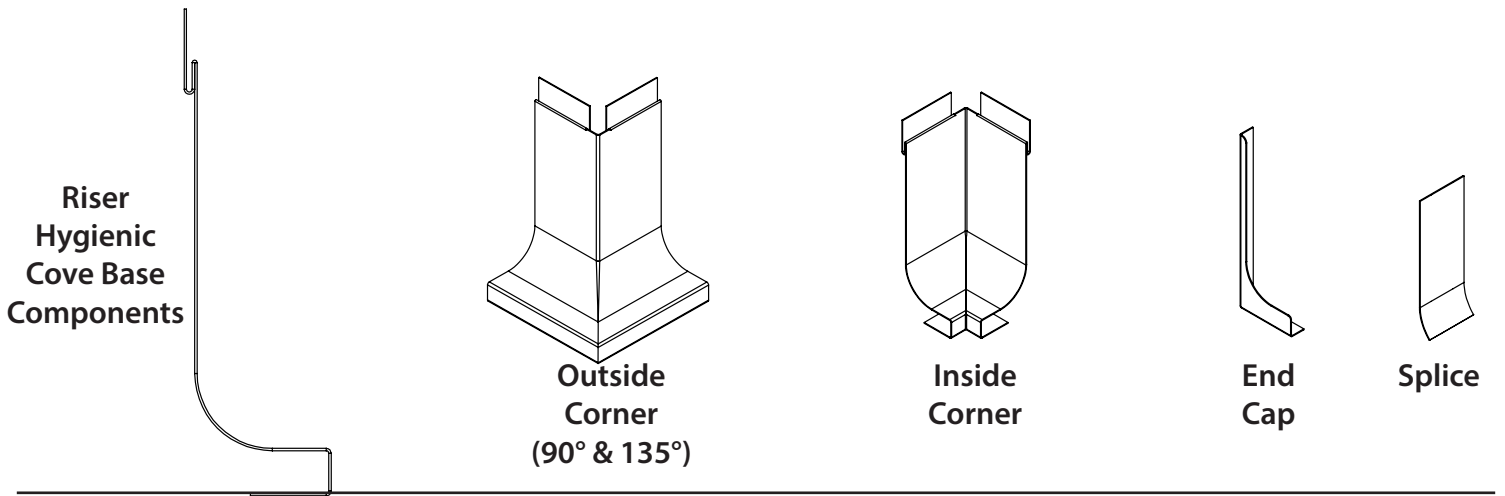

IPC® Door + Wall Protection

inpro.com • 800.222.5556 • 262.679.9010

World Headquarters S80 W18766 Apollo Drive, Muskego, WI 53150 USA

Installation Hotline: 866.394.6776

inpro®

Installation Instructions

Stainless Steel Cove Base

Please read all instructions
before installing cove base

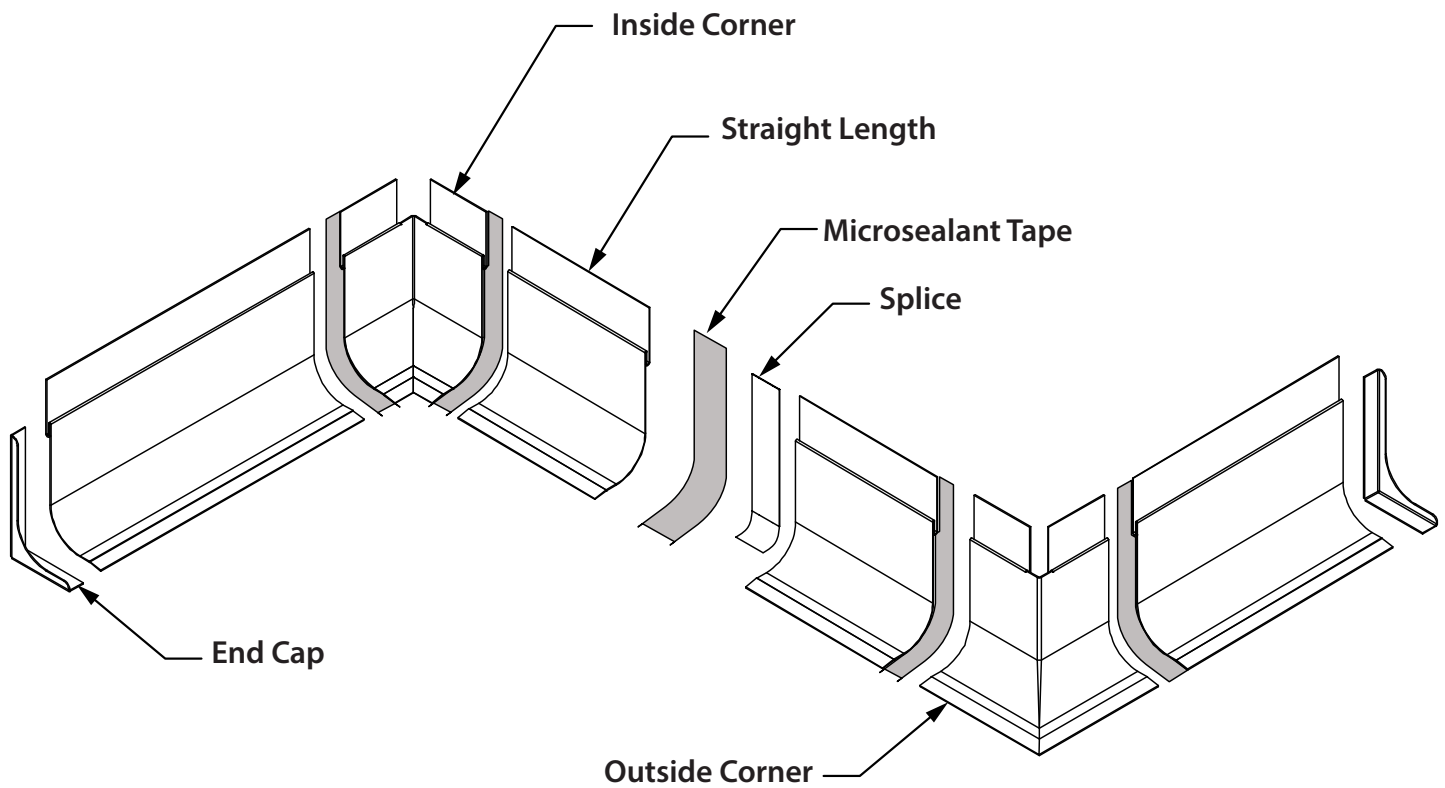

IPC® Door + Wall Protection

inpro.com • 800.222.5556 • 262.679.9010

World Headquarters S80 W18766 Apollo Drive, Muskego, WI 53150 USA

Installation Hotline: 866.394.6776

inpro®

Installation Instructions

Please read all instructions
before installing cove base

Stainless Steel Cove Base

PRE-INSTALLATION

- Before installation, the installer must determine that the environment of the job site meets or exceeds all requirements specified in the installation guide. Installation typically begins when the majority of the job site has been completed. Installing should not start until the building is enclosed (windows and doors), permanent heating and cooling equipment is in operation, and residual moisture from plaster, concrete or terazzo work has dissipated
- Do not begin installation until environment meets or exceeds requirements for installation.

CLEANING / PRE-CONDITIONING

- Prior to installing Cove Base and related components, all surfaces must be clean, structurally sound and free of loose particles.
- Also check for any paint, solvent, grease, sealers and drywall residue that would inhibit proper installation of the Cove Base components. If necessary, do an adhesion test in a non-conspicuous area.
- Floors must be clean and level per industry standard. Deviations greater than 1/8" per 10' are deemed unacceptable and will not be permitted. Corrections to an un-level floor can be made by floating or grinding concrete into the proper tolerances.

WALL PREPARATION

All walls must be free from dirt, grease, and loose paint. Remove any coatings designed to improve clean-up as they may affect adhesion. Sanding or priming of glassy surfaces may be needed to help promote adhesion.

- **NEW DRYWALL OR PLASTER** - Walls must be smooth and wiped clean to remove dust. Seal or prime walls with paint or primer. Allow appropriate time to dry in accordance with the manufacturers application instructions.
- **PAINTED DRYWALL OR PLASTER** - Test painted walls for adhesion by applying an aggressive sticky tape, such as duct tape. Press tape down firmly on painted surface while keeping one end up. Rip tape up quickly. If paint comes up with tape, the paint is not well bonded and wall needs to be stripped and resealed with a recommended paint/ primer. Be sure to test several areas of the wall to insure the entire surface is suitable for installation.
- **CONCRETE AND CONCRETE MASONRY UNITS** - Fill surface of concrete walls with an appropriate filler to make it smooth. Seal or prime walls with paint or primer. Allow paint/ primer to dry in accordance with the manufacturers application instructions.
- **UNEVEN SURFACES**- Adhesion be unsuccessful if installing over uneven surfaces because of the formation of air pockets behind the panel. High and low spots should be leveled to provide an even wall surface.

The following wall conditions require additional preparation or installation techniques:

- **PLYWOOD** - Plywood walls must be flat and even. Warped plywood should be removed and replaced. Solvent-free adhesive cannot be used on any installation over pressure treated or fire-rated plywood.
- **CONCRETE BLOCK AND BRICK** - Concrete block and brick surfaces are naturally uneven, and stainless steel panels installed directly to these surfaces will likely develop loose spots, bulges, and buckles. If a smooth buckle-free wall surface is required, the wall should be furred out, level, and plumb with wood or metal studs or channels and covered with drywall, plywood, factory laminated panels, or other appropriate substrate according to the standard installation instructions.
- **NON-POROUS SURFACES** (ceramic tile, glazed block, moisture resistance substrates, and metal panels) - Does not provide a good surface for adhesive bonding. General-purpose latex-based adhesives will not dry properly on a non-porous surface. Contact an adhesive manufacturer for recommendations in these environments.
- **DIRECT SUNLIGHT** - Prolonged direct sunlight on stainless may cause rapid expansion depending upon amount of heat buildup. Use caution in these areas.
- **HIGH HUMIDITY ROOMS OR LOW TEMP ROOMS** - Carefully follow the guidelines for expansion/contraction for spacing and sealing. Failure to seal moisture entry points with recommended sealant can cause swelling of the substrate that may result in warping, curling, delamination, or bond line separation. Use an adhesive that is recommended for the appropriate conditions. A vapor barrier may be required. Follow the architect or owner's specifications or check your local building codes for specific requirements.

IPC® Door + Wall Protection

inpro.com • 800.222.5556 • 262.679.9010

World Headquarters S80 W18766 Apollo Drive, Muskego, WI 53150 USA

Installation Hotline: 866.394.6776

inpro®

Installation Instructions

Please read all instructions
before installing cove base

Stainless Steel Cove Base

Expansion of Stainless Steel		
Coefficient of Thermal Expansion - μ in. / in $^{\circ}$ C	Expected Expansion of a 120 inch sheet (in)	Expected Expansion of a 3 meter sheet (mm)
16.5	0.08	2.03

PRE-INSTALLATION PLANNING

- Lay out all of the pieces as a sequenced puzzle to dry fit the entire run/room.
- Insure all joints are "hairline" in nature (adjust if needed by using a file, grinder or sander).
- Pre-fit scribe each component before fastening and/or adhering into place.
- All cutting and drilling should be done prior to the application of the adhesive.
- Preplan intersecting points, joints or surfaces that will have Cove Base applied to eliminate any interference with other moldings and/or wall fixtures.
- Pre-drill a countersink hole using a drill bit 3/32" larger that the fastener required.

INSTALLATION

1. Establish a true and level line on the wall appropriate to the back height of the Cove Base system you are installing.
2. Mark and/or snap a line at the intended height.
3. Locate and mark a series of points to indicate the leading edge of the Cove Base system on the floor.
4. Using a pencil or permanent marker, continue with a straight edge to complete the line. ***DO NOT USE A CHALK LINE***
5. Using a pencil or permanent marker, mark the location(s) of the adhesive per each Cove Base requirements.

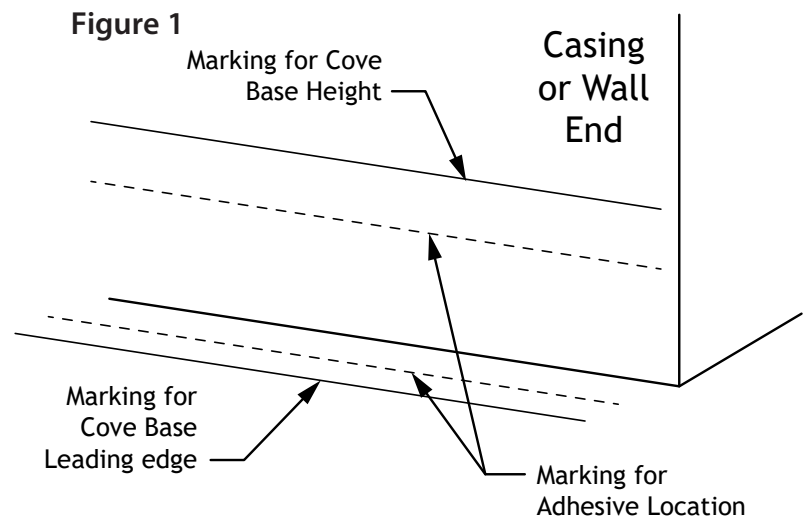

Installation Instructions

Please read all instructions
before installing cove base

Stainless Steel Cove Base

INSTALLATION CONT...

6. Apply micro sealant interconnection at each joint (one per joint). Run microsealant tape from bottom tip to the underside of hem. Allow for a 50% overlap. Press firmly to the back and bottom of the Cove Base.
7. Attach adjoining piece, pressing firmly to the back and bottom of the Cove Base.
8. Only attach as many pieces in a run that can be properly installed by 1-2 people in a 10 minute time frame. Note: A run is typically from a corner condition to an another corner condition.
9. Apply adhesive to the substrate per manufacturer's recommendations. Do NOT apply any more adhesive than can be installed/embedded in the time allowed. Adhesive open time is 10 minutes.
10. Embed "run" vertically in the sealant, do not slide horizontally.
 - a) Align Cove Base to the top of the marks on the wall and secure with tape or rivets.
 - b) Align the front edge of Cove Base with the line on the floor and secure with tape.
11. After completing a run, seal all seams with manufacturer recommended metallic color matched silicone caulk, on the exposed face..
12. Immediately clean up excess sealant with mineral spirits and a clean rag. Dispose of properly.

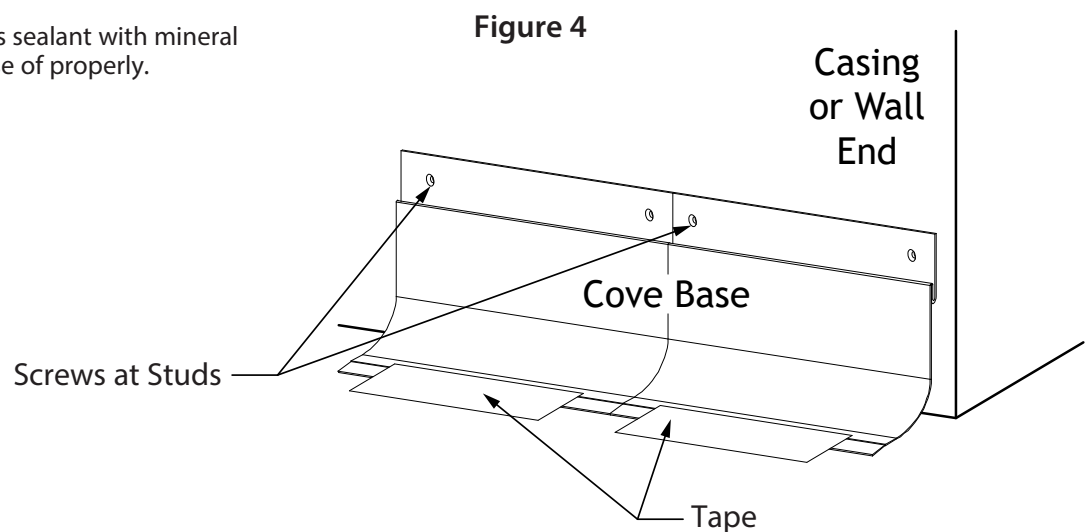
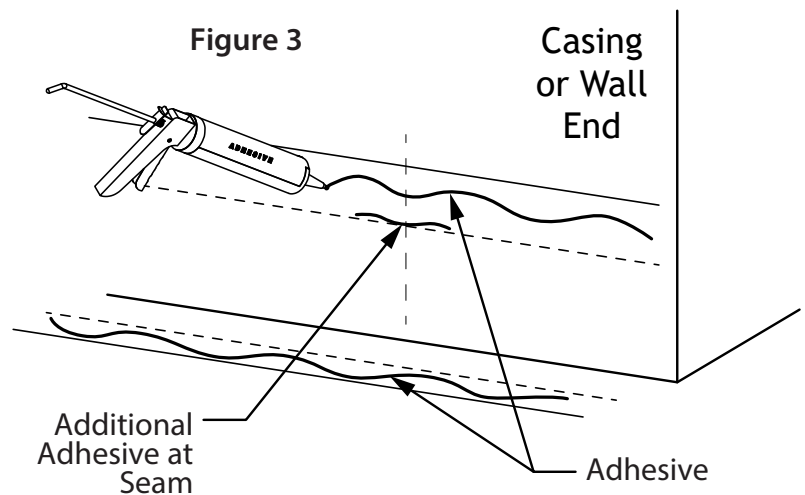
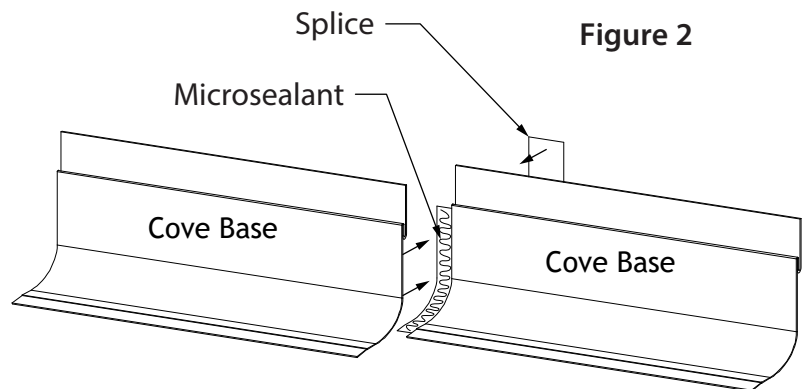

IPC® Door + Wall Protection

inpro.com • 800.222.5556 • 262.679.9010

World Headquarters S80 W18766 Apollo Drive, Muskego, WI 53150 USA

Installation Hotline: 866.394.6776

inpro®